

# BLADE III ES50X

#1 BY DESIGN



**Instruction Manual**  
**Bedienungsanleitung**  
**Manuel d'utilisation**  
**Manuale di Istruzioni**

SPEKTRUM™ DSMX® CONTROL + BEASTX™ FLYBARLESS TECHNOLOGY



## NOTICE

All instructions, warranties and other collateral documents are subject to change at the sole discretion of Horizon Hobby, Inc. For up-to-date product literature, visit [horizonhobby.com](http://horizonhobby.com) and click on the support tab for this product.

## Meaning of Special Language

The following terms are used throughout the product literature to indicate various levels of potential harm when operating this product:

The purpose of safety symbols is to attract your attention to possible dangers. The safety symbols, and their explanations, deserve your careful attention and understanding. The safety warnings do not by themselves eliminate any danger. The instructions or warnings they give are not substitutes for proper accident prevention measures.

**NOTICE:** Procedures, which if not properly followed, create a possibility of physical property damage AND a little or no possibility of injury.

**CAUTION:** Procedures, which if not properly followed, create the probability of physical property damage AND a possibility of serious injury.

**WARNING:** Procedures, which if not properly followed, create the probability of property damage, collateral damage, serious injury or death OR create a high probability of superficial injury.



**Safety Alert:** Indicates warning or caution. Attention is required in order to avoid serious personal injury.



**WARNING:** Read the ENTIRE instruction manual to become familiar with the features of the product before operating. Failure to operate the product correctly can result in damage to the product, personal property and cause serious injury.

This is a sophisticated hobby product for advanced helicopter pilots with previous experience in the operation of CCPM helicopters (Cyclic Collective Pitch Mixing or Collective Pitch Helicopter) such as the Blade SR, Blade mCP X or Blade 300 X. It must be operated with caution and common sense and requires some basic mechanical ability. Failure to operate this product in a safe and responsible manner could result in injury or damage to the product or other property. This product is not intended for use by children without direct adult supervision. Do not attempt disassembly, use with incompatible components or augment product in any way without the approval of Horizon Hobby, Inc. This manual contains instructions for safety, operation and maintenance. It is essential to read and follow all the instructions and warnings in the manual, prior to assembly, setup or use, in order to operate correctly and avoid damage or serious injury.

**Age Recommendation: For advanced fliers ages 14 and above. This is not a toy.**

## General Safety Precautions and Warnings

This model is controlled by a radio signal subject to interference from many sources outside your control. Interference can cause momentary loss of control.

- Always ensure you fully understand the controls on your transmitter and how they affect the movement of the helicopter.
- Always operate your model outdoors in large, open spaces away from full-size vehicles, traffic and people to avoid collisions or injury
- Always carefully follow the manufacturers directions and warnings for any related equipment (i.e., chargers, rechargeable battery packs, etc.).
- Always keep the product, related chemicals, small parts and electrical components out of the reach of children.
- Always keep children out of the vicinity of this product at all times.
- Always store this product well out of the reach of children.
- Always keep hair secured above your shoulders so it cannot get caught in the blades.
- Always avoid water exposure to all equipment not specifically designed and protected for this purpose. Moisture causes damage to electronics.
- Never maintain and operate this product at night, in rain or in inclement weather.
- Always ensure all fasteners are secure before use.
- Always store product in a dry, temperate, secure location
- Do not touch the motor as it can become extremely hot during use.
- Do not fly this helicopter indoors
- Always ensure failsafe is properly set before flying. Do not exclusively rely on the safety mechanisms built into your transmitter and receiver.
- Always ensure you understand the product and how to operate it.
- Only use Horizon-approved replacement parts and accessories for this product.
- Never place any portion of the model in your mouth as it could cause serious injury.
- Never operate your transmitter or helicopter with low transmitter batteries.
- Never connect the battery unless using or testing the product. Do not perform maintenance with the battery installed.
- Never operate this product if you are tired, ill, taking any medications that impair judgment or are under the influence of alcohol or drugs.
- Never spray glass cleaner or any other liquid on this product.
- Always keep hair and dangling or loose items well away from the blades when the battery is connected.

**NOTICE:** Modification with non-Horizon-approved components may result in refusal of service by Horizon.



**WARNING:** This is a large model helicopter with carbon fiber blades that spin at very high RPM. Always use extreme caution and common sense when maintaining and operating this product. If you are unsure about ANY function or procedure described in this manual, DO NOT operate. Contact Horizon Product Support for assistance.



**WARNING:** Always ensure you are operating the helicopter a safe distance, 45 feet (13 meters), away from yourself and others.

# BLADE® 550X

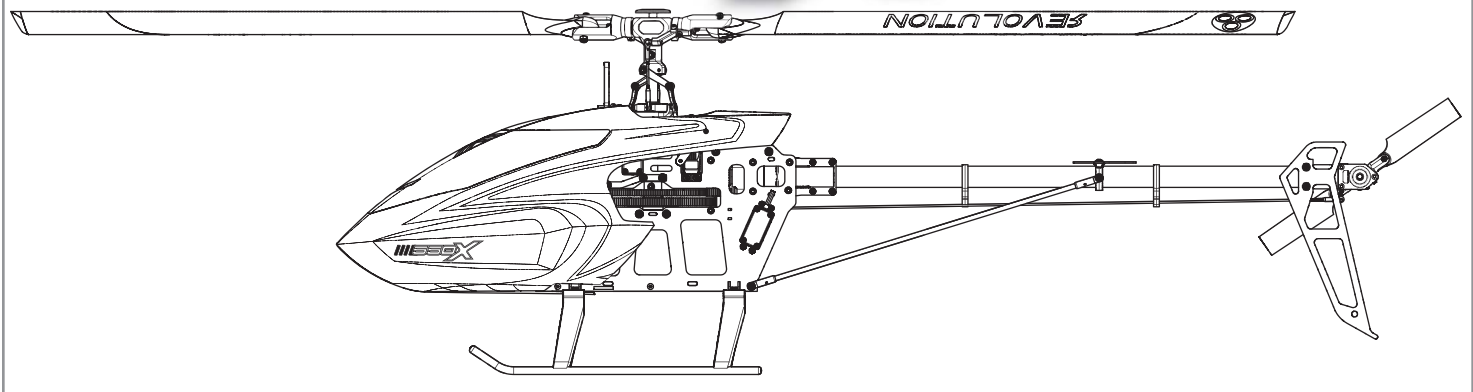

Welcome to the world of *Blade*® Pro Series helicopter performance. Over two decades of flying and design experience has gone into the development of the *Blade 550 X*. Every part, down to the nuts and bolts, has been chosen or designed with one goal in mind – giving you a no-compromise, 550-size 3D machine that is second to none.

Before you tear into the contents of this box, however, you must review this manual. It's been written and designed to make assembling the *Blade 550 X* one of the most enjoyable, hassle-free building experiences you'll ever have. Every step is clearly illustrated and shows what parts are needed to complete it. You'll find helpful building tips too.

## Table of Contents

Tools Needed to Complete .....	4	Control Test.....	18
Required Items .....	4	Low Voltage Cutoff.....	20
Optional Items .....	4	Flight Guidelines and Warnings .....	20
Assembly Guide.....	4	Flying Your 550X.....	20
Head Assembly (H).....	5	Blade Tracking .....	21
Frame Assembly (F) .....	7	Adjusting the Rudder Gain.....	21
Tail Assembly (T).....	10	Post Flight Inspection and Maintenance Checklist .....	21
Electronics Installation.....	13	AR7200BX Fine-Tuning and Adjustment .....	21
Servo Arms and Links .....	15	Troubleshooting Guide .....	22
Main Rotor Installation .....	15	Limited Warranty .....	23
Canopy Installation .....	15	Customer Service Information.....	24
Programming Your Transmitter .....	16	Compliance Information for the European Union.....	25
Throttle Hold.....	16	Exploded Views.....	98-100
AR7200BX Setup .....	17	Parts List / Ersatzteile / Pièces de rechange / Pezzi di ricambio.....	101-103
AR7200BX Parameter Menu Tips .....	17	Optional Parts / Optionale Bauteile / Pièces optionnelles / Pezzi opzionali.....	103
Motor Direction Test.....	17		

Blade 550 X Specifications			
Length	44.5 in (1130mm)	Tail Rotor Diameter	9.45 in (240mm)
Height	10.8 in (275mm)	Flying Weight	7.4–7.7 lb (3350–3500 g)
Main Rotor Diameter	49 in (1245mm)		

Component	Kit	Combo
Motor	Heli 550 Brushless Outrunner Motor, 1360Kv	included included
ESC	130 Amp Brushless ESC	included included
BEC	10 Amp BEC	included included
Battery	6S 22.2V 5000mAh 30C + Li-Po	required required
Charger	DC Li-Po Balancing Charger	required required

Component	Kit	Combo
Transmitter	DSM2®/DSMX® compatible transmitter	required required
Receiver	AR7200BX 7CH DSMX Flybarless Control System	required included
Swash Servos	Spektrum™ H6040	required included
Tail Servo	Spektrum H6080G	required included

To register your product online, visit [www.bladeheli.com](http://www.bladeheli.com)

## Tools Needed To Complete

- 1.5mm, 2mm, 2.5mm, and 3mm hex drivers
- Ball link pliers
- Needle nose pliers
- Phillips screwdriver
- Wire cutter
- Pitch gauge
- Metric calipers
- Petroleum based, light viscosity lube
- Medium cyanoacrolate (CA)

## Required Items

- Receiver/Flybarless control unit  
AR7200BX (SPMAR7200BX)  
included with combo BLH5525C

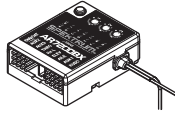

- DSMX Remote Receiver (SPM9645)  
included with combo BLH5525C

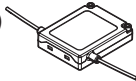

- 3 Servos  
(3) H6040 servos (SPMSH6040)  
included with combo BLH5525C



- 1 Tail servo  
(1) H6080G servo (SPMSH6080G)  
included with combo BLH5525C



- 5000mAh 6S 22.2V 30C LiPo,  
10AWG with EC5™ connector  
(EFLB50006S30)



- E-flite® EC5 Device Charge  
Lead with 6" Wire & Jacks,  
12 AWG and EC5 connector  
(EFLAEC512)

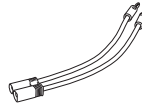

- E-flite 200W charger (EFLC3020)



- Celecra™ 15VDC 250W  
Power Supply (EFLC4010)

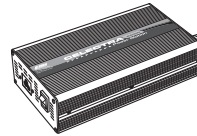

- DSM2®/DSMX® compatible DX6i 6 channel  
transmitter or higher

## Optional Items

- Dynamite® Li-Po Charge  
Protection Bag, Large  
(DYN1405)

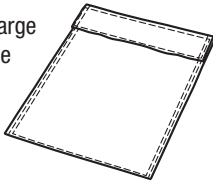

- Control Rod Set Up Tool  
(RVO1004)

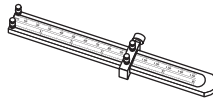

## Assembly Guide Legend



Apply BLUE Threadlock



Apply Petroleum based,  
light viscosity lube



Loosely Tighten



Apply NO Threadlock



Apply Synthetic Grease



Fully Tighten



Apply MEDIUM CA

**2X**

Repeat Multiple Times

# Head Assembly (H)

## Step H1

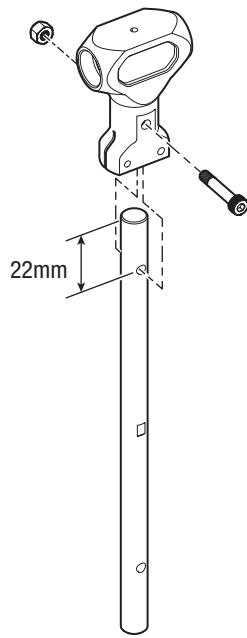

## Step H1 parts (bags H1 and H2)

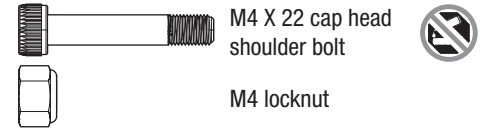

## Step H2

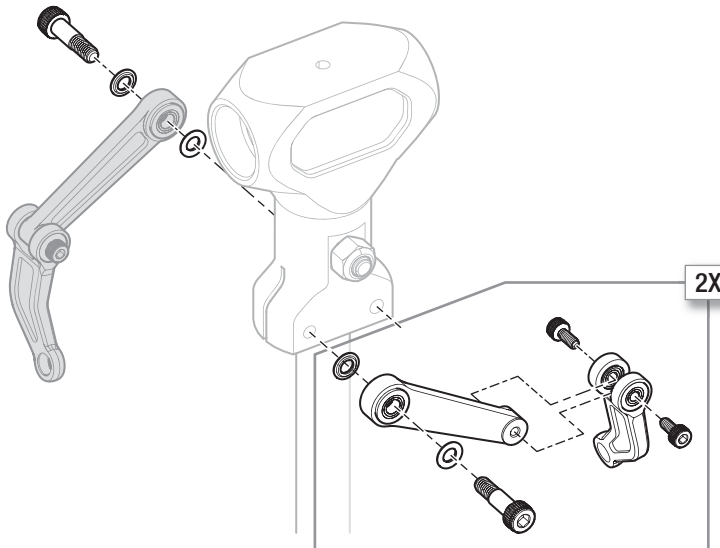

## Step H2 parts (bag H1)

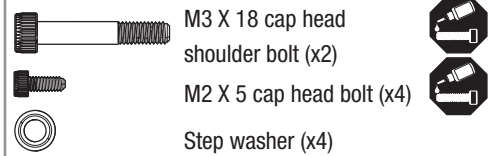

- The stepped sides of the washers should face the radial bearings.
- Do not over-tighten. The follower arms should move freely.

## Step H3

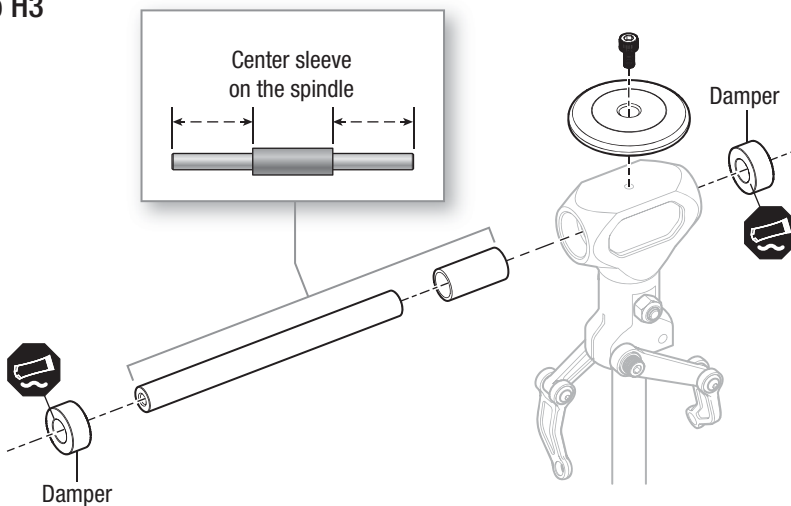

## Step H3 parts (bags H1 and H2)

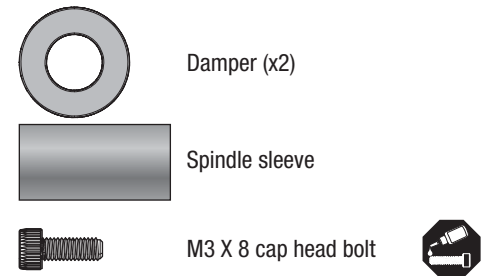

- Clean the threads in the spindle thoroughly with alcohol before installation.

# Head Assembly cont'd

## Step H4 parts (bag H3)

Thrust bearing (x2)

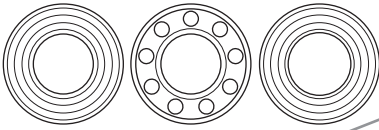

Thrust washer  
10 X 14 X .8 (x2)

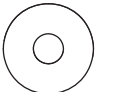

Spindle bolt washer  
4 X 12 X 1 (x2)

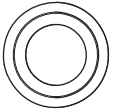

Step washer (x2)

**A** M4 X 12 bolt (x2)

**B** M3 X 14 bolt (x2)

**C** M3 X 8 bolt (x2)

Control ball (x2)



## Step H4

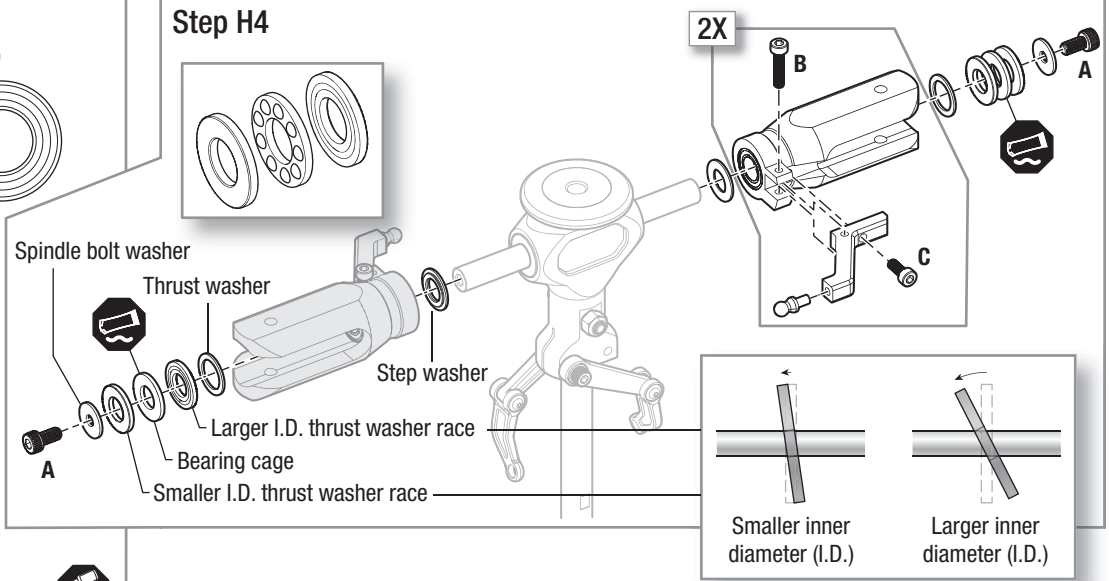

**WARNING:** Any time you loosen the spindle bolts, completely clean the bolts with denatured alcohol making sure you have removed any residual oil. When putting bolts back on, apply medium-strength threadlock to the bolts and allow time for the threadlock (about 4 to 6 hours) to dry before attempting to fly your helicopter.

- Loosely install bolts B and C before tightening.
- The stepped washer faces the radial bearing in the blade grip.

## Step H5 parts (bag H4)

## Step H5

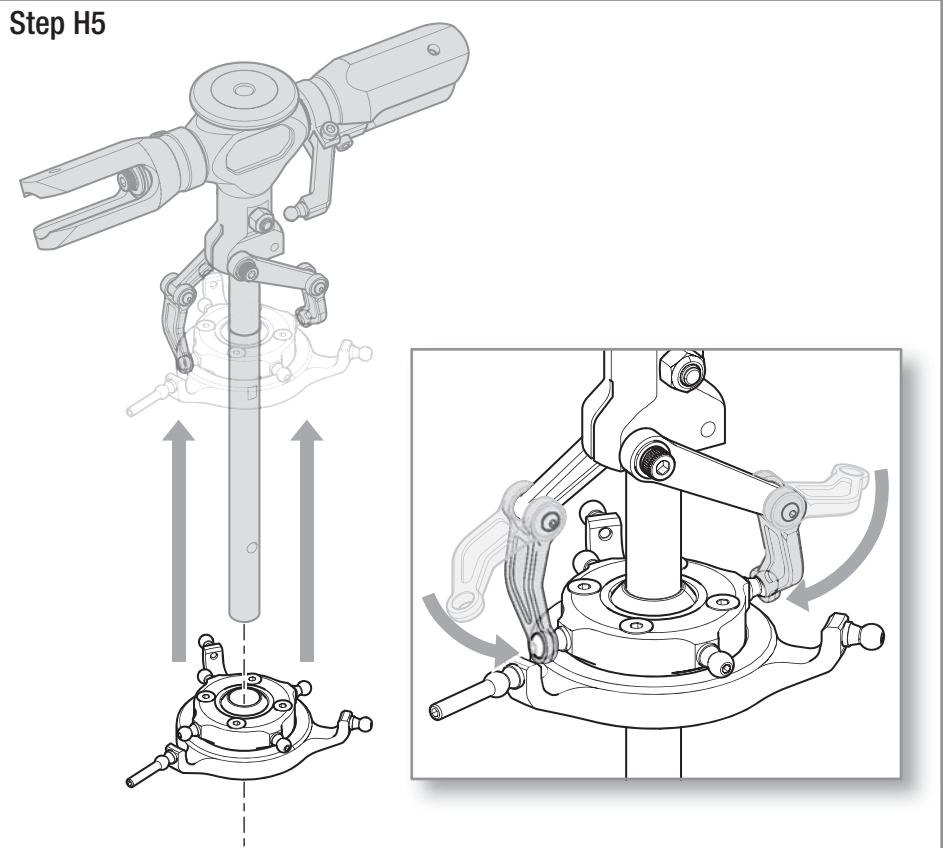





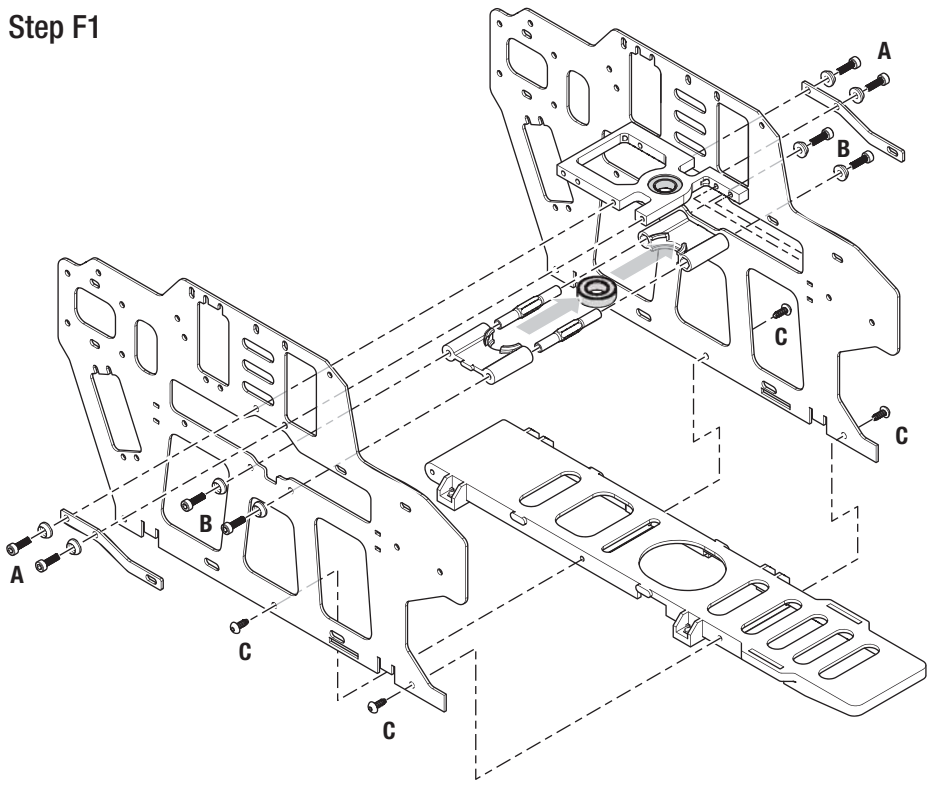

# Frame Assembly (F)

**ASSEMBLY NOTE:** Before assembly, plan your wire routing for the servos. At any point where the servo wire is going to pass through or cross the frame plates, use sandpaper to round the edge of the frame plate to prevent the wire from chafing.

## Step F1



## Step F1 parts (bags F1, F2, and F3)

- A**  Cap head bolt M3 X 10 (x4)  
- B**  Cap head bolt M3 X 14 (x4) 
- C**  Self tapping screw M3 X 8 (x4)
-  M3 recessed washer (x8)



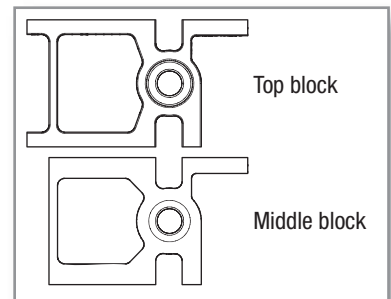

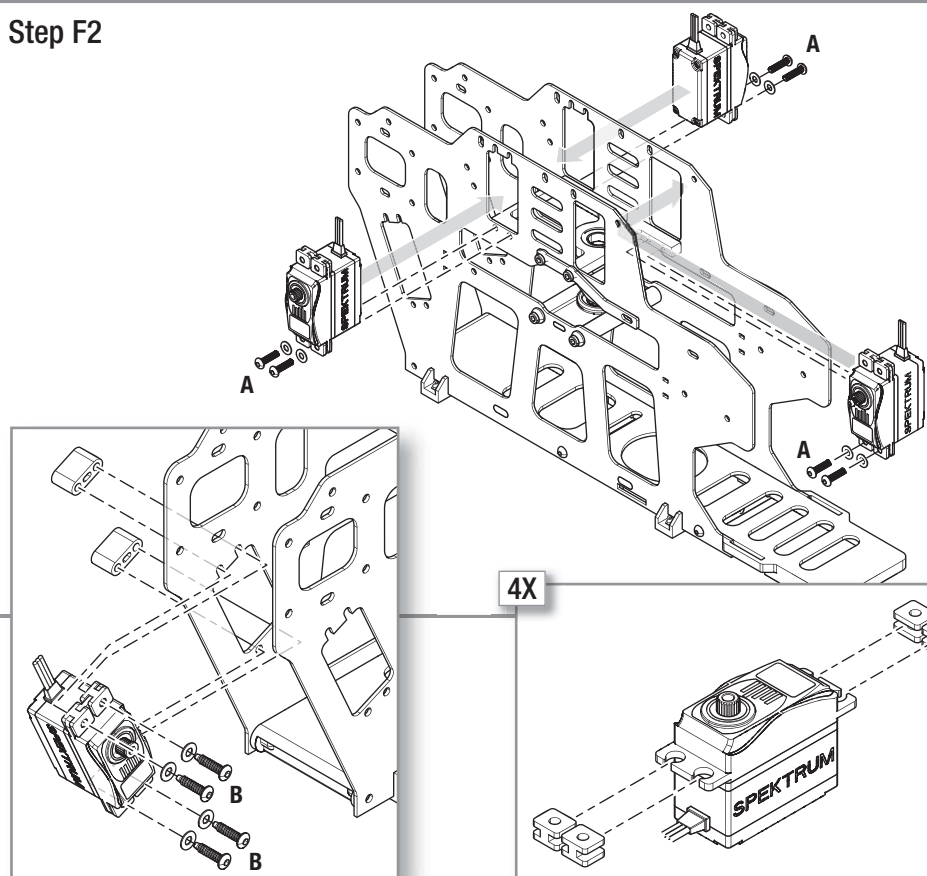

• At this stage of the assembly, do not tighten the bearing blocks or bottom plate screws.



## Step F2



## Step F2 parts (bag F5)

- A**  Button head screw M3 X 12 (x6)  
- B**  Self tapping screw M3 X 12 (x4) 
-  Servo washers (x10)

## Frame Assembly cont'd

### Step F3 parts (bags F3 and F5)

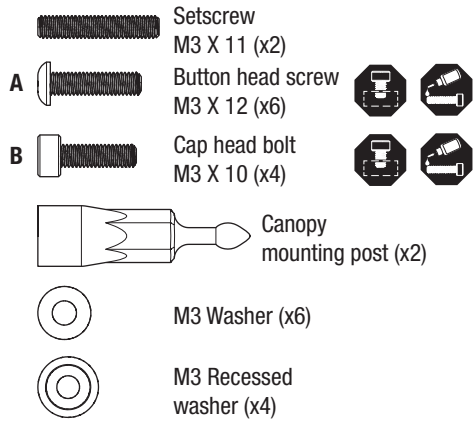

- Slide the mainshaft into position, then tighten all the frame and servo screws.

### Step F3

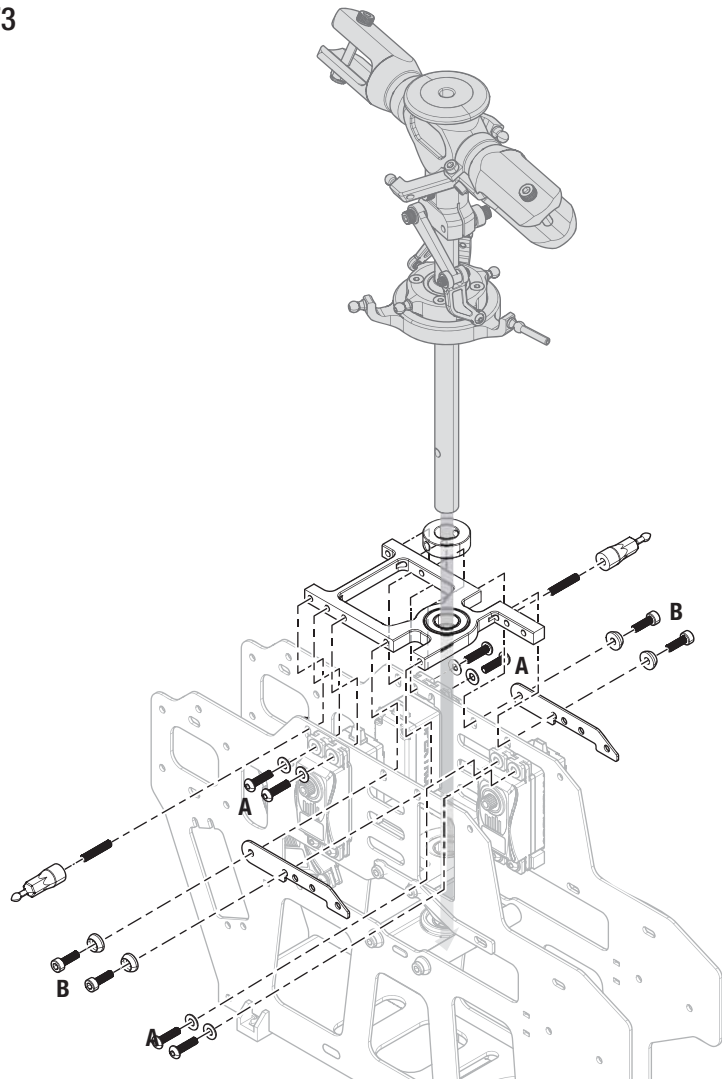

### Step F4 parts (bag F3)

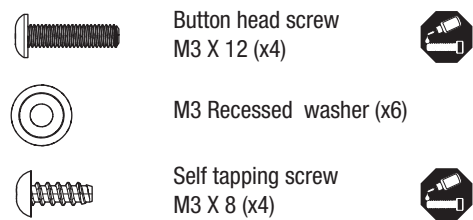

### Step F4

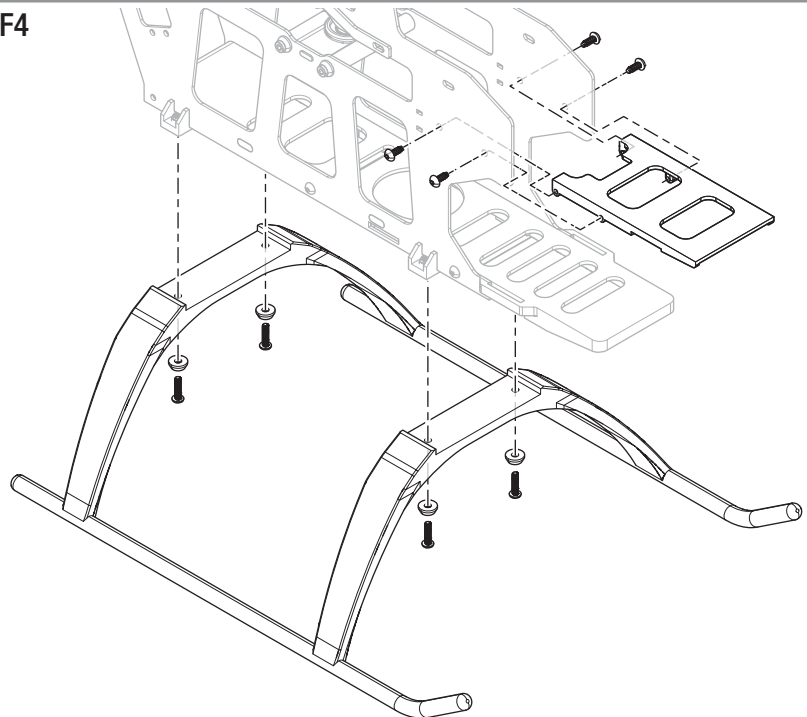



# Frame Assembly cont'd

## Step F5

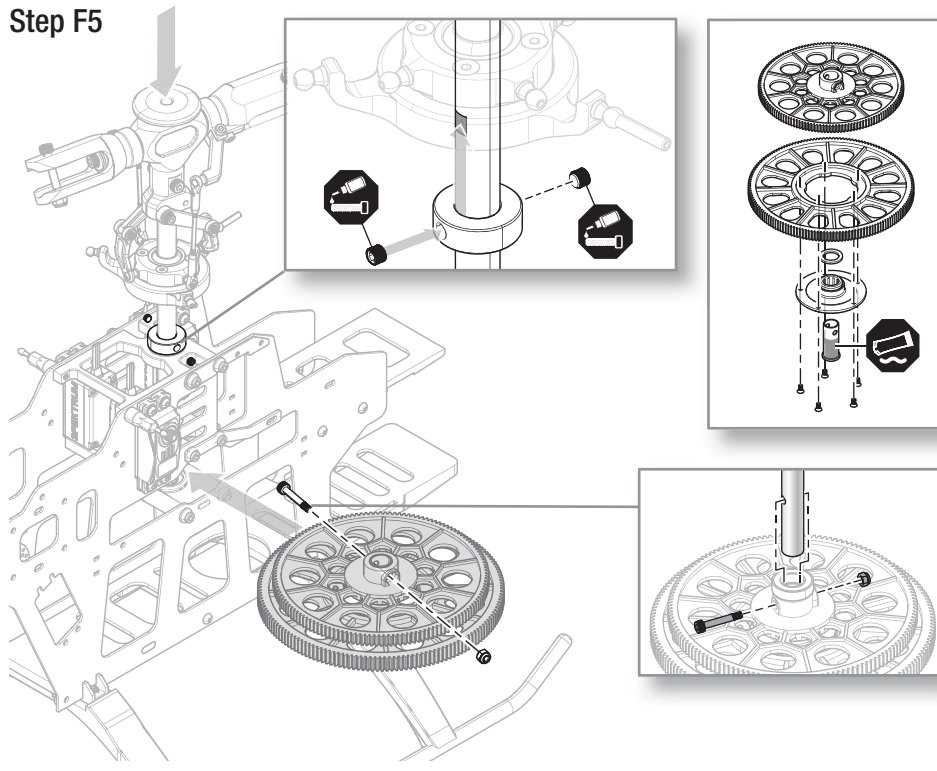

## Step F5 parts (bag M1)

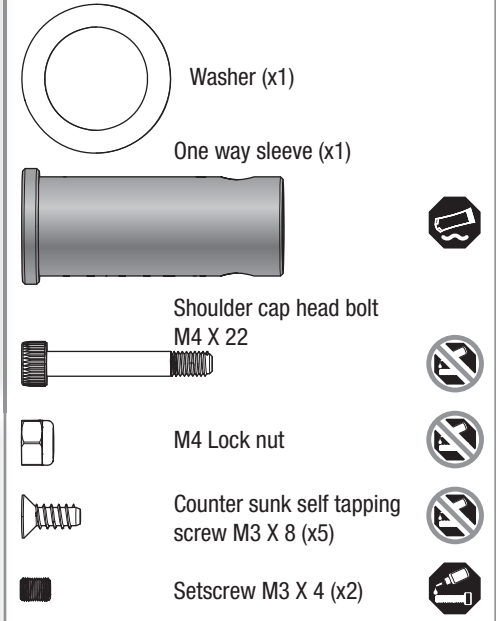

## Step F6

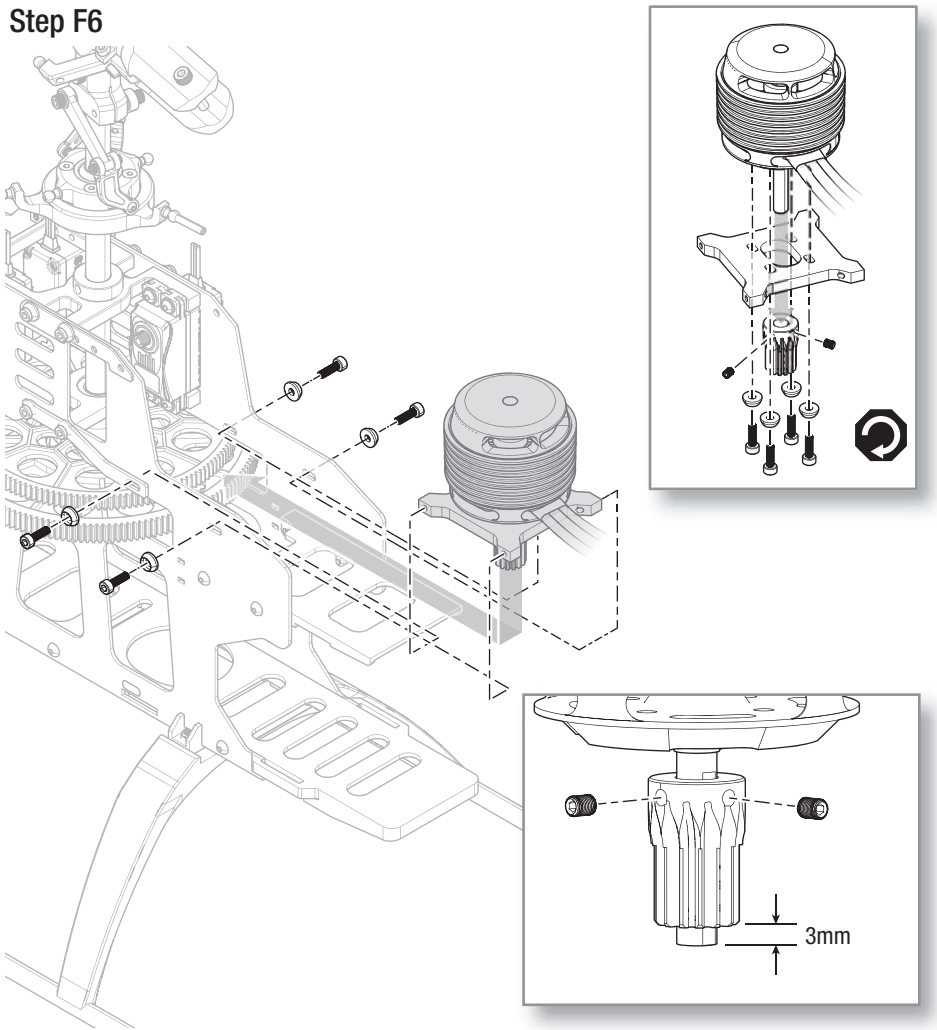

## Step F6 parts (bag F6)

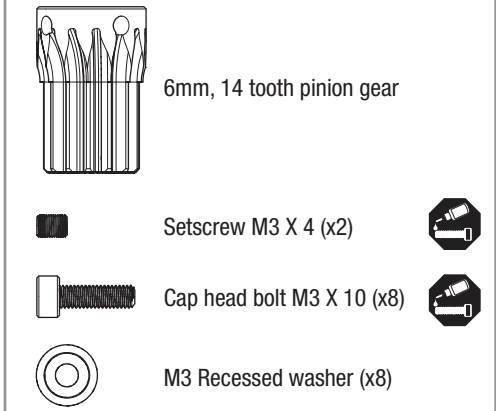

# Tail Assembly (T)

## Step T1 parts (bag T1)

Hexagonal posts (x6)



Radial bearing  
12 X 18 X 4 (x2)

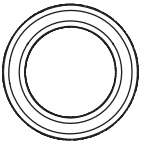

Radial bearing  
5 X 10 X 4 (x2)



Brass spacer



Cap head shoulder  
bolt M3 X 18 (x4)

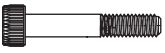

M3 Lock nut (x4)



## Step T1

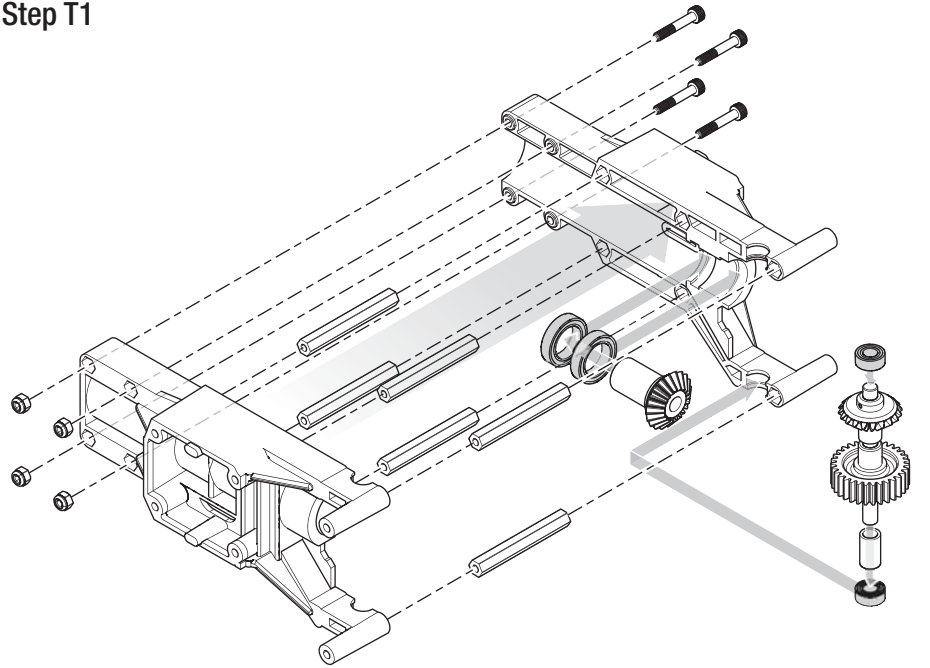

## Step T2 parts (bag T1)

Button head self tapping  
screw M3 X 12 (x12)

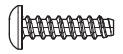

## Step T2

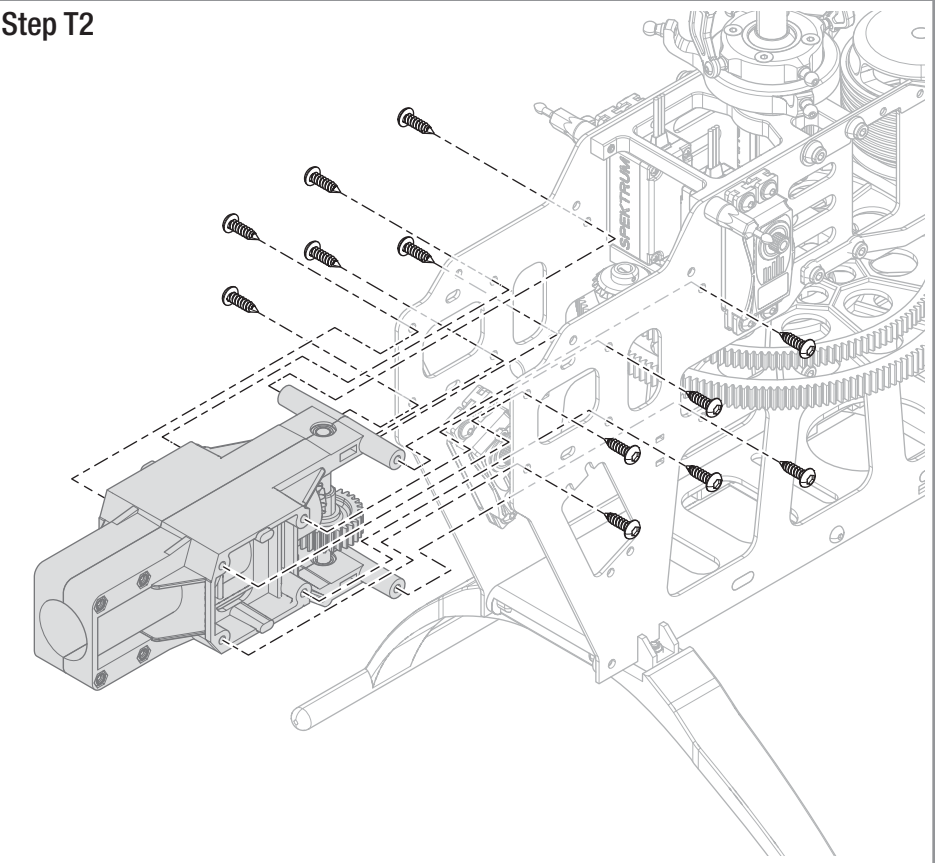

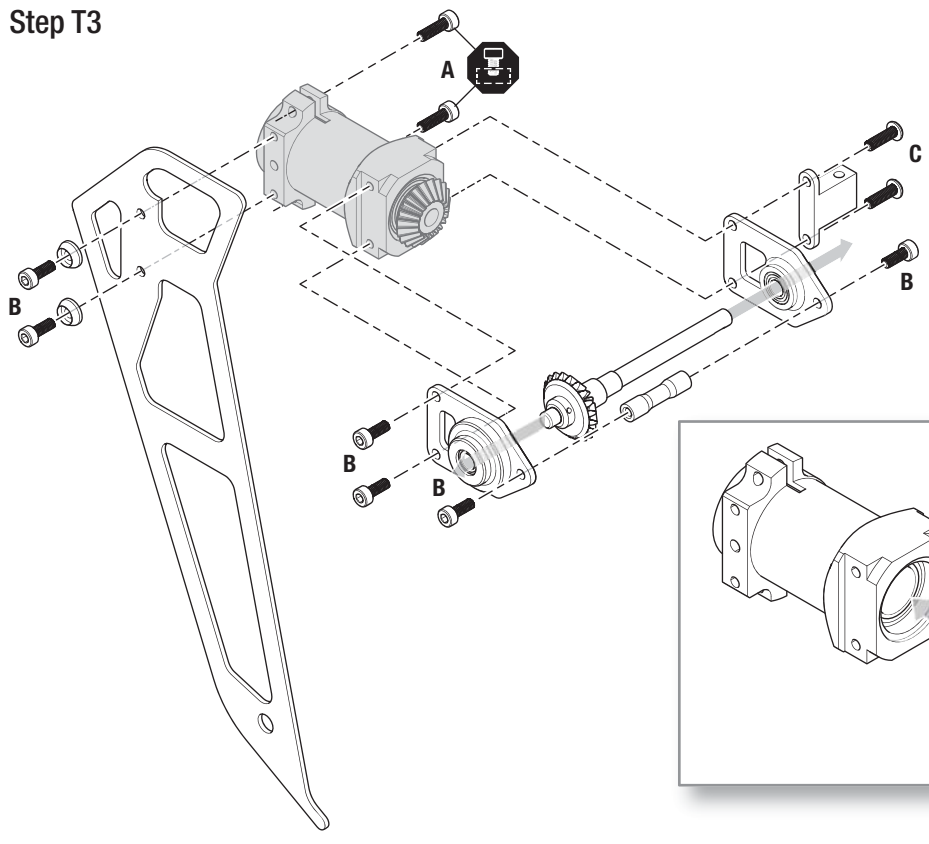

# Tail Assembly cont'd

## Step T3









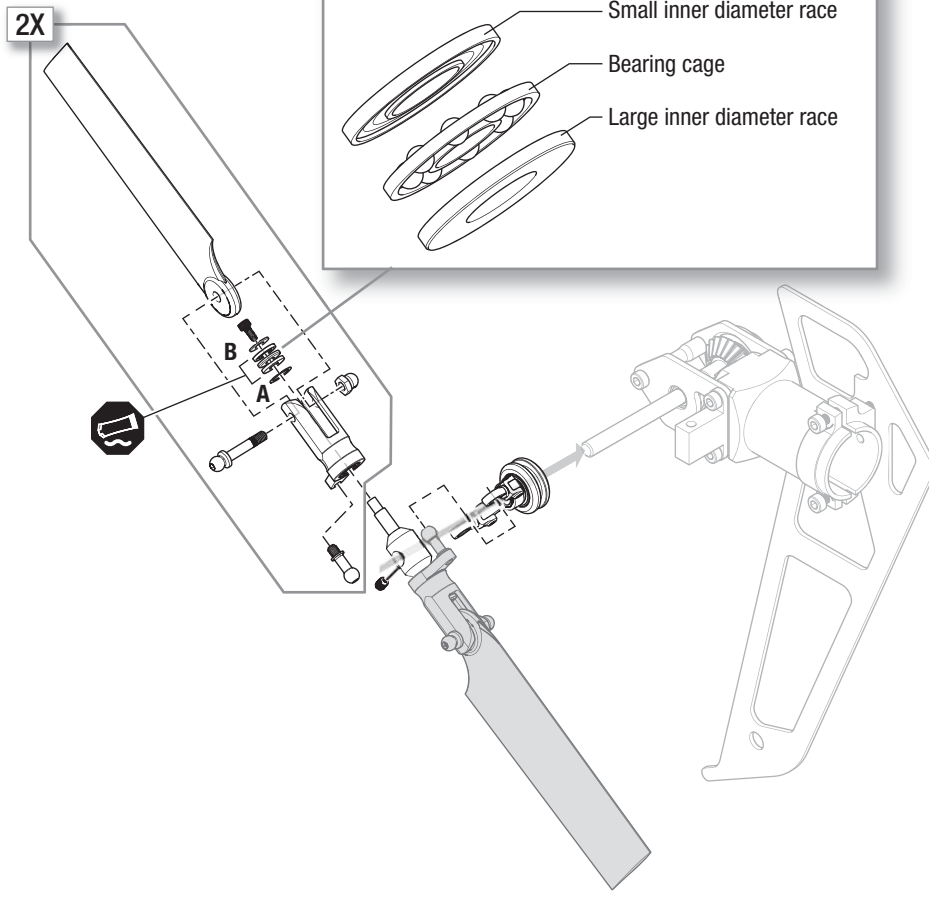

## Step T3 parts (bags T2 and T3)

- A**  Cap head bolt M3 X 10 (x2)
- B**  Cap head bolt M3 X 8 (x4)
- C**  Button head screw M3 x 10 (x2)
-  M3 Recessed washer (x2)

## Step T4



## Step T4 parts (bags T4 and T5)

-  Tail blade bolt (x2)
-  Tail blade nut (x2)
-  Thrust bearing (x2)
- A**  Thrust washer (x2)
-  Control ball (x2)
-  M4 x 3 Set screw
-  M3 X 8 Cap head bolt (x2)
- B**  M3 Washer (x2)

## Tail Assembly cont'd

### Step T5 parts (bag T6)

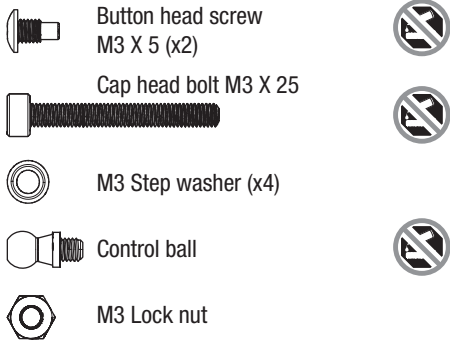

- The stepped side of the washer faces the radial bearing.

### Step T5

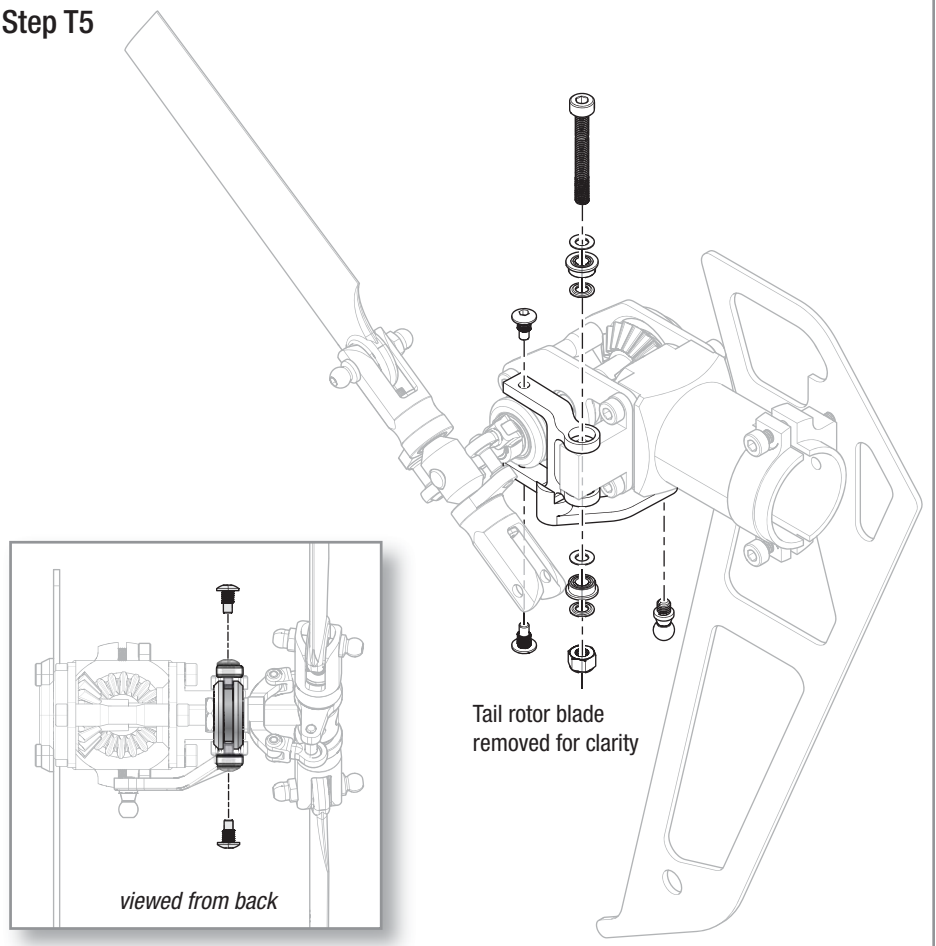

### Step T6a parts (bag T7)

- Glue the torque tube bearings in place by placing a thin bead of CA on the torque tube at the given locations (200mm, 200mm), then slide the bearings onto the CA. Do not allow CA to get into the bearings.
- Use oil on the outside of the torque tube bearing holders to ease installation into the boom.

### Step T6a

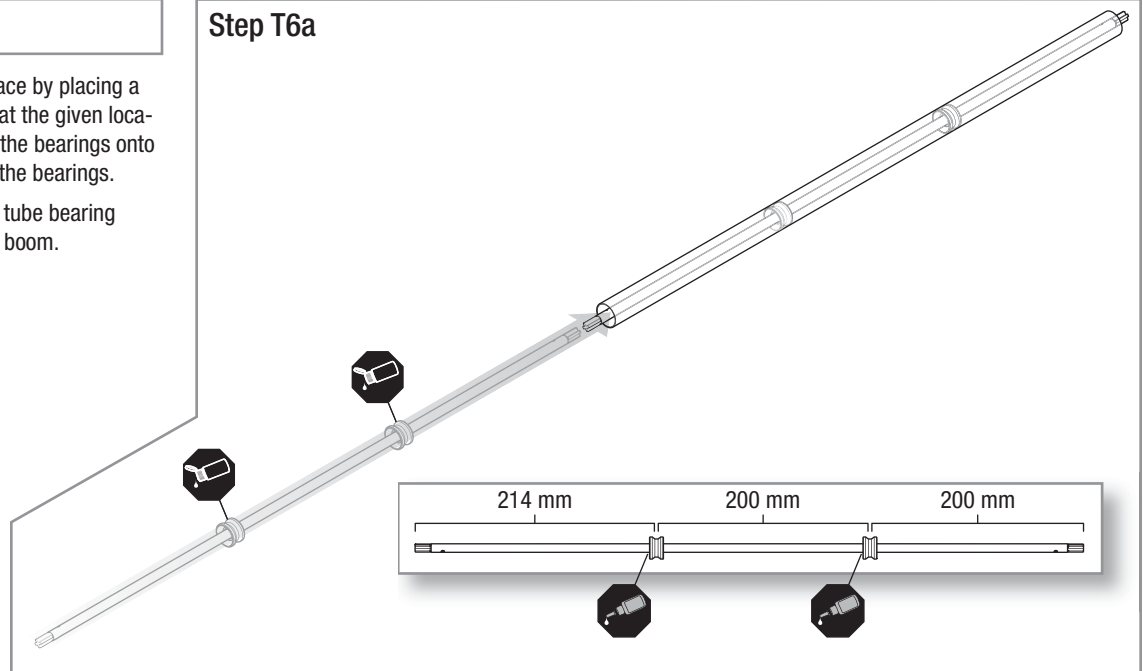

## Tail Assembly cont'd

### Step T6b

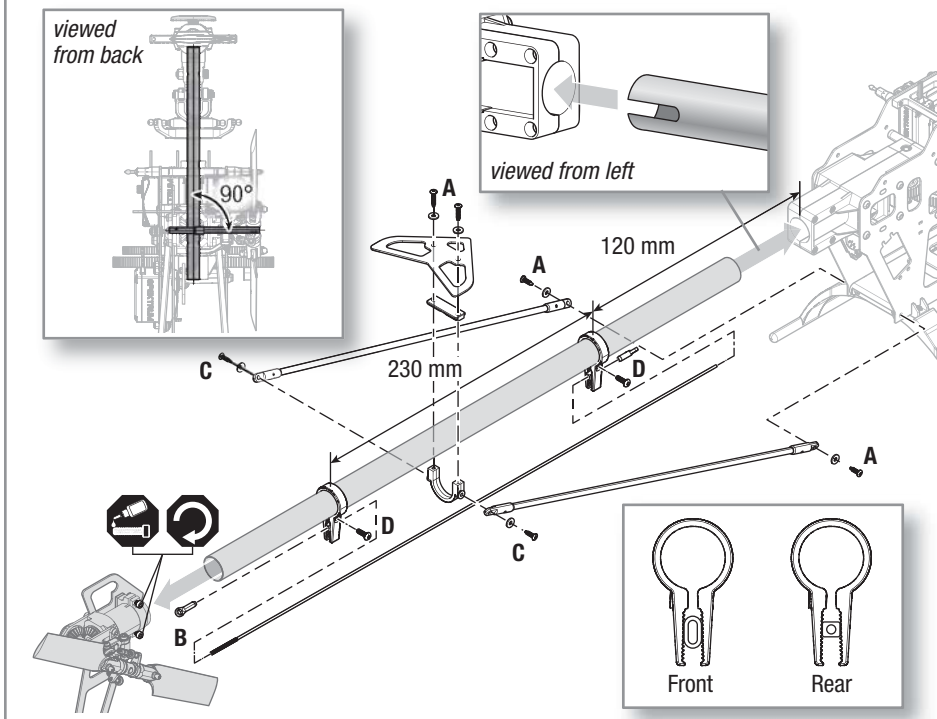

### Step T6b parts (bags T8 and T3)

- A** Self tapping screw M3 X 12 (x4)
- B** Self tapping screw M2.5 X 8 (x2)
- M3 Recessed washer (x6)
- Ball link (x2)
- Rear pushrod guide insert
- Front pushrod guide insert

## Electronics Installation (E)

### Flybarless Control Unit and Remote Receiver

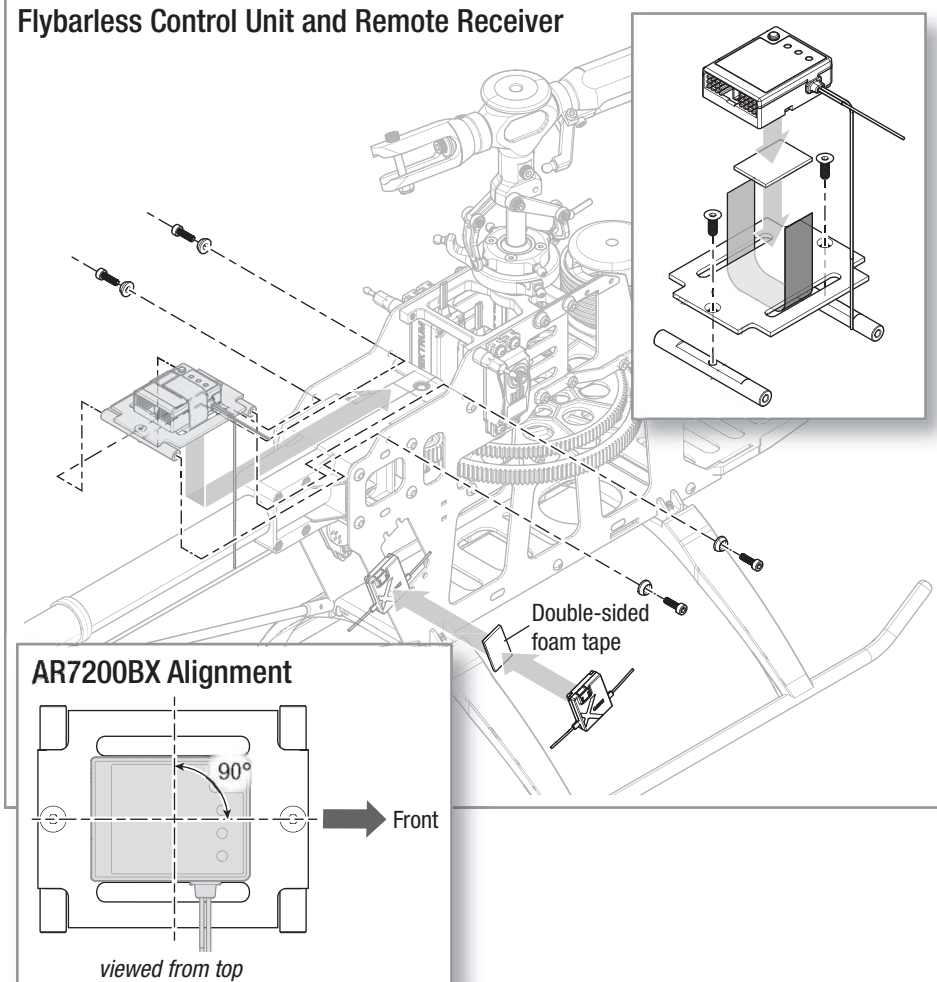

### Step E1 parts (bag E1)

- Cap head M3 X 10 (x4)
- Recessed washer (x4)
- Counter sunk screw M3 X 8 (x2)

#### AR7200BX servo connections

BIND/DAT	Bind plug, telemetry module or data logger (optional)
AUX2	BEC
AUX3	BEC
THRO	Speed control
Rx L	Remote receiver
ELEV	Center swashplate servo
AILE	Left swashplate servo
AUX1	Right swashplate servo
RUDD	Tail servo

**TIP:** Connect the remote receiver before plugging in the servo leads.

## Electronics Installation cont'd

### AR7200BX Arming

1. Lower the throttle.
2. Power on the transmitter.
3. Center the throttle trim.
4. Turn throttle hold ON.
5. Attach hook material to the helicopter frame and loop material to the battery.
6. Install the flight battery on the helicopter frame. Secure the flight battery with a hook and loop strap.
7. Connect the battery cable to the ESC.
8. Do not move the helicopter until the AR7200BX initializes. The swashplate will move up and down, indicating that the unit is ready. The AR7200BX will also emit a solid BLUE Status LED when it is ready.
9. The helicopter motor will emit a series of tones, indicating the ESC is armed.

**CAUTION:** Always disconnect the Li-Po battery from the aircraft receiver when not in use to avoid over-discharging the battery. Batteries discharged to a voltage lower than the lowest approved voltage may become damaged, resulting in loss of performance and potential fire when batteries are charged.

### Speed control and BEC

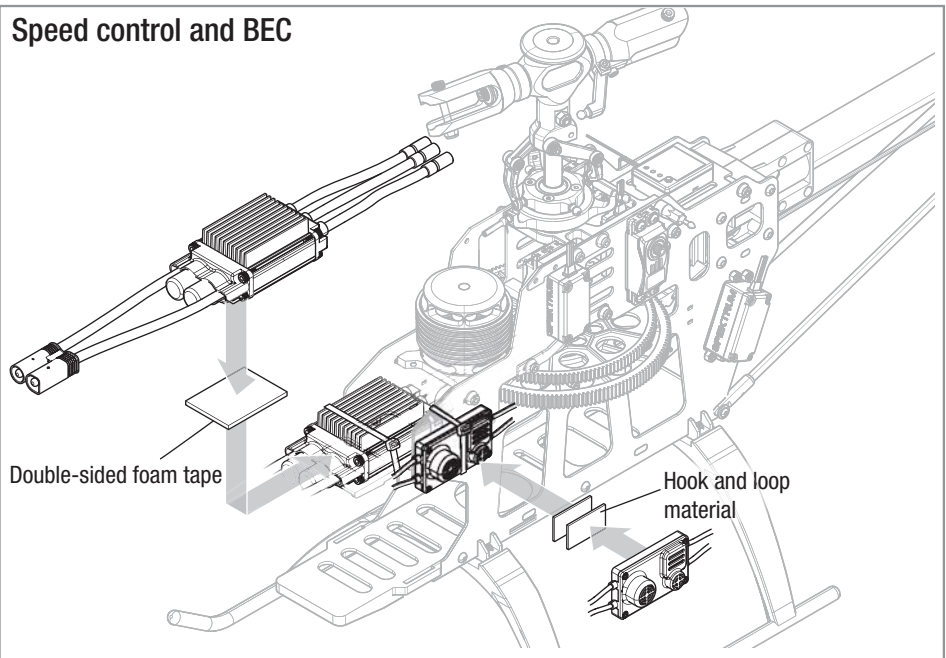

### Flight battery

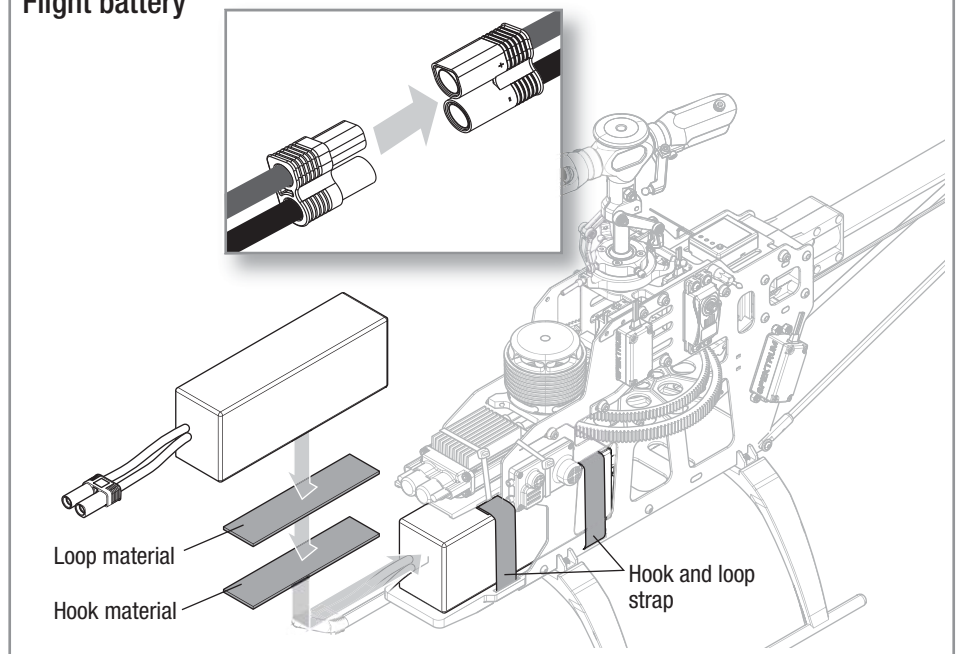

# Servo Arms and Links Installation

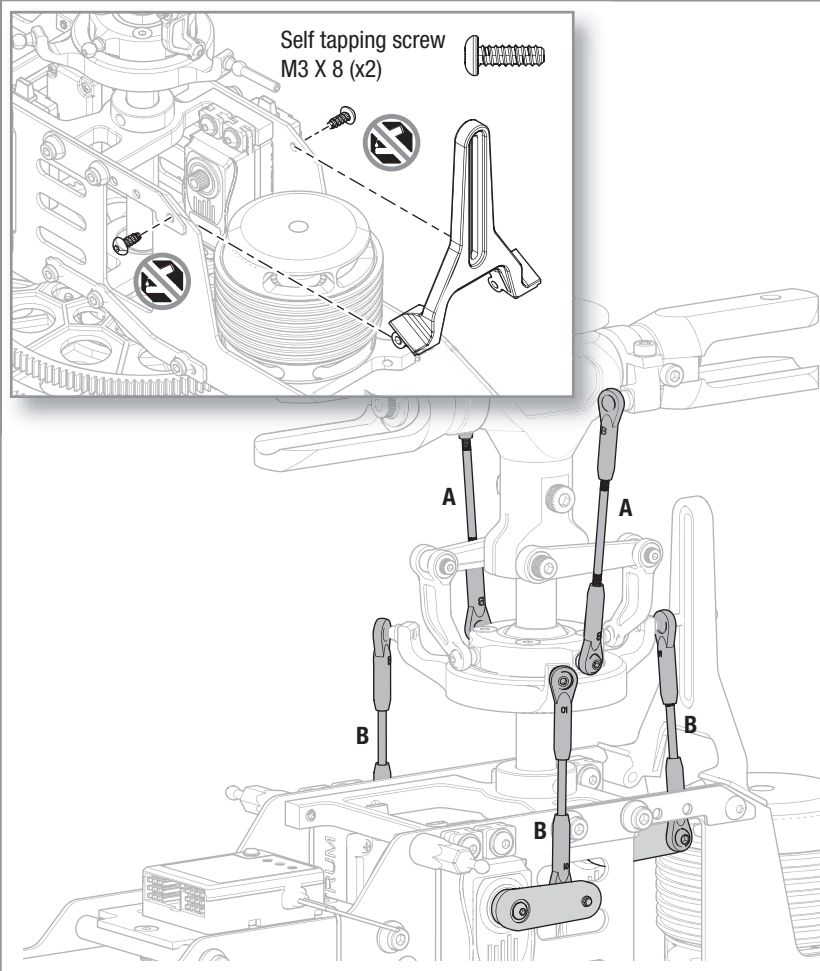

## Servo ball link placement

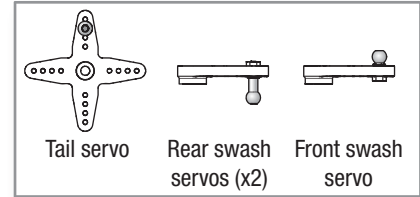

## Tail pushrod alignment

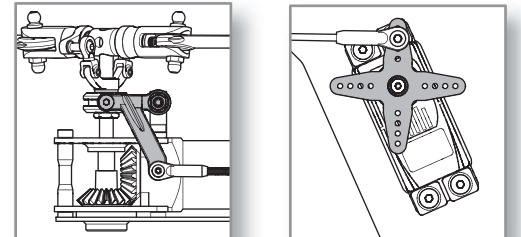

Tail pitch bellcrank neutral position (viewed from the bottom)

Tail servo arm neutral position (viewed from the right side)

## Pushrod lengths

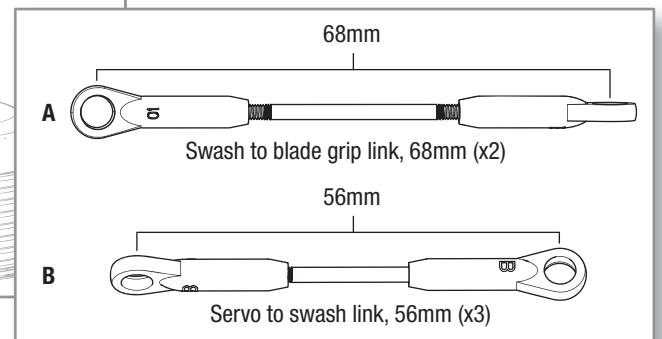

# Main Rotor Installation

## Main Rotor Blades

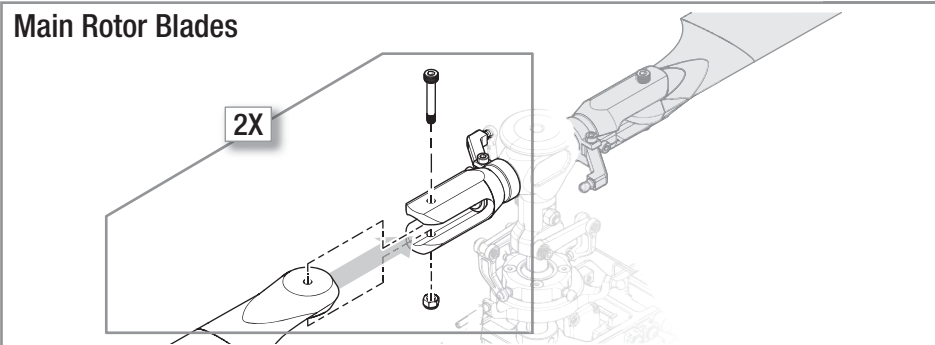

## Main Rotor Blade parts

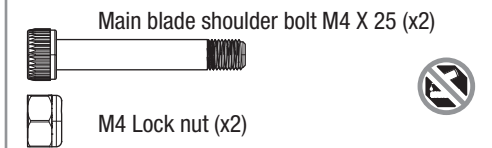

- The rotor blades should be tight enough to hold their position if you hold the helicopter sideways, but loose enough to swing freely if you move the helicopter and stop abruptly.

# Canopy Installation

## Canopy Grommets

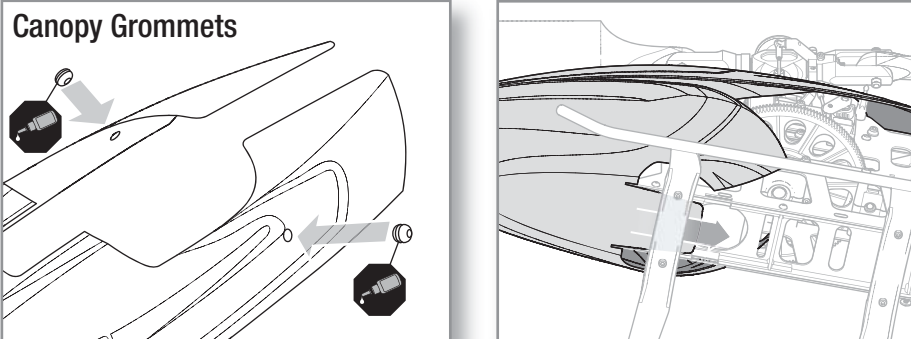

# Programming Your Transmitter

Program your transmitter before attempting to bind or fly the helicopter. Transmitter programming values are shown below for the *Spektrum* DX6i, DX7/DX7se, DX7s, DX8, and DX18. The files for models using *Spektrum*™ transmitters with *AirWare*™ software are also available for download online in the Spektrum Community.

DX6i		DX7/DX7se	
<b>SETUP LIST</b>	<b>ADJUST LIST</b>	<b>SYSTEM LIST</b>	<b>FUNCTION MODE</b>
<b>Model Type</b> HELI	<b>D/R &amp; Expo</b> 0-AILE 100% 30% 0-ELEV 100% 30% 0-RUDD 100% INH 1-AILE 85% 30% 1-ELEV 85% 30% 1-RUDD 85% INH	<b>Model Type</b> HELI	<b>D/R &amp; EXP</b> 0-AILE 100% 30% 0-ELEV 100% 30% 0-RUDD 100% INH 1-AILE 85% 30% 1-ELEV 85% 30% 1-RUDD 85% INH
<b>Reverse</b> THRO N AILE R ELEV R RUDD N GYRO N PITC R	<b>Thro Curve</b> NORM 0% 40% 80% 80% 100% STUNT 100% 100% 100% 100% 100% HOLD 10% 10% 10% 10% 10%	<b>Swash Type</b> 1 Servo 90	<b>Thro Curve</b> NORM 0% 40% 60% 80% 100% ST-1 100% INH 80% INH% 100% ST-2 100% 100% 100% 100% 100% HOLD 0% 0% 0% 0% 0%
<b>Swash Type</b> 1 Servo 90	<b>Pitc Curve</b> NORM 30% 40% 50% 75% 100% STUNT 0% 25% 50% 75% 100% HOLD 0% 25% 50% 75% 100%		<b>Pitc Curve</b> NORM 30% INH 50% INH 100% ST-1 0% INH 50% INH 100% ST-2 0% INH 50% INH 100% HOLD 0% INH 50% INH 100%
<b>Timer</b> 4:00	<b>Travel Adj</b> THRO 100% AILE 100% ELEV 100% RUDD 100% GYRO 100% PITC 100%		<b>Travel Adj</b> THRO 100% AILE 100% ELEV 100% RUDD 100% GEAR 100% PIT. 100%
	<b>Gyro</b> Rate SW-F. Mode NORM 84% STUNT 84%		<b>Reversing SW</b> THRO N RUDD N AILE R GEAR N ELEV R PIT. N
			<b>Gyro SENS</b> AUTO F.MODE STNT 84% HOLD 84%
			<b>Timer</b> 4:00

## DX7s/DX8/DX18

SYSTEM SETUP	FUNCTION LIST	
<b>Model Type</b> HELI	<b>D/R &amp; Expo</b>	<b>Throttle Curve</b>
<b>Swash Type</b> 1 Servo Normal	0-AILE 100% 30% 0-ELEV 100% 30% 0-RUDD 100% 0% 1-AILE 85% 30% 1-ELEV 85% 30% 1-RUDD 85% 0%	NORM 0% 40% 60% 80% 100% ST-1 100% 90% 80% 90% 100% ST-2 (DX8/18 only) 100% 100% 100% 100% 100% HOLD 0% 0% 0% 0% 0%
<b>F-Mode Setup</b> Flight Mode: F Mode Hold: Hold	2-AILE 85% 30% 2-ELEV 85% 30% 2-RUDD 85% 0%	<b>Pitch Curve</b> NOR 30% 40% 50% 75% 100% ST-1 0% 25% 50% 75% 100% ST-2 (DX8/18 only) 0% 25% 50% 75% 100% HOLD 0% 25% 50% 75% 100%
<b>Frame Rate</b> 11ms DSMX	<b>SERVO SETUP</b>	
	<b>Travel</b>	<b>Reverse</b>
	THRO 100% THRO N AILE 100% AILE R ELEV 100% ELEV R RUDD 100% RUDD N GEAR 100% GEAR N PIT. 100% PIT. N	<b>Timer</b> MODE Countdown TIME 4:00 Tone/Vibe START Throttle Out POS 25
		<b>Gyro</b> SW F Mode CH Gear NORMAL/POS 0 68% STUNT 1/POS 1 68% STUNT 2/POS 2 68% HOLD 68%

## Throttle Hold

When you move the throttle hold switch to the ON position, the helicopter motor turns off. You will still have control of the helicopter cyclic and rudder commands.

The blades spin if throttle hold is OFF. For safety, turn throttle hold ON any time you need to touch the helicopter or check the direction controls.

You should also turn throttle hold ON to minimize damage if the helicopter is out of control or in danger of crashing.

See your transmitter manual for more information on programming throttle hold.



## SETUP MENU *Menu LED solid*

Refer to the Spektrum AR7200BX manual for specific details.

Status-LED:		OFF	Purple	Red Flashing	Red Solid	Blue Flashing	Blue Solid
<b>A</b>	<b>Mounting orientation</b>				upright (vertical)		flat (horizontal)*
<b>B</b>	Swashplate servo - <b>frequency</b>	<b>User defined</b>	50 Hz	65 Hz	120 Hz	165 Hz	200 Hz*
<b>C</b>	Tail servo - <b>center position pulse length</b>	<b>User defined</b>	960 μs		760 μs		1520 μs*
<b>D</b>	Tail servo - <b>frequency</b>	<b>User defined</b>	50 Hz	165 Hz	270* Hz	333 Hz	560 Hz
<b>E</b>	Tail servo - <b>rotor endpoints</b>	Tail stick - move to right endpoint and wait/left endpoint and wait					
<b>F</b>	Tail - <b>sensor direction</b>				normal		reversed*
<b>G</b>	Swashplate - <b>servo centering</b>	Reference position	ELE center pos.		AIL center pos.		PIT center pos.
<b>H</b>	Swashplate - <b>mixer</b>	<b>User defined</b>	mechanical	90°	120°*	140°	140° (1=1)
<b>I</b>	Swashplate - <b>servo directions</b>	nor rev rev	nor nor rev*		nor rev nor		nor nor nor
<b>J</b>	Swashplate - <b>cyclic pitch geometry</b>	Aileron stick – adjust 6° cyclic pitch on the roll axis (blades aligned with fuselage)					
<b>K</b>	<b>Collective pitch range</b>	Collective stick on max and min position and use tail stick to adjust desired pitch. Stock settings provide +/- 14 degrees of collective pitch.					
<b>L</b>	Swashplate - <b>cyclic limit</b>	Move aileron, elevator and pitch sticks – adjust max limits with tail stick					
<b>M</b>	Swashplate - <b>sensor directions</b>	rev   rev	rev   nor		nor   rev		nor   nor*
<b>N</b>	<b>Pirouette optimization direction</b>				normal		reversed*

## PARAMETER MENU *Menu LED is flashing quickly*

Status-LED:		OFF	Purple	Red Flashing	Red Solid	Blue Flashing	Blue Solid
<b>A</b>	Swashplate - <b>cyclic center adjustment</b>	Aileron and elevator stick – reset with tail stick					
<b>B</b>	<b>Control behavior</b>	<b>User defined</b>	normal	sport*	pro	extreme	transmitter
<b>C</b>	Swashplate - <b>pitching up behavior</b>	<b>User defined</b>	very low	low	medium*	high	very high
<b>D</b>	Tail - <b>HeadingLock gain</b>	<b>User defined</b>	very low	low	medium*	high	very high
<b>E</b>	<b>Stick deadband</b>	<b>User defined</b>	1	2*	3	4	5
<b>F</b>	Tail - <b>torque precompensation IX</b>	<b>User defined</b>	off*	low - nor	high - nor	low - rev	high - rev
<b>G</b>	<b>Cyclic response</b>	<b>User defined</b>	normal*	slightly increased*	increased	high	very high
<b>H</b>	<b>Pitch boost</b>	<b>User defined</b>	off*	low	medium	high	very high

## AR7200BX Parameter Menu Tips

Refer to the Spektrum AR7200BX manual to fine tune the Blade 550 X to your flying and control style via the AR7200BX parameter menu.

If you would like to change the control behavior of the flybarless system to a pre-defined behavior in the AR7200BX, adjust parameter B (default behavior is transmitter).

If you would like to have the cyclic behavior to feel more linear OR more like a flybarred helicopter, increase the cyclic response by adjusting parameter G (default is 'normal').

Refer to the Spektrum AR7200BX manual for specific details on each parameter.

## Motor Direction Test

Place the helicopter outdoors on a clean, flat and level surface (concrete or asphalt) free of obstructions. Always stay clear of moving rotor blades.

1. Power on the transmitter. Make sure TH HOLD is ON and the flight mode switch is in the normal position.

**WARNING:** The motor will spin when throttle is increased and TH HOLD is OFF.

2. Lower the throttle completely.

**WARNING:** Stay at least 45 feet (13 meters) away from the helicopter when the motor is running.

3. Connect the Li-Po battery to the ESC.

4. Turn TH HOLD OFF. Slowly increase the throttle until the drive train begins to turn. The main blades spin clockwise when viewing the helicopter from the top. The tail rotor blades spin counterclockwise when viewing the helicopter from the right-hand side.

**NOTICE:** If the drive train does not turn with the motor or spins counterclockwise, turn TH HOLD ON. Disconnect the battery from the helicopter and reverse any two motor wire connections to the ESC and repeat the motor control test.

Swashplate set to 0° (Neutral)

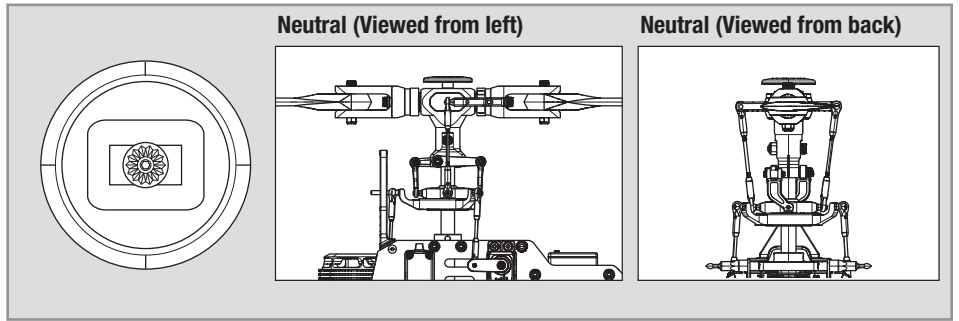

Collective pitch

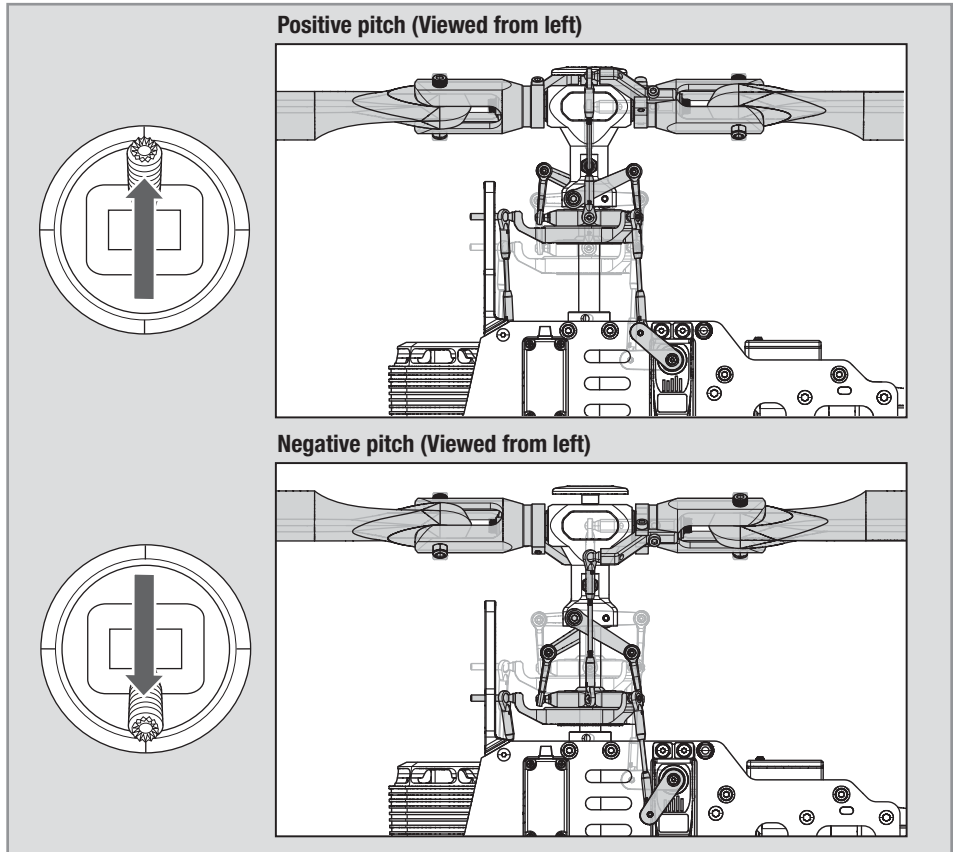
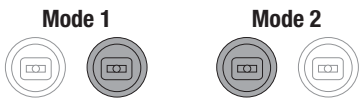

Forward elevator (Viewed from left)

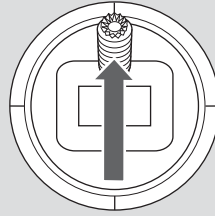
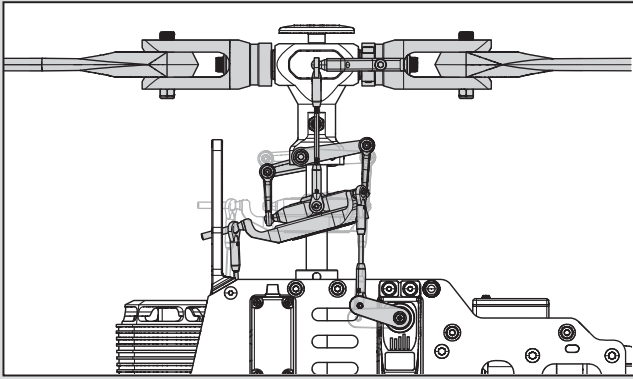

Back elevator (Viewed from left)

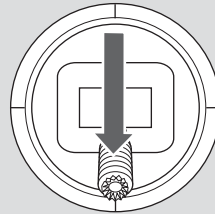
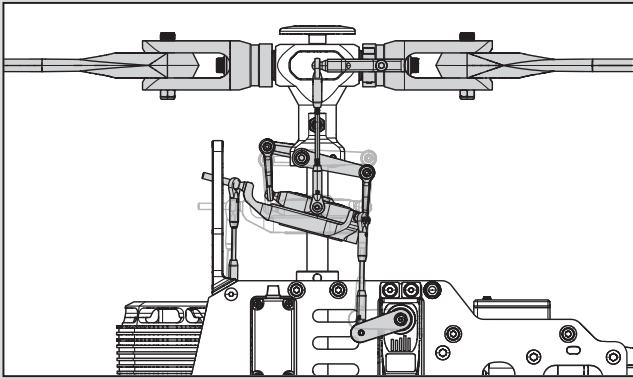

Elevator

Mode 1



Mode 2



Right aileron (Viewed from back)

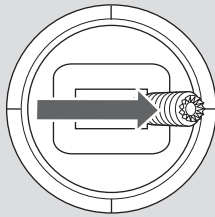
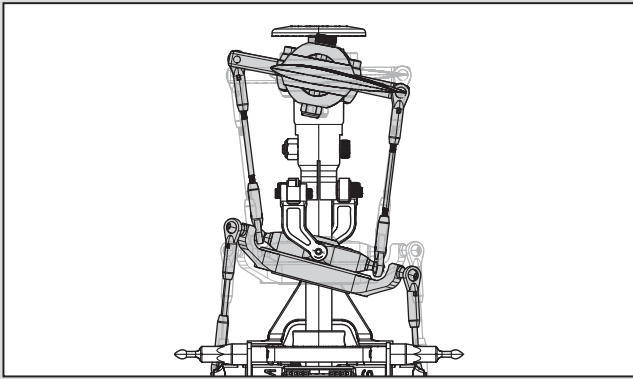

Left aileron (Viewed from back)

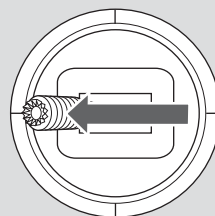
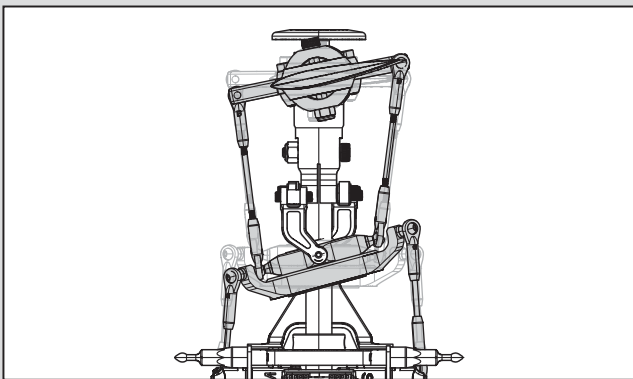

Aileron

Mode 1



Mode 2



## Low Voltage Cutoff (LVC)

Low voltage cutoff (LVC) protects the Li-Po battery from overdischarge in flight and activates when the battery reaches 3V per cell under load.

Set your transmitter timer for 4 minutes and land when the timer expires.

Repeatedly activating LVC damages the flight battery and you will need to replace the battery.

## Flight Guidelines and Warnings

- Always keep aircraft in sight and under control.
- Always keep people and pets at least 45 feet (13 meters) away when the battery is connected.
- Keep children out of the vicinity of this product at all times.
- Always turn on throttle hold at rotor strike.
- Always use fully charged batteries.
- Always keep transmitter powered on while aircraft is powered.
- Always remove batteries before disassembly.
- Always keep moving parts clean.
- Always keep parts dry.
- Always let parts cool after use before touching.
- Always remove batteries after use.
- Always have a first aid kit with you.
- Always have an appropriate fire extinguisher with you.
- Never operate aircraft with damaged wiring.
- Never touch moving parts.

## Flying Your 550X

### Consult local laws and ordinances before choosing a location to fly your aircraft.

Select a large, open area away from people and objects. Your first flights should be outdoors in low-wind conditions. Always stay at least 45 feet (13 meters) away from the helicopter when it is flying.

Do not attempt to fly the Blade 550 X indoors.

**CAUTION:** The Blade 550 X is intended for pilots with experience flying aerobatic, collective pitch helicopters. The Blade 550 X is more responsive than other Blade helicopters. If you are not an experienced 3D or collective pitch helicopter pilot, do not attempt to fly this product.

### Takeoff

Gradually increase the throttle, allowing the rotors time to come up to speed.

**CAUTION:** Do not give any aileron, elevator or rudder commands before the helicopter lifts off. Any control inputs prior to liftoff could cause a crash.

The helicopter will lift off the ground when the rotor head reaches a suitable speed and you apply collective pitch. Once airborne, establish a low-level hover to verify everything is functioning properly. DO NOT use trim to assist in holding the Blade 550X in a desired position. The AR7200BX Flybarless Stabilization System renders trim unnecessary by working to keep the helicopter in whatever attitude you command with the control sticks.

### Flying

This aircraft is extremely sensitive to control inputs. We recommend you fly at low rate settings for the first few flights until you are familiar with its response. For pilots new to collective pitch helicopters, familiarize yourself with your Blade 550 X in normal mode and at low rate.

Crash damage and battery damage are not covered under warranty.

Always disconnect and remove the Li-Po battery from the aircraft after each flight. Charge your Li-Po battery to about half capacity before storage. During storage, make sure battery charge does not fall below 3V per cell. A connected battery will result in trickle discharge.



**CAUTION:** Always fly the helicopter with your back to the sun and wind to prevent loss of flight control.

### Landing

Establish a low level hover. Deliberately lower the throttle until the helicopter lands. Make only small control corrections during this time to avoid rotor blade strikes or other damage.

### When the helicopter is in stunt mode:

- The rotor head speed is constant.
- The main rotor will increase negative pitch as the throttle/collective stick is moved from the middle stick position to the low stick position. Negative pitch allows the helicopter to fly upside down and perform aerobatics.

Change between stunt and normal modes in a hover with the throttle near the hovering stick position.

The helicopter may go up or down when you change between modes due to the difference in the throttle and pitch curves.

**NOTICE:** To minimize damage, always activate throttle hold in preparation for or during a crash.



**WARNING:** Only use Blade 550 X approved carbon fiber main blades. Do not use wooden main blades with the Blade 550 X. Using wooden main blades may cause injury or property damage.

As you become more familiar with the helicopter's response, adjust the rates, expo, pitch and throttle curves to suit your flying style.

## Blade Tracking



**WARNING:** Always maintain a safe distance of at least 15 meters (45 feet) when checking the main rotor blade tracking.

### To check the blade tracking:

1. Put the helicopter in a hover at an altitude near eye height.

2. Watch the movement at the blade tips. Both blades should travel in the same plane.
3. If one blade tip appears to be higher than the other, land the helicopter, disconnect the flight battery and adjust the blade linkages.
4. Repeat Steps 1 through 3 until both blades are moving in the same plane.

## Adjusting the Rudder Gyro Gain

- If the tail wags or oscillates, lower the gain on the gyro.

On your transmitter's gyro menu, decrease the gyro gain values a small amount at a time until the helicopter is stable within a particular flight mode

- If the tail is drifting while hovering, increase the gain on the gyro.

On your transmitter, increase the gyro gain values a small amount at a time until the tail starts to wag/oscillate. Afterwards, reduce the gain until the tail stops wagging/oscillating within a particular flight mode.

## Post-Flight Inspection and Maintenance Checklist

✓		✓	
<b>Ball Links</b>	Make sure the plastic ball link holds the control ball, but is not tight (binding) on the ball. When a link is too loose on the ball, it can separate from the ball during flight and cause a crash. Replace worn ball links before they fail.	<b>Rotors</b>	Make sure there is no damage to rotor blades and other parts which move at high speed. Damage to these parts includes cracks, burrs, chips or scratches. Replace damaged parts before flying.
<b>Cleaning</b>	Make sure the battery is not connected before cleaning. Remove dust and debris with a soft brush or a dry lint-free cloth.	<b>Gyro</b>	Make sure the AR7200BX is securely attached to the frame. Replace the double-sided tape when necessary. The helicopter will crash if the AR7200BX separates from the helicopter frame.
<b>Bearings</b>	Replace bearings when they become notchy (sticky in places when turning) or draggy.	<b>Gearing</b>	Make sure gears are all in good condition. Watch for chipped teeth or excessive wear. White dust around gears is an indication of excess wear. Replace damaged gears before flying.
<b>Wiring</b>	Make sure wiring does not block moving parts. Replace damaged wiring and loose connectors.		
<b>Fasteners</b>	Make sure there are no loose screws, other fasteners or connectors. Do not over tighten metal screws in plastic parts. Tighten screw so parts are mated together, then turn screw only 1/8th of a turn more.		

## AR7200BX Fine-tuning and Adjustment

Observed Behavior	Suggested Adjustment
Cyclic response is too slow or too fast	Adjust end points to fit your flying style. Refer to your transmitter instruction manual for more information
	Adjust the control behavior parameter in the AR7200BX to fit your flying style.
Control inputs feel delayed	Increase Dial 2 on the AR7200BX
The helicopter seems to overshoot control input and then return	Decrease Dial 2 on the AR7200BX
The helicopter tail stops too abruptly	Decrease Dial 3 on the AR7200BX
The helicopter tail does not stop precisely	Increase the rudder gain in your transmitter
	Increase Dial 3 on the AR7200BX
	Adjust the rudder heading lock gain parameter in the AR7200BX

## Blade 550 X Troubleshooting Guide

Problem	Possible Cause	Solution
AR7200BX will not initialize	The helicopter was moved during initialization	Lay the helicopter on its side during initialization if windy
	The transmitter is powered off	Power on the transmitter
	Controls are not centered	Center elevator, aileron and rudder controls. Make sure the throttle is at idle
LED on receiver flashes rapidly and aircraft will not bind to transmitter (during binding)	Transmitter is too near aircraft during binding process	Power off transmitter, move transmitter a larger distance from aircraft, disconnect and reconnect flight battery to aircraft and follow binding instructions
	Bind switch or button was not held while transmitter was powered on	Power off transmitter and repeat bind process
	Aircraft or transmitter is too close to large metal object, wireless source or another transmitter	Move aircraft and transmitter to another location and attempt binding again
LED on receiver flashes rapidly and aircraft will not respond to transmitter (after binding)	Less than a 5-second wait between first powering on transmitter and connecting flight battery to aircraft	Leaving transmitter on, disconnect and reconnect flight battery to aircraft
	Aircraft is bound to a different model memory ( <i>ModelMatch™</i> radios only)	Select correct model memory on transmitter and disconnect and reconnect flight battery to aircraft
	Flight battery/transmitter battery charge is too low	Replace/recharge batteries
	Transmitter may have been bound to a different model (or with a different <i>DSM</i> Protocol)	Select the right transmitter or bind to the new one
	Aircraft or transmitter is too close to large metal object, wireless source or another transmitter	Move aircraft and transmitter to another location and attempt connecting again
Helicopter will not respond to the throttle but responds to other controls	Throttle not at idle and/or throttle trim is too high	Lower the throttle stick and lower the throttle trim
	The transmitter is not in normal mode or throttle hold is on	Make sure the transmitter is in normal mode and throttle hold is off
	The motor is not connected to the ESC or the motor wires are damaged	Connect the motor wires to the ESC and check motor wires for damage
	Flight battery charge is too low	Replace or recharge flight battery
Helicopter power is lacking	Throttle channel is reversed	Reverse the throttle channel on the transmitter
	Flight battery has low voltage	Fully charge the flight battery
	Flight battery is old or damaged	Replace the flight battery
	Flight battery cells are unbalanced	Fully charge the flight battery, allowing the charger time to balance the cells
Helicopter will not lift off	Excessive current is being drawn through the BEC	Check all servos and the helicopter motor for damage
	Main rotor head is not spinning in the correct direction	Make sure the main rotor head is spinning clockwise. Refer to the motor control test
	Transmitter settings are not correct	Check throttle and pitch curve settings and pitch control direction
	Flight battery has low voltage	Fully charge the flight battery
The helicopter tail spins out of control	Main rotor blades are installed backwards	Install the main rotor blades with the thicker side as the leading edge
	Rudder control and/or sensor direction reversed	Make sure the rudder control and the rudder sensor are operating in the correct direction
	Tail servo is damaged	Check the rudder servo for damage and replace if necessary
	Tail drive gears are damaged	Replace damaged gears.
	Inadequate control arm throw	Check the rudder control arm for adequate travel and adjust if necessary
The helicopter wobbles in flight	Torque tube is not fully engaged in tail gears.	Ensure the tail boom and tail gear box are fully seated. Confirm tail pushrod length and tail settings on AR7200BX are correct after making any changes.
	Cyclic gain is too high	Decrease Dial 1 on the AR7200BX
	Head speed is too low	Increase the helicopter's head speed via your transmitter settings and/or using a freshly charged flight pack
	Dampers are worn	Replace the main rotor head dampers

# Limited Warranty

## What this Warranty Covers

Horizon Hobby, Inc. ("Horizon") warrants to the original purchaser that the product purchased (the "Product") will be free from defects in materials and workmanship at the date of purchase.

## What is Not Covered

This warranty is not transferable and does not cover (i) cosmetic damage, (ii) damage due to acts of God, accident, misuse, abuse, negligence, commercial use, or due to improper use, installation, operation or maintenance, (iii) modification of or to any part of the Product, (iv) attempted service by anyone other than a Horizon Hobby authorized service center, (v) Product not purchased from an authorized Horizon dealer, or (vi) Product not compliant with applicable technical regulations.

OTHER THAN THE EXPRESS WARRANTY ABOVE, HORIZON MAKES NO OTHER WARRANTY OR REPRESENTATION, AND HEREBY DISCLAIMS ANY AND ALL IMPLIED WARRANTIES, INCLUDING, WITHOUT LIMITATION, THE IMPLIED WARRANTIES OF NON-INFRINGEMENT, MERCHANTABILITY AND FITNESS FOR A PARTICULAR PURPOSE. THE PURCHASER ACKNOWLEDGES THAT THEY ALONE HAVE DETERMINED THAT THE PRODUCT WILL SUITABLY MEET THE REQUIREMENTS OF THE PURCHASER'S INTENDED USE.

## Purchaser's Remedy

Horizon's sole obligation and purchaser's sole and exclusive remedy shall be that Horizon will, at its option, either (i) service, or (ii) replace, any Product determined by Horizon to be defective. Horizon reserves the right to inspect any and all Product(s) involved in a warranty claim. Service or replacement decisions are at the sole discretion of Horizon. Proof of purchase is required for all warranty claims. SERVICE OR REPLACEMENT AS PROVIDED UNDER THIS WARRANTY IS THE PURCHASER'S SOLE AND EXCLUSIVE REMEDY.

## Limitation of Liability

HORIZON SHALL NOT BE LIABLE FOR SPECIAL, INDIRECT, INCIDENTAL OR CONSEQUENTIAL DAMAGES, LOSS OF PROFITS OR PRODUCTION OR COMMERCIAL LOSS IN ANY WAY, REGARDLESS OF WHETHER SUCH CLAIM IS BASED IN CONTRACT, WARRANTY, TORT, NEGLIGENCE, STRICT LIABILITY OR ANY OTHER THEORY OF LIABILITY, EVEN IF HORIZON HAS BEEN ADVISED OF THE POSSIBILITY OF SUCH DAMAGES. Further, in no event shall the liability of Horizon exceed the individual price of the Product on which liability is asserted. As Horizon has no control over use, setup, final assembly, modification or misuse, no liability shall be assumed nor accepted for any resulting damage or injury. By the act of use, setup or assembly, the user accepts all resulting liability. If you as the purchaser or user are not prepared to accept the liability associated with the use of the Product, purchaser is advised to return the Product immediately in new and unused condition to the place of purchase.

## Law

These terms are governed by Illinois law (without regard to conflict of law principals). This warranty gives you specific legal rights, and you may also have other rights which vary from state to state. Horizon reserves the right to change or modify this warranty at any time without notice.

## WARRANTY SERVICES

### Questions, Assistance, and Services

Your local hobby store and/or place of purchase cannot provide warranty support or service. Once assembly, setup or use of the Product has been started, you must contact your local distributor or Horizon directly. This will enable Horizon to better answer your questions and service you in the event that you may need any assistance. For questions or assistance, please visit our website at [www.horizonhobby.com](http://www.horizonhobby.com), submit a Product Support Inquiry, or call 877.504.0233 toll free to speak to a Product Support representative.

## Inspection or Services

If this Product needs to be inspected or serviced and is compliant in the country you live and use the Product in, please use the Horizon Online Service Request submission process found on our website or call Horizon to obtain a Return Merchandise Authorization (RMA) number. Pack the Product securely using a shipping carton. Please note that original boxes may be included, but are not designed to withstand the rigors of shipping without additional protection. Ship via a carrier that provides tracking and insurance for lost or damaged parcels, as Horizon is not responsible for merchandise until it arrives and is accepted at our facility. An Online Service Request is available at [http://www.horizonhobby.com/content/\\_service-center\\_render-service-center](http://www.horizonhobby.com/content/_service-center_render-service-center). If you do not have internet access, please contact Horizon Product Support to obtain a RMA number along with instructions for submitting your product for service. When calling Horizon, you will be asked to provide your complete name, street address, email address and phone number where you can be reached during business hours. When sending product into Horizon, please include your RMA number, a list of the included items, and a brief summary of the problem. A copy of your original sales receipt must be included for warranty consideration. Be sure your name, address, and RMA number are clearly written on the outside of the shipping carton.

**NOTICE: Do not ship LiPo batteries to Horizon. If you have any issue with a LiPo battery, please contact the appropriate Horizon Product Support office.**

## Warranty Requirements

**For Warranty consideration, you must include your original sales receipt verifying the proof-of-purchase date.** Provided warranty conditions have been met, your Product will be serviced or replaced free of charge. Service or replacement decisions are at the sole discretion of Horizon.

## Non-Warranty Service

**Should your service not be covered by warranty, service will be completed and payment will be required without notification or estimate of the expense unless the expense exceeds 50% of the retail purchase cost.** By submitting the item for service you are agreeing to payment of the service without notification. Service estimates are available upon request. You must include this request with your item submitted for service. Non-warranty service estimates will be billed a minimum of ½ hour of labor. In addition you will be billed for return freight. Horizon accepts money orders and cashier's checks, as well as Visa, MasterCard, American Express, and Discover cards. By submitting any item to Horizon for service, you are agreeing to Horizon's Terms and Conditions found on our website [http://www.horizonhobby.com/content/\\_service-center\\_render-service-center](http://www.horizonhobby.com/content/_service-center_render-service-center).

**ATTENTION: Horizon service is limited to Product compliant in the country of use and ownership. If received, a non-compliant Product will not be serviced. Further, the sender will be responsible for arranging return shipment of the un-serviced Product, through a carrier of the sender's choice and at the sender's expense. Horizon will hold non-compliant Product for a period of 60 days from notification, after which it will be discarded.**

## Warranty and Service Contact Information

Country of Purchase	Horizon Hobby	Address	Phone Number/Email Address
United States of America	Horizon Service Center (Electronics and engines)	4105 Fieldstone Rd Champaign, Illinois 61822 USA	877-504-0233 Online Repair Request: visit <a href="http://www.horizonhobby.com/service">www.horizonhobby.com/service</a>
	Horizon Product Support (All other products)	4105 Fieldstone Rd Champaign, Illinois 61822 USA	877-504-0233 <a href="mailto:productsupport@horizonhobby.com">productsupport@horizonhobby.com</a>
United Kingdom	Horizon Hobby Limited	Units 1-4 Ployters Rd Staple Tye Harlow, Essex CM18 7NS United Kingdom	+44 (0) 1279 641 097 <a href="mailto:sales@horizonhobby.co.uk">sales@horizonhobby.co.uk</a>
Germany	Horizon Technischer Service	Christian-Junge-Straße 1 25337 Elmshorn Germany	+49 (0) 4121 2655 100 <a href="mailto:service@horizonhobby.de">service@horizonhobby.de</a>
France	Horizon Hobby SAS	11 Rue Georges Charpak 77127 Lieusaint, France	+33 (0) 1 60 18 34 90 <a href="mailto:infofrance@horizonhobby.com">infofrance@horizonhobby.com</a>
China	Horizon Hobby – China	Room 506, No. 97 Changshou Rd. Shanghai, China 200060	+86 (021) 5180 9868 <a href="mailto:info@horizonhobby.com.cn">info@horizonhobby.com.cn</a>

## Customer Service Information

Country of Purchase	Horizon Hobby	Address	Phone Number/Email Address
United States of America	Sales	4105 Fieldstone Rd Champaign, Illinois 61822 USA	(800) 338-4639 <a href="mailto:sales@horizonhobby.com">sales@horizonhobby.com</a>
United Kingdom	Horizon Hobby Limited	Units 1-4 Ployters Rd Staple Tye Harlow, Essex CM18 7NS United Kingdom	+44 (0) 1279 641 097 <a href="mailto:sales@horizonhobby.co.uk">sales@horizonhobby.co.uk</a>
Germany	Horizon Hobby GmbH	Christian-Junge-Straße 1 25337 Elmshorn Germany	+49 (0) 4121 2655 100 <a href="mailto:service@horizonhobby.de">service@horizonhobby.de</a>
France	Horizon Hobby SAS	11 Rue Georges Charpak 77127 Lieusaint, France	+33 (0) 1 60 18 34 90 <a href="mailto:infofrance@horizonhobby.com">infofrance@horizonhobby.com</a>
China	Horizon Hobby – China	Room 506, No. 97 Changshou Rd. Shanghai, China 200060	+86 (021) 5180 9868 <a href="mailto:info@horizonhobby.com.cn">info@horizonhobby.com.cn</a>



# Compliance Information for the European Union

---

## Declaration of Conformity

(in accordance with ISO/IEC 17050-1)

No. HH2012101407

Product(s): BLH 550 X Pro Kit

Item Number(s): BLH5525

The object of declaration described above is in conformity with the requirements of the specifications listed below, following the provisions of the European EMC Directive 2004/108/EC:

**EN55022:2010 + AC:2011**

**EN55024:2010**



Signed for and on behalf of:  
Horizon Hobby, Inc.  
Champaign, IL USA  
Oct 14, 2012

Steven A. Hall  
Executive Vice President and Chief Operating Officer  
International Operations and Risk Management  
Horizon Hobby, Inc.

---

## Declaration of Conformity

(in accordance with ISO/IEC 17050-1)

No. HH2012122101

Product(s): Blade 550X Pro Combo

Item Number(s): BLH5525C

The object of declaration described above is in conformity with the requirements of the specifications listed below, following the provisions of the European R&TTE directive 1999/5/EC and EMC Directive 2004/108/EC:

**EN301 489-1 V1.7.1: 2006**

**EN301 489-17 V1.3.2: 2008**

**EN55022:2010 + AC:2011**

**EN55024:2010**



Signed for and on behalf of:  
Horizon Hobby, Inc.  
Champaign, IL USA  
Dec 21, 2012

Steven A. Hall  
Executive Vice President and Chief Operating Officer  
International Operations and Risk Management  
Horizon Hobby, Inc.

---

## Instructions for disposal of WEEE by users in the European Union



This product must not be disposed of with other waste. Instead, it is the user's responsibility to dispose of their waste equipment by handing it over to a designated collection point for the recycling of waste electrical and electronic equipment. The separate collection and recycling of your waste equipment at the time of disposal will help to conserve natural resources and ensure that it is recycled in a manner that protects human health and the environment. For more information about where you can drop off your waste equipment for recycling, please contact your local city office, your household waste disposal service or where you purchased the product.

Exploded View (Head Assembly)/(Rotorkopf)/(Assemblage de la tête)/(Gruppo della testa)

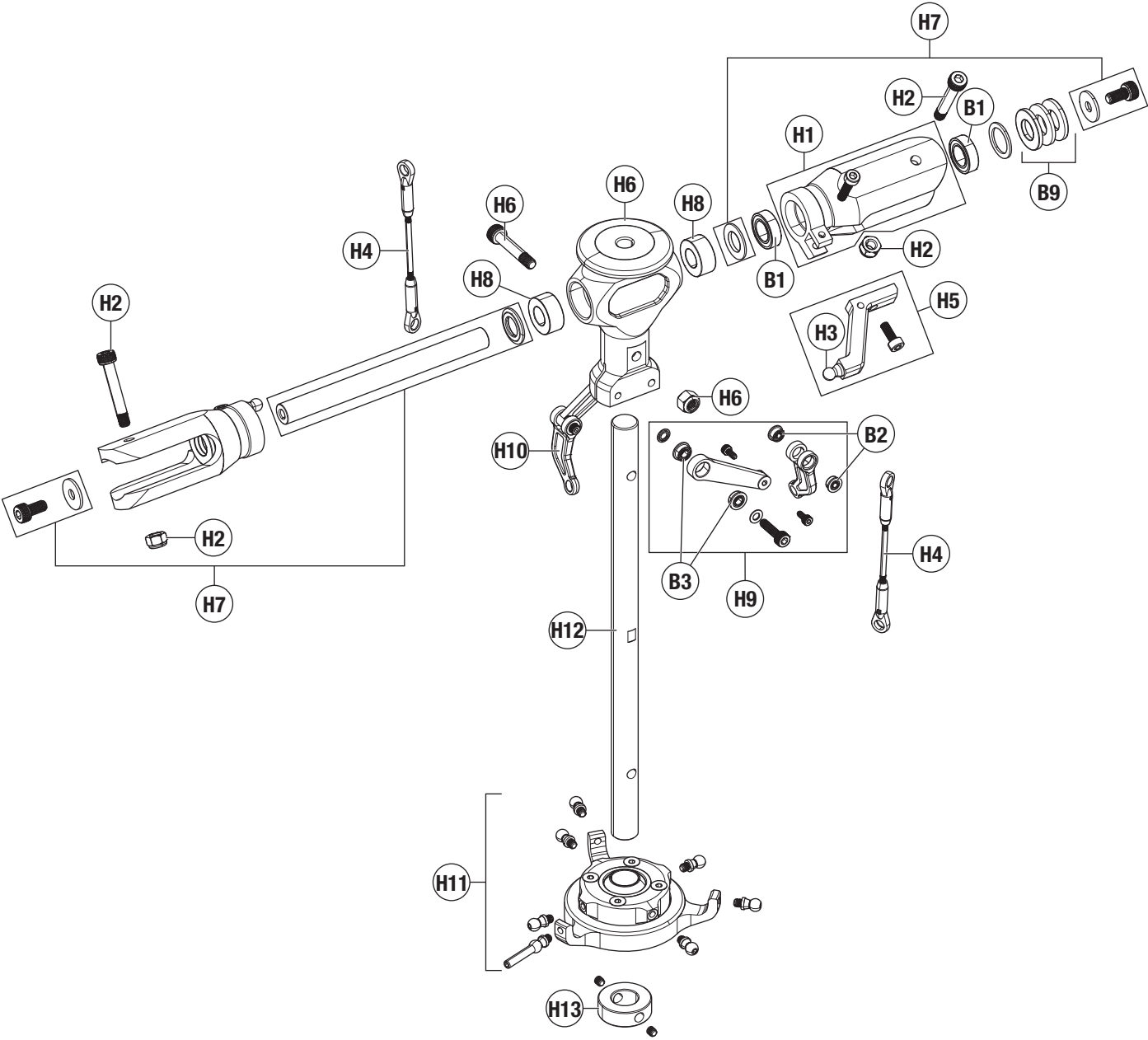

Exploded View (Frame Assembly)/(Chassis)/(Assemblage du châssis)/(Gruppo telaio)

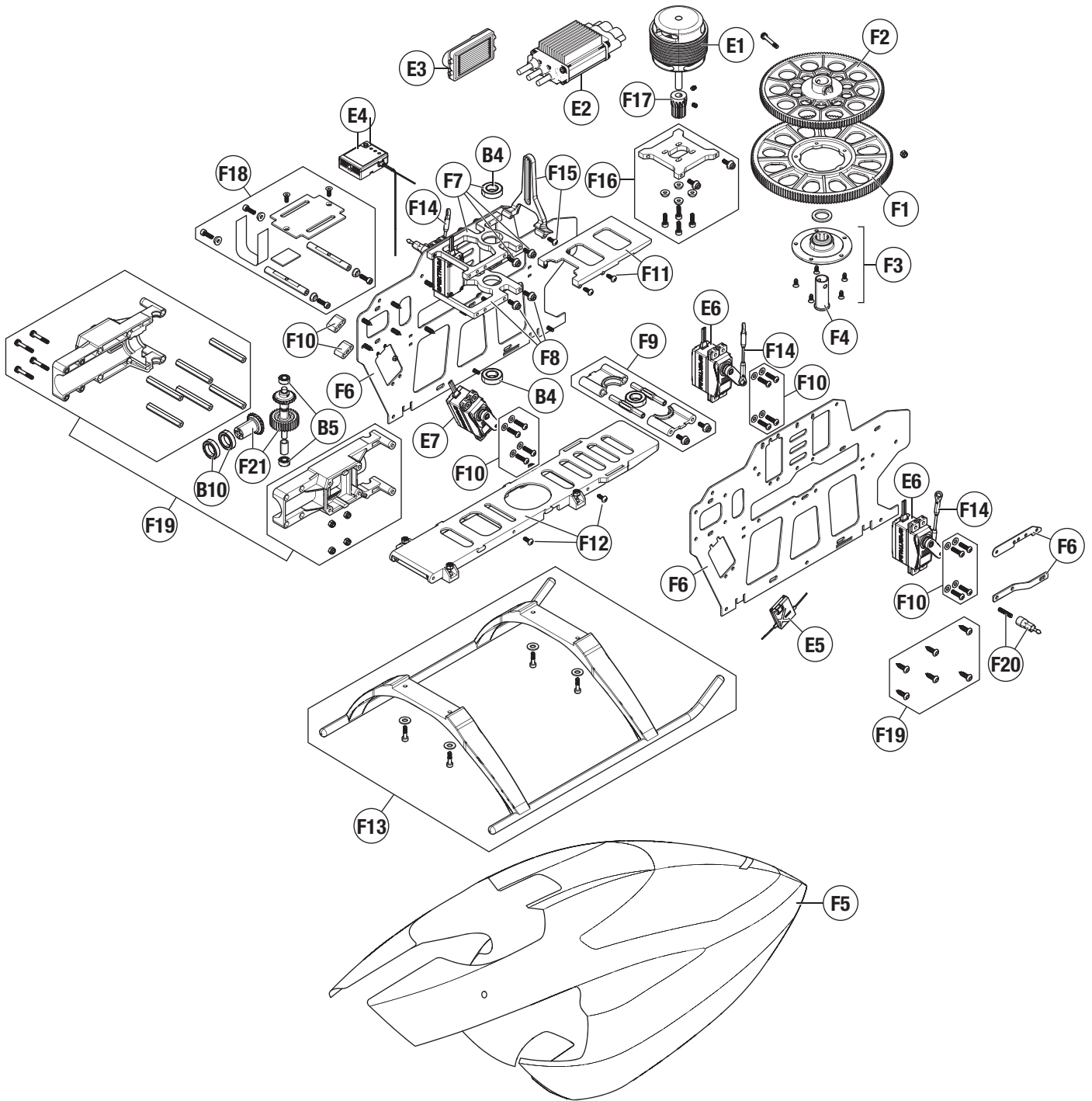

Exploded View (Tail Assembly)/(Heck)/(Assemblage de l'anticouple)/(Gruppo coda)

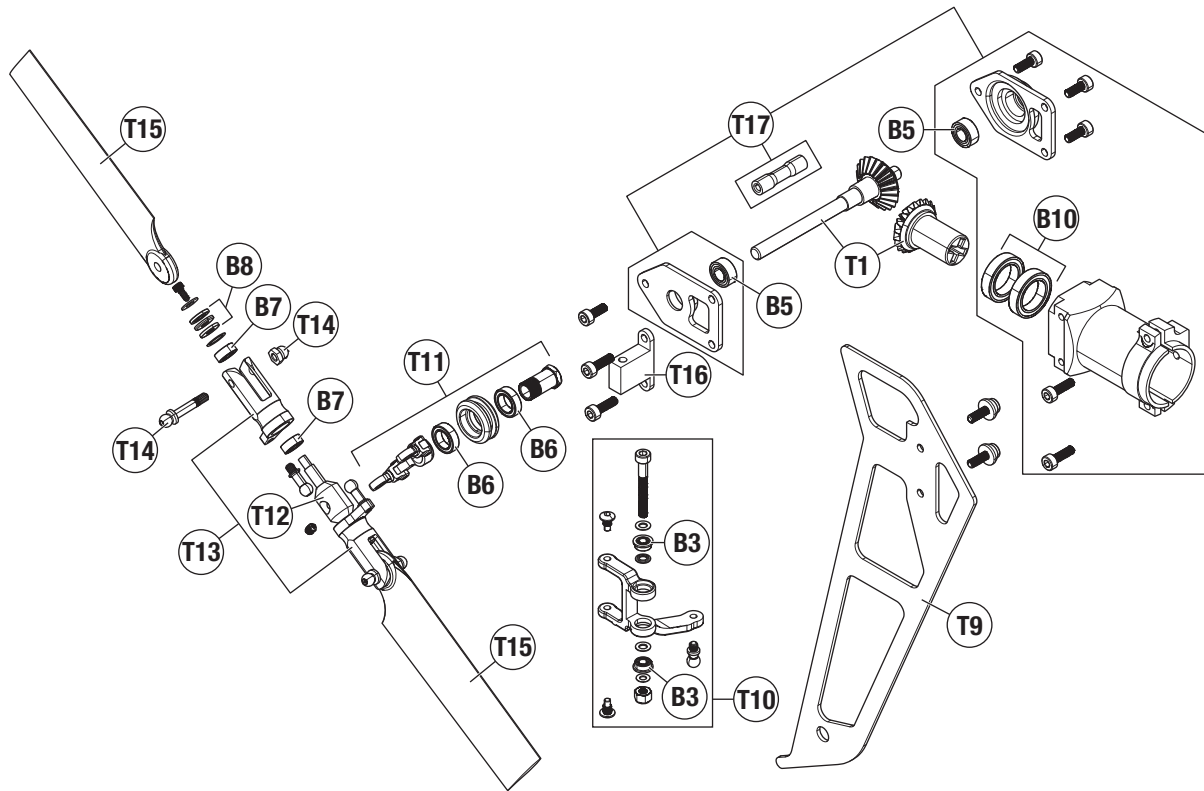

Exploded View (Tailboom Assembly)/(Heckausleger)/(Assemblage de la poutre)/(Gruppo tubo coda)

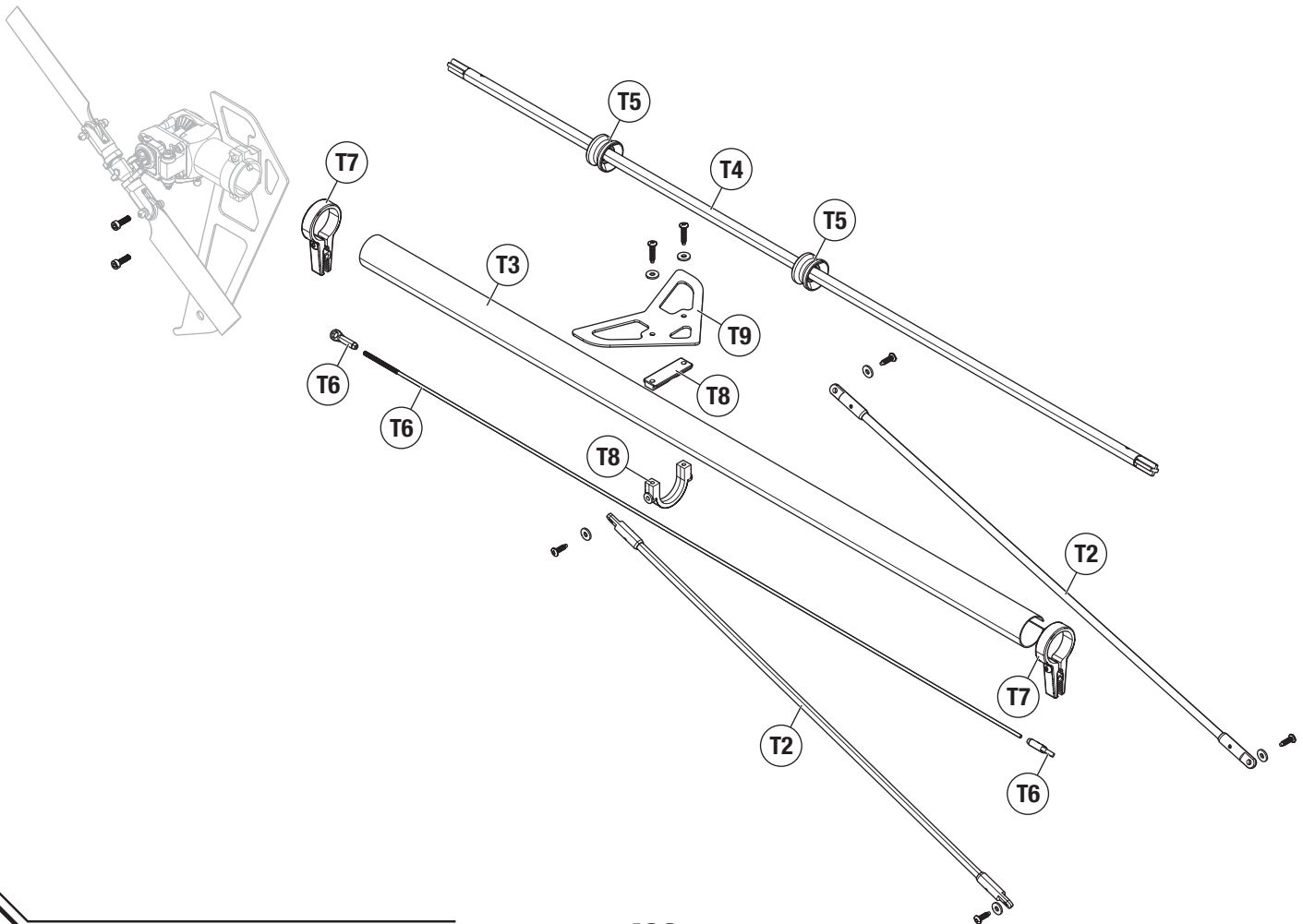

# Parts List / Ersatzteile / Pièces de rechange / Pezzi di ricambio

## Head Explosion/ Explosionszeichnung Rotorkopf / Vue éclatée de la tête/ Vista esplosa della testa

#	Part #	English	Deutsch	Français	Italiano
H1	BLH5501	Fbl Main Rotor Grip Set: 550 X	Blade 550X:Flybarless Rotorblatthalter Set	550 X - Paire de pieds de pales de rotor principal flybarless	Set supporto pale rotore principale Fbl: 550X
H2	BLH5502	Main Rotor Blade Bolt Set (2): 550 X	Blade 550 X: Blatthalterbolzen	550 X - Vis de fixations de pales principales (2)	Set bulloni pale rotore principale (2): 550X
H3	BLH5503	Fbl Main Grip Control Balls: 550 X	Blade 550 X: Kugelkopf Blatthalter	550 X - Rotules de pieds de pales du rotor principal	Set bulloni pale rotore principale: 550X
H4	BLH5504	Fbl Linkage Set: 550 X	Blade 550 X: Flybarless Anlenkungsset	550 X - Biellettes flybarless	Set barrette comandi Fbl: 550 X
H5	BLH5505	Fbl Main Grip Arms: 550 X	Blade 550 X: Flybarless Rotorblatthalterarme Set	550 X - Bras de pieds de pales de rotor principal flybarless	Bracci supporti pale principali Fbl: 550 X
H6	BLH5506	Fbl Aluminum Head Block: 550 X	Blade 550 X: Aluminium Rotorkopfblock	550 X - Moyeu de tête flybarless en aluminium	Bloccaggio testa alluminio Fbl: 550 X
H7	BLH5507	Spindle Set (2): 550 X	Blade 550 X: Blatthalterwelle (2)	550 X - Axe de pied de pales (2)	Set alberino (2): 550 X
H8	BLH5508	Dampers (4): 550 X	Blade 550 X: Dämpfer (4)	550 X - Amortisseurs (4)	Smorzatori (4): 550 X
H9	BLH5509	Fbl Follower Arms: 550 X	Blade 550 X: Taumelscheibenmitnehmer	550 X - Leviers flybarless	Bracci inseguitori Fbl: 550 X
H10	BLH5510	Radius Arms: 550 X	Blade 550 X: Pitchkompensator	550 X - Bras de compensation de pas	Bracci radiali: 550 X
	BLH5511	Servo Control Ball Set: 550 X	Blade 550 X: Servokugelkopfset	550 X - Jeu de rotules pour bras de servo	Set sfere controllo servi: 550 X
H11	BLH5512	Aluminum Swashplate: 550 X	Blade 550 X: Aluminium Taumelscheibe	550 X - Plateau cyclique en aluminium	Piatto oscillante alluminio: 550 X
	BLH5513	Swashplate Ball Set: 550 X	Blade 550 X: Kugelköpfe Taumelscheibe	550 X - Jeu de rotules de plateau cyclique	Set sfere piatto: 550 X
H12	BLH5514	Main Shaft (2): 550 X	Blade 550 X: Hauptrotorwelle	550 X - Axe principal (2)	Albero principale (2): 550 X
H13	BLH5515	Main Shaft Retaining Collar: 550 X	Blade 550 X: Stellring Rotorwelle	550 X - Bague de fixation d'axe principal	Collare di ritenuta albero principale: 550 X
	RVOB055050	Revolution 550mm FBL 3D Carbon Main Blades	Revolution 550mm FBL Carbon Hauptrotorblätter	Revolution Pales en carbone FBL 3D 550mm	Revolution Pale in Carbonio FBL 550 mm

## Main Frame Explosion/Explosionzeichnung Rumpf/Vue éclatée de la cellule principale/Vista esplosa telaio principale

#	Part #	English	Deutsch	Français	Italiano
F1	BLH5516	Main Gear (2): 550 X	Blade 550 X: Hauptzahnrad (2)	550 X - Couronne principale (2)	Ingranaggio principale (2): 550 X
F2	BLH5517	Autorotation Gear (2): 550 X	Blade 550 X: Zahnrad Freilauf	550 X - Couronne d'autorotation (2)	Ingranaggio autorotazione (2): 550 X
F3	BLH5518	One-Way Bearing Hub w/One way bearing: 550 X	Blade 550 X: Freilauflager	550 X - Roue libre avec moyeu	Mozzo e cuscinetto ruota libera: 550 X
F4	BLH5519	One-Way Bearing Shaft and Shim Set: 550 X	Blade 550 X: Freilauf mit Unterlegscheibe	550 X - Axe de roue libre avec rondelle de calage	Set albero cuscinetto ruota libera e rasamento: 550 X
F5	BLH5520	Canopy: 550 X	Blade 550 X: Haube	550 X - Bulle verte d'origine	Capottina: 550 X
F6	BLH5521	CF Main Frame Set: 550 X	Blade 550 X: Chassis Set	550 X - Jeu de flancs de châssis en carbone	Set telaio principale CF: 550 X
F7	BLH5522	Upper Bearing Block: 550 X	Blade 550 X: Lagerblock oben	550 X - Support de roulement supérieur	Blocco cuscinetto superiore: 550 X
F8	BLH5523	Middle Bearing Block: 550 X	Blade 550 X: Lagerblock mitte	550 X - Support de roulement médian	Blocco cuscinetto centrale: 550 X
F9	BLH5524	Lower Bearing Block: 550 X	Blade 550 X: Lagerblock unten	550 X - Support de roulement inférieur	Blocco cuscinetto inferiore: 550 X
F10	BLH5526	Servo Screw Set: 550 X	Blade 550 X: Servoschraubenset	550 X - Jeu de vis de servos	Set viti servi: 550 X
F11	BLH5527	ESC Mounting Tray: 550 X	Blade 550 X: Reglermontageplatte	550 X - Platine de fixation du contrôleur	Supporto montaggio ESC: 550 X
F12	BLH5528	Bottom Plate: 550 X	Blade 550 X: Bodenplatte	550 X - Platine inférieure	Piastra inferiore: 550 X
F13	BLH5529	Landing Gear (2): 550 X	Blade 550 X: Kufengestell	550 X - Train d'atterrissage (2)	Carrello atterraggio (2): 550 X
F14	BLH5530	Linkage Set: 550 X	Blade 550 X: Gestängenset	550 X - Jeu de tringleries	Set astine comandi: 550 X
F15	BLH5531	Anti-Rotation Bracket: 550 X	Blade 550 X: Taumelscheibenführung	550 X - Support anti-rotation	Staffa antirotazione: 550 X

## Main Frame Explosion/Explosionszeichnung (Chassis)/Vue éclatée de la cellule principale/Esploso telaio principale

#	Part #	English	Deutsch	Français	Italiano
F16	BLH5532	Motor Mount: 550 X	Blade 550 X: Motorhalter	550 X - Support moteur, 3X25mm	Supporto motore: 550 X
F17	BLH5533	Pinion 14T: 550 X	Blade 550 X: Ritzel 14 Zähne	550 X - Pignon 14T	Pignone: 550 X
F18	BLH5534	Fbl Unit Mount: 550 X	Blade 550 X: Halter f. Flybarless Kontroll Einheit	550 X - Support d'unité flybarless	Unità montaggio Fbl: 550 X
F19	BLH5535	Tail Boom Case: 550 X	Blade 550 X: Heckrotorgehäuse	Boîtier d'anticouple	Scatola tubo coda: 550 X
F20	BLH5536	Canopy Posts: 550 X	Blade 550 X: Haubenhalter	550 X - Support de bulle	Supporti capottina: 550 X
F21	BLH5537	Front Tail Gear Set: 550 X	Blade 550 X: Getriebeset vorne	550 X - Jeu de pignons avant d'anticouple	Set ingranaggio anter. coda: 550 X

## Tail Explosion/Explosionzeichnung Heck / Vue éclatée de la queue/Vista esplosa della coda

#	Part #	English	Deutsch	Français	Italiano
T1	BLH5538	Rear Tail Gear Set: 550 X	Blade 550 X: Heckgetriebe	550 X - Jeu de pignons arrière d'anticouple	Set ingranaggi poster. coda: 550 X
T2	BLH5539	Boom Support Set: 550 X	Blade 550 X: Heckrohrhalter	550 X - Jeu de supports de poutre	Set supporti tubo coda: 550 X
T3	BLH5540	Boom (2): 550 X	Blade 550 X: Heckrohr	550 X - Poutre (2)	Tubo coda (2): 550 X
T4	BLH5541	Torque Tube Assembly: 550 X	Blade 550 X: Heckwelle Führungsrohr	550 X - Torque tube complet	Gruppo barra di torsione: 550 X
T5	BLH5542	Torque Tube Holder: 550 X	Blade 550 X: Halter f. Heckwelle	550 X - Support de torque tube	Fissaggio barra di torsione: 550 X
T6	BLH5543	Tail Pushrod Set (2): 550 X	Blade 550 X: Gestängeset Heck	550 X - Jeu de commande d'anticouple (2)	Set comando coda (2): 550 X
T7	BLH5544	Tail Pushrod Guide Set: 550 X	Blade 550 X: Führung Heckgestänge	550 X - Jeu de guide de commande d'anticouple	Set guida comando coda: 550 X
T8	BLH5545	Horizontal Fin Mount: 550 X	Blade 550 X: Halter Horizontalfinne	550 X - Support de stabilisateur	Supporto impennaggio orizzontale: 550 X
T9	BLH5546	Fin Set: 550 X	Blade 550 X: Finnenset	550 X - Empennages	Set impennaggio: 550 X
T10	BLH5547	Tail Rotor Pitch Lever Set: 550 X	Blade 550 X: Heckrotorpitchhebelset	550 X - Set de leviers d'anticouple	Set leve passo rotore coda: 550 X
T11	BLH5548	Tail rotor Pitch Control Slider Set: 550 X	Blade 550 X: Schiebehülse Heckrotor Set	550 X - Coulisseau d'anticouple	Set cursore controllo passo coda: 550 X
T12	BLH5549	Tail Rotor Hub: 550 X	Blade 550 X: Heckrotorzentralstück	550 X - Moyeu de rotor d'anticouple	Alberino rotore coda: 550 X
T13	BLH5550	Tail Rotor Blade Grip/Holder Set: 550 X	Blade 550 X: Heckrotorblatthalter	550 X - Jeu de pieds de pales d'anticouple	Set portapale rotore coda: 550 X
T14	BLH5551	Tail Rotor Grip Bolt Set: 550 X	Blade 550 X: Heckrotorblatthalterbolzenset	550 X - Set de visserie de pieds de pales d'anticouple	Set bulloni portapale coda: 550 X
T15	BLH5552	Tail Rotor Blade Set: 550 X	Blade 550 X: Heckrotorblätter Set	550 X - Paire de pales d'anticouple	Set pale di coda: 550 X
T16	BLH5553	Tail Bellcrank Mount: 550 X	Blade 550 X: Halter für Heckrotorpitchhebel	550 X - Support de renvois d'anticouple	Supporto squadrette coda: 550 X
T17	BLH5554	Tail Case Set: 550 X	Blade 550 X: Leitwerkshalter	550 X - Boîtier d'anticouple	Set scatola coda: 550 X

## Bearings / Lager / Roulements à billes / Cuscinetti

#	Part #	English	Deutsch	Français	Italiano
B1	BLH1842	8x14x4mm Radial Bearings	Blade 8x14x4mm Radiallager	Roulement 8x14x4mm	8x14x4mm Cuscinetto radiale
B2	BLH1809	2x5x2.5mm Flanged Bearings	Blade 2x5x2.5mm Bundlager	Roulement 2x5x2.5mm	2x5x2.5mm Cuscinetto flangiato
B3	BLH5555	3x6x2.5mm Flanged Bearings	Blade 3x6x2.5mm Bundlager	Roulement 3x6x2.5mm	3x6x2.5mm Cuscinetto flangiato
B4	BLH5556	10x19x5mm Radial Bearing	Blade 10x19x5mm Radiallager	Roulement 10x19x5mm	10x19x5mm Cuscinetto radiale
B5	BLH1642	5x10x4mm Radial Bearing	Blade 5x10x4mm Radiallager	Roulement 5x10x4mm	5x10x4mm Cuscinetto radiale
B6	BLH5557	7x11x3mm Radial Bearing	Blade 7x11x3mm Radiallager	Roulement 7x11x3mm	7x11x3mm Cuscinetto radiale
B7	BLH5558	5x9x3mm Radial Bearing	Blade 5x9x3mm Radiallager	Roulement 5x9x3mm	5x9x3mm Cuscinetto radiale
B8	BLH5559	4x9x4mm Thrust Bearing	Blade 4x9x4mm Drucklager	Butée à billes 4x9x4mm	4x9x4mm Cuscinetto reggispinta
B9	BLH5560	8x16x5mm Thrust Bearing	Blade 8x16x5mm Drucklager	Butée à billes 8x16x5mm	8x16x5mm Cuscinetto reggispinta
B10	BLH5561	12x18x4mm Radial Bearing	Blade 12x18x4mm Radiallager	Roulement 12x18x4mm	12x18x4mm Cuscinetto radiale

## Electronic Parts/Elektronische Komponenten/Composants électroniques/Parti Elettroniche

#	Part #	English	Deutsch	Français	Italiano
E1	EFLM60550A	Heli 550 Brushless Outrunner Motor, 1360Kv	Heli 550 Brusless Außenläufer Motor 1360Kv	Moteur Brushless 550 à cage tournante 1360Kv	Motore Outrunner per elicottero 550 da 1360 Kv
E2	EFL3130H	130-Amp Heli Brushless ESC: 550X	550X 130 A Heli Brushless Regler	Contrôleur brushless héli 130A	Regolatore di Giri da 130 Amp Brushless
E3	EFLA410	10-Amp BEC: 550 X	550X 10A BEC	10-Amp BEC: 550 X	BEC da 10 Amp
E4	SPMAR7200BX	AR7200BX 7CH DSMX Flybarless Control System	AR7200BX 7- Kanal DSMX Flybaless Control System	Module de commande flybarless AR7200BX 7 voies DSMX	Ricevente Flybarless AR7200BX 7 Canali DSMX
E5	SPM9645	DSMX Remote Receiver	DSMX Satellitenempfänger	Récepteur satellite DSMX	Ricevente Remota DMSX
E6	SPMSH6040	H6040 Digital Heli Servo - High Speed	Blade 550 X: H6040 Digital Heli Servo-High Speed	Servo digital héli haute vitesse H6040	H6040 Servo digitale alta velocità
E7	SPMSH6080G	H6080G Gyro Servo	Blade 550 X: H6080G Gyro Servo	Servo pour gyro H6080G	H6080G Gyro Servo
	BLH5564	Servo Arm Set: 550 X	Blade 550 X: Servoarmset	550 X - Jeu de bras de servos	Set bracci servi: 550 X

## Miscellaneous / Verschiedenes / Divers / Varie

#	Part #	English	Deutsch	Français	Italiano
	BLH5563	Hook and Loop Battery Strap: 550 X	Blade 550 X: Klettband	550 X - Sangle de batterie	Nastro a strappo: 550 X
	BLH5565	Helicopter Main Blade Holder: 550 X	Blade 550 X: Blatthalter	550 X - Support de pales principales	Supporto pale principali: 550 X

## Optional Parts / Optionale Bauteile / Pièces optionnelles / Pezzi opzionali

Part #	English	Deutsch	Français	Italiano
BLH5520GR	Green Option Canopy: 550 X	Blade 550 X: Kabinenhaube	550 X - Bulle verte option	Capottina opzionale verde: 550 X
BLH5520R	Red Option Canopy: 550 X	Blade 550 X: optional Haube Rot	550 X - Bulle rouge option	Capottina opzionale rosso: 550 X
BLH5529BL	Black Landing Gear: 550 X	Blade 550 X: Kufengestell schwarz	550 X - Train d'atterrissage noir	Carrello atterraggio nero: 550 X
RVOT008500	Revolution 85mm CF 3D TR Blades*	Revolution 85mm Carbon 3D Heckrotorblätter*	Pales d'anticouple Révolution 3D en carbone 85mm*	Pale REVOLUTION da 85mm CF TR*
EFLC3020	Celectra 200W DC Multi-Chemistry Battery Charger	E-flite 200W DC Multi-Batterie Ladegerät	Chargeur de batterie multi-types CC Celectra 200 W	Celectra 200W DC caricabatteria multichimico
EFLC3025	Celectra 80W AC/DC Multi-Chemistry Battery Charger	E-flite 80W AC/DC Multi-Batterie Ladegerät - EU	Chargeur de batterie multi-types CA/CC Celectra 80 W	Caricabatterie per batteria multichimica 80 W CA/CC
EFLC4005	12VDC, 120W Power Supply	E-flite 12VDC 120W Netzgerät	Alimentation 12 V CC, 120 W	12VCC, 120W alimentatore
	DX8 DSMX Transmitter Only	Spektrum DX8 DSMX Sender	Émetteur DSMX DX8 seul	Solo trasmettitore DSMX DX8
	DX6i DSMX Transmitter Only	Spektrum DX6i DSMX Nur Sender	Émetteur DSMX DX6i seul	DX6i DSMX Solo trasmettitore
	DX7s Transmitter Only	Spektrum DX7s nur Sender	Émetteur DX7s seul	DX7s Solo trasmettitore
	DX18 Transmitter Only	Spektrum DX18 nur Sender	Émetteur DX18 seul	DX18 Solo trasmettitore

\*Use of carbon fiber tail blades may require reduced gain on the tail.

\*Die Verwendung von Carbon Heckrotorblättern kann einen reduzierten Gainanteil am Heck erfordern.

\*Il sera peut-être nécessaire de réduire le gain à l'anticouple en cas d'utilisation de pales d'anticouple en fibre de carbone.

\*L'uso di pale di coda in carbonio potrebbe richiedere la riduzione della sensibilità della coda.

©2012 Horizon Hobby, Inc.

Blade, E-flite, Dynamite, Revolution, EC5, Celectra, DSM, DSM2, DSMX, AirWare, ModelMatch and the Horizon Hobby logo are trademarks or registered trademarks of Horizon Hobby, Inc.

The Spektrum trademark is used with permission of Bachmann Industries, Inc.

BeastX is a trademark of Markus Schaack and is used with permission.

The Spektrum AR7200BX employs technology exclusively licensed to Horizon Hobby, Inc. from freakware GmbH.

Created 7/12 35495