

BLADE[®]

MX2

Instruction Manual



Table of Contents

Troubleshooting	2
Specifications	3
Warning	3
Additional Safety Precautions and Warnings	3
Blade mCX2 RTF Contents	4
Blade mCX2 BNF Contents	4
First Flight Preparation	5
Flying Checklist	5
Battery Warnings and Guidelines	6
Battery Charging	8
Installing the Transmitter Batteries (RTF ONLY)	9
Installing the Flight Battery	9
Transmitter and Receiver Binding	10
Transmitter Control Identification	12
Control Test	13
Channel 5 Information	15
5-in-1 Control Unit Description, Arming and Motor Control Test	16
Understanding the Primary Flight Controls	18
Dual Rates	21
Choosing a Flying Area	21
Flying the Blade mCX2	22
Advanced Swash Plate Settings	23
Exploded View Parts Listing	24
Exploded View	25
Replacement Parts List	26
Option Parts	26
Warranty	28
Compliance Information for the European Union	30

Troubleshooting

If you encounter any difficulties while charging, setting up, testing functions or flying your Blade mCX2, see page 30 to contact the appropriate Horizon Product Support office.

Specifications

Length	7.9 in (200mm)
Height	4.7 in (120mm)
Main Rotor Diameter	7.5 in (190mm)
Weight with Battery	1.0 oz (28 g)
Main Motors	Micro coreless (2 installed)
Battery	1-Cell 3.7V 120mAh LiPo (included)
Charger	1-Cell 3.7V DC LiPo (included)
Transmitter	MLP4DSM 2.4GHz DSM 4-channel (RTF Only)
On-Board Electronics	5-in-1 receiver/servos/mixer/ESCs/gyro (installed)

Warning

An RC helicopter is not a toy! If misused, it can cause serious bodily harm and damage to property. Fly only in open areas, preferably at AMA (Academy of Model Aeronautics) approved flying sites, following all instructions.

Keep items that can get entangled in the rotor blades away from the main and tail blades, including loose clothing, pencils and screwdrivers. Especially keep your hands away from the rotor blades.

Additional Safety Precautions and Warnings

As the user of this product, you are solely responsible for operating it in a manner that does not endanger yourself and others or result in damage to the product or the property of others.

This model is controlled by a radio signal that is subject to interference from many sources outside your control. This interference can cause momentary loss of control so it is advisable to always keep a safe distance in all directions around your model, as this margin will help to avoid collisions or injury.

- Never operate your model with low transmitter batteries.
- Always operate your model in an open area away from cars, traffic or people.
- Avoid operating your model in the street where injury or damage can occur.
- Never operate the model out into the street or populated areas for any reason.
- Carefully follow the directions and warnings for this and any optional support equipment (chargers, rechargeable battery packs, etc.).
- Keep all chemicals, small parts and anything electrical out of the reach of children.
- Moisture causes damage to electronics. Avoid water exposure to all equipment not specifically designed and protected for this purpose.
- Never lick or place any portion of your model in your mouth as it could cause serious injury or even death.

Blade® mCX2 RTF Contents

Item	Description
Not Available Separately	Blade mCX2 RTF Airframe
EFLH1064B	MLP4DSM 4-Channel Transmitter, 2.4GHz DSM2
EFLB1201S	120mAh 1-Cell 3.7V Li-Po
EFLC1000	1-Cell 3.7V Li-Po Charger, 0.3A
EFLH1209	Screwdriver
Not Available Separately	8 AA Batteries
(Optional) FUG4	4 AA Batteries



Blade mCX2 BNF Contents

Item	Description
Not Available Separately	Blade mCX2 RTF Airframe
EFLB1201S	120mAh 1-Cell 3.7V Li-Po
EFLC1000	1-Cell 3.7V Li-Po Charger, 0.3A
EFLH1209	Screwdriver
Not Available Separately	4 AA Batteries
(Optional) FUG4	4 AA Batteries



Note: These checklists are not intended to be a replacement for the content included in this instruction manual. Although they can be used as a quick start guide, we strongly suggest reading through this manual completely before proceeding.

First Flight Preparation

- Remove and inspect contents
- Install four of the included AA batteries in the charger
- Begin charging the flight battery
- Install the remaining four AA batteries in the transmitter (RTF ONLY)
- Install the flight battery in the helicopter (once it has been fully charged)
- Test the controls
- Familiarize yourself with the controls
- Find a suitable area for flying

Flying Checklist

- Always turn the transmitter on first
- Plug the flight battery into the lead from the 5-in-1 control unit
- Allow the 5-in-1 control unit to initialize and arm properly
- Fly the model
- Land the model
- Unplug the flight battery from the 5-in-1 control unit
- Always turn the transmitter off last

Battery Warnings and Guidelines

The 1S 3.7V DC Lithium Polymer Battery Charger (PKZ3240) included with the Blade mCX2 has been specifically designed to safely charge the included 150mAh 3.7V 14C Li-Po battery. You may also use the E-flite® Celectra™ 4-Port Charger (EFLC1004). You must read the following safety instructions and warnings before handling, charging or using the Li-Po battery.

⚠ CAUTION: Li-Po batteries are significantly more volatile than the alkaline, Ni-Cd or Ni-MH batteries used in RC applications. All instructions and warnings must be followed exactly. Mishandling of Li-Po batteries can result in a fire, personal injury, and/or property damage.

- By handling, charging or using the included Li-Po battery you assume all risks associated with lithium batteries. If you do not agree with these conditions, return your complete Blade mCX2 model in new, unused condition to the place of purchase immediately.
- You must charge the included Li-Po battery in a safe area away from flammable materials.
- Never charge the battery unattended. When charging the battery you should always remain in constant observation to monitor the charging process and react to potential problems that may occur.
- After flight, the battery must be cooled to ambient temperature before charging.
- **DO NOT USE A Ni-Cd OR Ni-MH CHARGER. Failure to charge the battery with a compatible charger may cause fire resulting in personal injury and/or property damage.**



- If at any time during the charge or discharge process the battery begins to balloon or swell, discontinue charging or discharging immediately. Quickly and safely disconnect the battery, then place it in a safe, open area away from flammable materials to observe it for at least 15 minutes. Continuing to charge or discharge a battery that has begun to balloon or swell can result in a fire. A battery that has ballooned or swollen even a small amount must be removed from service completely.
- Store the battery at room temperature in a dry area for best results.

- When transporting or temporarily storing the battery, the temperature range should be from 40–120° F. Do not store the battery or model in a car or direct sunlight whenever possible. If stored in a hot car, the battery can be damaged or even catch fire.
- Do not over-discharge the Li-Po flight battery. Discharging the battery too low can cause damage to the battery resulting in reduced power, duration or failure of the battery entirely.

Li-Po cells should not be discharged to below 3V each under load. In the case of the Li-Po battery used for the Blade mCX2, do not allow the battery to fall below 3V during flight.

The Blade mCX2's 5-in-1 control unit features a soft low voltage cutoff (LVC) that occurs when the battery reaches 3V under load. When the soft cutoff occurs, the ESCs of the 5-in-1 unit reduce power to the motors (regardless of the power level set with the throttle stick) in order to prevent the voltage of the battery from dropping below 3V. This power reduction usually requires you to land the model immediately, at which point you should power down the model and unplug the flight battery.

And while it is possible to power the model up and to fly again after the soft LVC occurs, this is NOT recommended as continued discharging to the soft LVC will cause permanent damage to the Li-Po battery resulting in lost power and duration in subsequent flights, or failure of the battery entirely. Continued attempts to further discharge the battery may also result in loss of control while the motors are running as the voltage may drop below the minimum operating voltage of the receiver and other electronics.

Also, it is not recommended that you fly to the soft LVC every time you fly. Instead, be aware of the power level of the battery/helicopter throughout the flight, and if at any time the helicopter begins to require more throttle than typical to maintain hover or flight, land the helicopter immediately. Routinely discharging the battery to the soft LVC can still cause permanent damage to the battery.

Note: When the battery power/voltage is getting low, you will typically find that significant rudder trim and/or rudder stick adjustments are needed to prevent the helicopter from spinning. This usually occurs before soft LVC, and indicates a good time to stop flying.

Battery Charging

Follow these steps to charge the Li-Po battery with the included charger:

- Remove the cover on the bottom of the charger and install four of the included AA batteries, noting proper polarity. Replace the cover after the AA batteries are installed.
- Slide the battery into the slot on the charger. The endcap of the battery has been specifically designed to allow the battery to be slid into the slot easily one way (usually with the label on the battery facing outward) to prevent reverse polarity connection. However, check for proper alignment and polarity before proceeding to the next step.



- Gently press the battery and its connector into the charge jack/connector located at the bottom of the slot on the charger.
- Once the connection is successful, the LED light on the charger turns solid red, indicating charging has begun.
- A fully discharged battery (not over-discharged) takes approximately 30–40 minutes to charge. As the battery nears full charge, the LED light will blink. When the battery is fully charged the LED light blinks approximately every 20 seconds or goes out entirely.

Note: The Li-Po battery included with your Blade mCX2 will arrive partially charged. For this reason the initial charge may only take 15–20 minutes.

Note: You can expect to charge the Li-Po flight battery approximately 15–20 times before it will be necessary to replace the AA batteries in the charger.

An optional 6V power supply is also available separately (EFLC1005). This power supply will allow you to charge at home without the need for AA batteries.

Installing the Transmitter Batteries (RTF ONLY)

Install four of the included AA batteries in the transmitter. Check for proper operation of the transmitter by switching the power switch on (to the left). The LED light at the top of the transmitter should begin to glow solid red while the transmitter beeps.



Installing the Flight Battery

Once the Li-Po battery is fully charged, you can install it in the helicopter.

This is done by sliding it into the battery mounting supports/slots just below the main gears. Slide the battery into the slots with the label facing downward and the connector oriented toward the back of the helicopter.

Note: Be sure to slide the battery into the slots until the endcap of the battery comes into contact with the rear battery support. This allows you to achieve the correct center of gravity for the best overall flight performance. However, be sure the battery is not pushed far enough forward that it makes contact with the servo gears, as this could cause damage to the gears and a potential crash.



Transmitter and Receiver Binding

The Blade mCX2 RTF comes bound to the MLP4DSM transmitter included.

The BNF version requires you to bind to your own compatible DSM2 Aircraft Transmitter.

To bind or re-bind your mCX2 to your chosen transmitter please follow the directions below:

Binding is the process of programming the receiver of the control unit to recognize the GUID (Globally Unique Identifier) code of a single specific transmitter. You need to 'bind' your chosen Spektrum DSM2 technology equipped aircraft transmitter to the receiver for proper operation.

Following are some of the Spektrum DSM2-equipped transmitters and modules that bind to the receiver of your Blade mCX2.

E-flite MLP4DSM	E-flite LP5DSM
ParkZone Vapor Transmitter	PKZ Ember 2 Transmitter
JR 12X 2.4	JR X9303 2.4
Spektrum DX5e	Spektrum DX6i
Spektrum DX7/DX7se	

Note: The Spektrum DX6 (SPM2460) is equipped with DSM (not DSM2) technology and is not compatible with the receiver of the Blade mCX2.

The following steps outline the binding process:

- Make sure the flight battery is disconnected from the 5-in-1 unit and the transmitter is turned off.
- Plug the flight battery into the 5-in-1 unit.
- Plug the flight battery into the 5-in-1 unit. After 5 seconds the LED on the 5-in-1 unit will begin flashing.

MLP4DSM and ParkZone Vapor/Ember 2 Transmitters

After verifying the LED is flashing on the receiver/5-in-1, PUSH directly down on the left-hand stick while switching the transmitter on (you will feel a 'click' when you push in on the end of the stick).



After approximately 5–10 seconds the receiver/5-in-1 should be bound to the transmitter and you should now have full control and function.

LP5DSM

If you decide to use an E-flite LP5DSM transmitter, please position your channel reversal dip switches as follows.

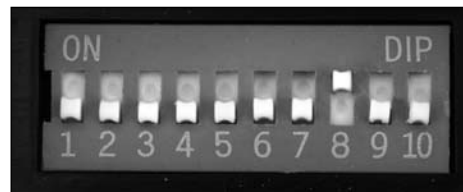

1. Plug the flight battery into the 5-in-1 unit. After 5 seconds the LED on the 5-in-1 unit will begin flashing.
2. Move the sticks and switches on the transmitter to the desired failsafe positions (low throttle and neutral control positions).
3. Turn the transmitter on. The red LED located under the door on the bottom left front of the transmitter will blink rapidly.

DX5e and DX6i

1. Move the sticks and switches on the transmitter to the desired failsafe positions (low throttle and neutral control positions).
2. For the DX5e: Pull and hold the Trainer Switch on the transmitter while turning the transmitter on. Release the trainer switch once the LEDs on the front of the transmitter flash.
3. For the DX6i: Pull and hold the Trainer Switch on the transmitter while turning the transmitter on. Release the trainer switch once "BIND" Flashes on the LCD screen of the transmitter.
4. After approximately 5–10 seconds the receiver/5-in-1 should be bound to the transmitter and you should have full control and function.

DX7, DX7se, X9303, or 12X:

1. Move the sticks and switches on the transmitter to the desired failsafe positions (low throttle and neutral control positions)
2. Press the bind button on the back of the transmitter while turning the transmitter on. The bind button on the back of the transmitter will flash. Release the button after 2–3 seconds.
3. After approximately 5-10 seconds the receiver/5-in-1 should be bound to the transmitter and you should now have full control and function.

Additional Binding Information

Prior to each flight, power on your transmitter and wait about five seconds before you plug the flight battery into the receiver. This allows time for the transmitter to scan and secure two open frequencies. If you plug the flight battery in too quickly and miss the link, the receiver may inadvertently enter bind mode. If this occurs leave the transmitter on, then disconnect and reconnect the flight battery.

Transmitter Control Identification



Control Test

Although each Blade mCX2 model is test flown at the factory, you should test the controls prior to the first flight to ensure none of the servos, linkages or parts were damaged during shipping and handling.

Turn the transmitter on first and lower the throttle stick completely. Then, plug the battery into the battery lead of the 5-in-1 unit.

Note: The connectors on the battery and battery lead are keyed to prevent reverse polarity connection. However, if you force them together in the wrong orientation/wrong polarity it is possible to damage the battery and/or 5-in-1 unit. To help further prevent a reverse polarity connection, one side of the endcap on the battery and the connector on the battery lead of the 5-in-1 unit have a red dot. The connectors are oriented for a proper polarity connection when the red dots are on the same side (usually toward the top of the helicopter).



Position the helicopter to view it from behind. Move the elevator stick on the transmitter forward and aft to check elevator pitch control. When the stick is pushed forward, the right-hand servo should pull the swashplate downward.

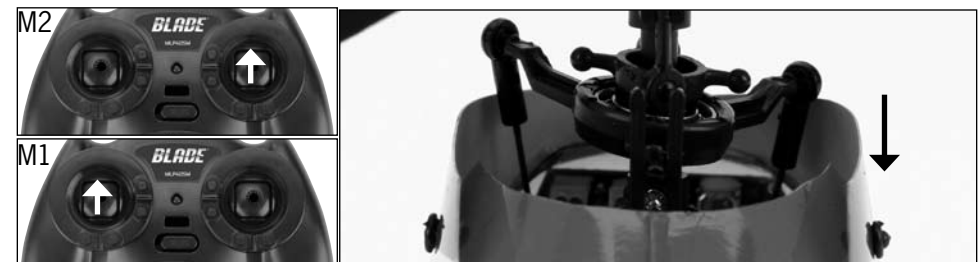

With the stick pulled back, the right-hand servo should push the swashplate upward.



Move the right-hand stick left and right to check aileron roll control. When the stick is pushed to the left, the left-hand servo should pull the swashplate downward.

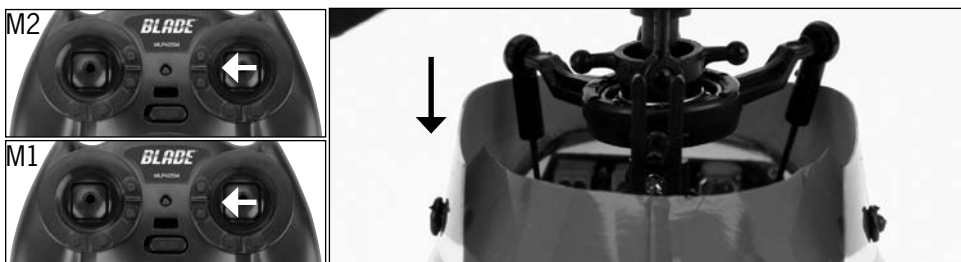

With the stick pushed right, the left-hand servo should push the swashplate upward.



If at any time during the test the controls respond in the opposite direction, it may be necessary to reverse/change the direction of operation of the flight controls. Follow these steps to change the direction the various flight controls:

- Be certain that the battery is disconnected from the battery lead of the 5-in-1 control unit and the transmitter is turned off.
- Push down on the appropriate digital trim button on the transmitter for the control you would like to change the direction of. For example:

Top elevator trim button—elevator channel normal
 Bottom elevator trim button—elevator channel reversed
 Left aileron trim button—aileron channel normal
 Right aileron trim button—aileron channel reversed

- Continue to hold the appropriate trim button while turning the transmitter on.

- Hold the digital trim button down for approximately five seconds, until a series of beeps/tones are heard confirming the selection.
- Connect the battery to the 5-in-1 and complete the flight control test, confirming that all controls are operating in the correct directions.

If you decide to use an E-flite LP5DSM transmitter, please position your channel reversal dip switches as follows:

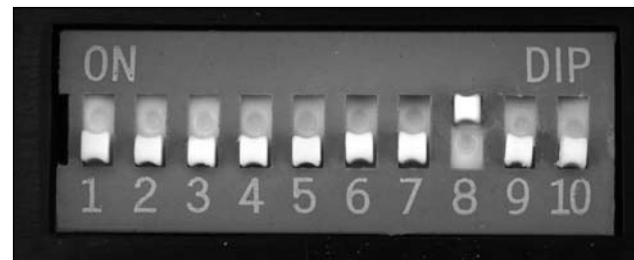

If you've confirmed proper control operation of your Blade mCX2, unplug the flight battery.

Channel 5 Information

Channel 5 affects rate settings of the 5-in-1 Control Unit.

- If using the stock MLP4DSM Transmitter, please read Page 21 of this manual for Dual Rate information.
- If using an LP5DSM Transmitter, please turn the Channel 5 knob clockwise completely.
- If using any other DSM2 compatible transmitter, please ensure Channel 5 is set to default servo reversal and the switch or knob is set to a position that allows full travel control.

Note: This can easily be tested by inducing full cyclic (Aileron/Elevator) input and moving the switch or knob. There's approximately 10–15% less servo travel depending on what position Channel 5 is in.

5-in-1 Control Unit Description, Arming and Motor Control Test

The unique Control Unit installed on your Blade mCX2 is a lightweight combination of main motor electronic speed controls, mixer, gyro, servos and Spektrum DSM2 compatible receiver. The 5-in-1 unit is also equipped with a status indicator LED.

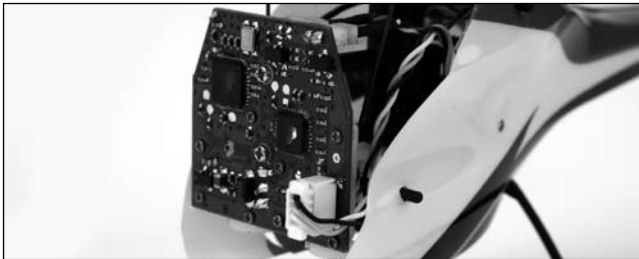

The following checklist contains the steps to ensure proper arming and operation of the control unit, as well as proper motor response:

- ❑ Before each flight ALWAYS turn the transmitter on before connecting the flight battery to the 5-in-1 unit. Never connect the flight battery to the 5-in-1 unit before powering the transmitter on first. After each flight, always disconnect the flight battery from the 5-in-1 unit before powering the transmitter off.

Note: The only time you should connect the flight battery to the 5-in-1 unit before powering the transmitter on is when you are binding the receiver of the 5-in-1 unit to the transmitter. Please see the Transmitter and Receiver Binding section of this manual for more information.

- ❑ The throttle stick MUST be set in the lowest possible position, and the throttle trim must be set to the middle or a lower than middle position (the middle position is indicated by a longer than usual beep/tone), in order for the 5-in-1 unit to arm.

If this is the first test flight, or a test flight following repairs, you should also center the rudder, aileron and elevator trims.

Set throttle stick to lowest position.



Mode 2

Mode 1



Set throttle stick to lowest position.

After confirming that the transmitter has been turned on and that the LED is glowing solid BLUE, it is now safe to connect the flight battery to the 5-in-1 unit.

- ❑ With the transmitter turned on and the LED glowing solid BLUE, it is now safe to connect the flight battery to the 5-in-1 unit.
- ❑ With battery power applied to the 5-in-1 unit, the status indicator LED should glow solid BLUE within a few seconds.

Note: It is extremely important that you do not move, sway or pretend to fly the helicopter once the flight battery is connected because the initialization process and calibration of the gyro has begun. If you do move the helicopter before the LED is solid BLUE, disconnect the flight battery from the 5-in-1 unit and repeat the initialization process.

- ❑ When the status LED becomes solid BLUE, the control unit is initialized and ready for flight. Also, as long as you set the throttle stick and trim to the correct positions during the initialization process, the ESCs/motors will now be armed. Use caution as both rotor blades will now spin with throttle stick input.

Note: If the status LED does not become solid BLUE, please review the following:

- If after BLUE status LED becomes solid, but you have no control of the motors, you have a positive Radio Frequency (RF) link between the transmitter and receiver, but the throttle stick and throttle trim may not be set to the correct positions. Check that the throttle stick is in the lowest possible position, and the throttle trim is set to the middle or a lower than the middle position. If you now have control of the motors, proceed to the next step of the checklist.
- If BLUE status LED is off completely, you do not have a positive RF link between the transmitter and receiver. Check that the transmitter has been powered on and the LED indicator on the transmitter is glowing solid red. If the transmitter is powered on and functioning properly, disconnect the flight battery from the 5-in-1 unit, then reconnect it. The 5-in-1 unit should initialize and arm properly.

Once you place the helicopter in a safe area, free of obstructions, and are clear of the rotor blades, you can safely power up the model to check for proper operation of the motors.

Advance the throttle stick upward slowly, just until both rotor blades begin to spin. DO NOT attempt to fly the helicopter at this time. Note the direction each of the rotor blades spins. When viewed from the top, the upper main rotor blades should spin counterclockwise and the lower main rotor blades should spin clockwise. If either set of rotor blades is operating in the wrong direction, disconnect the battery and reverse the polarity of the corresponding motor's input power leads.

After confirming the rotor blades rotate in the correct direction, confirm that both rotor blades respond properly to rudder control inputs.

With the rotor blades spinning at a low level of power, move the rudder (left-hand) stick all the way to the right. This should cause the speed of the upper main rotor blade to increase, and the speed of the lower main rotor blade to decrease.

Next, move the rudder stick all the way to the left. This should cause the speed of the lower main rotor blade to increase and the speed of the upper main rotor blade

to decrease. If both rotor blades are not responding properly to rudder input, simply reverse the locations of their motor plugs on the 5-in-1 unit.

With both rotor blades rotating in the correct directions and responding properly to rudder inputs, your Blade mCX2 is ready for flight. But you will need to review the following sections of the manual BEFORE proceeding with the first flight.

Understanding the Primary Flight Controls

If you are not familiar with the controls of your Blade mCX2, please take a few minutes to familiarize yourself with them before attempting your first flight.

For Mode 2 transmitters: The left-hand stick on the transmitter controls both throttle (climb/descend) and rudder (yaw left/right). When the throttle stick is in the lowest possible position and throttle trim is set to the middle or a lower than the middle position, the main rotor blades will not spin. Advancing the stick upward increases the speed of the main rotor blades, causing the model to climb.



Decreasing the speed of the main rotor blades by lowering the throttle stick causes the model to descend.



Once the model is off the ground to balance the throttle, carefully move the left-hand stick up and down so the model holds a stationary hover (without climbing or descending).

Moving the rudder stick to the left turns the nose of the helicopter left about the axis of the main shaft. This is accomplished by increasing the speed of the lower main rotor blade while decreasing the speed of the upper main rotor blade.



Moving the stick to the right turns the nose of the helicopter right about the axis of the main shaft. This is accomplished by increasing the speed of the upper main rotor blade while decreasing the speed of the lower main rotor blade.



Use rudder trim to help keep the nose of the helicopter from rotating left or right when in hover with no rudder stick input. For example, if the nose of the helicopter drifts to the right when in hover, add left rudder trim (by pressing the left rudder trim button) until the nose stays as close to straight as possible.

The elevator stick controls both elevator (pitch fore/aft). Push the stick forward to pitch the nose of the helicopter down and fly forward.



Pull the stick back to pitch the tail down and fly backward.



Use elevator trim to keep the helicopter from drifting forward or backward when hovering with no elevator stick input. For example, if the helicopter drifts forward, add back/up elevator trim until it hovers as level as possible with no drifting.

Move the aileron stick left to fly the helicopter left.



Move the stick right to fly the helicopter to the right.



Use aileron trim to keep the helicopter from drifting left or right when hovering with no aileron stick input. For example, if the helicopter drifts to the right when hovering, add left aileron trim until it hovers as level as possible with no drifting to the right.

Once familiar with the primary controls of the helicopter, you are almost ready to fly.

Dual Rates

The MLP4DSM transmitter included with your Blade mCX2 RTF is equipped with a dual rate feature. This feature allows the pilot to toggle between the high and low control rates available for the aileron, elevator and rudder channels. To toggle between the high and low rates, push in on the right-hand stick on the transmitter (while the transmitter is powered on).

The transmitter comes set in high-rate mode. You can tell you are in the high-rate mode when the LED on the transmitter glows solid red. In high-rate mode the controls are allowed to reach their maximum values, typically preferred by experienced pilots for maximum control authority.

Push the right-hand stick in while in high-rate mode to enter low-rate mode. You can tell you are in the low-rate mode when the LED on the transmitter blinks continuously. The low-rate mode is typically preferred by (and best for) first-time, low-time and other pilots most interested in reduced control that allows for smoother and more easily controlled hovering and flying.

Note: The throttle curve in the low rate mode is also different than it is in the high rate mode. This makes low-rate-mode throttle smoother and easier to control.

Choosing a Flying Area

When ready for your first flight, select a relatively open indoor area free of people and obstructions. While it is possible for experienced pilots to fly the Blade mCX2 in relatively small indoor areas with great success, we strongly recommend an area with at least 10-feet by 10-feet of floor space and no less than 8-foot ceilings when making your first few flights.

Once you properly trim your helicopter and become familiar with its handling and capabilities, you will be able to fly in other smaller, less open areas.

Note: The Blade mCX2 is designed and intended to be flown INDOORS ONLY.

Flying the Blade mCX2

Note: In addition to reviewing the flight maneuvers outlined below, we recommend you watch Videos located on the product page for the Blade mCX2 on www.horizonhobby.com to see many of these maneuvers and adjustments performed by the helicopter and pilot.

- Slowly raise the throttle stick, increasing the speed of the main rotor blades until the model begins to lift off. **Do not raise the throttle stick too quickly as the model could climb too fast causing you to lose control or make contact with objects above.**
- Lift the model off the ground just a few inches and concentrate on balancing the throttle stick position so that the model holds a steady hover altitude. In some cases it may be best to make a few short “hops” to an altitude of just a few inches until you become familiar with the control inputs and trim settings required to maintain a steady hover and altitude.

As you will find, the Blade mCX2 requires minor throttle adjustments to maintain its altitude in hover. Remember to keep these throttle adjustments as minimal as possible as large adjustments could result in a loss of control and/or a possible crash.

- While attempting to establish a low-level hover, you can also check to see if any trim adjustments are required to help keep the Blade mCX2 from constantly drifting in various directions. If you find the helicopter constantly drifts without any directional control input, it will be best to land the model before making any adjustments to the trim settings. Additional details regarding the location and function of the trim buttons can be found in the “Understanding the Primary Flight Controls” section of this manual.

- If the nose of the helicopter drifts to the left or right, adjust the rudder trim.
- If the helicopter drifts forward or backward, adjust the elevator trim.
- If the helicopter drifts to the left or right, adjust the aileron trim.

Continue making trim adjustments until the helicopter hovers at a low altitude with very little drifting and directional control input. If the Blade mCX2 is your first helicopter model, it may be best to have the help of an experienced helicopter pilot to trim the model for you before making your first flight.

- With your Blade mCX2 properly trimmed and maintaining a stable low-level hover, practice using the rudder, elevator and aileron controls to familiarize yourself with the helicopter’s responses to control inputs. Remember to keep the control inputs as minimal as possible.

When comfortable with low-level hovering, you can transition to hovering and flying the helicopter at higher altitudes of three to four feet. At these higher altitudes you will become comfortable with the flight characteristics of the Blade mCX2.

- If you feel the helicopter drifting out of control during flight, release all of the controls except for throttle. You will need throttle to maintain altitude, but because of the inherent stability of the coaxial, counter-rotating blade design, the Blade mCX2 will return to a stable hover on its own, if space allows.
- Don’t be afraid to set the helicopter down on the ground quickly by lowering the throttle when approaching walls or other obstacles to help prevent main rotor blade strikes.
- **IN THE EVENT OF A CRASH OR ROTOR BLADE STRIKE, NO MATTER HOW MINOR OR MAJOR, LOWER THE THROTTLE STICK TO THE LOWEST POSSIBLE POSITION AS QUICKLY AS POSSIBLE TO PREVENT DAMAGE TO THE ESCS OF THE 5-IN-1 UNIT. ALSO BE SURE THE THROTTLE TRIM IS SET TO THE MIDDLE POSITION OR TO A LOWER THAN THE MIDDLE POSITION.**

Failure to lower the throttle stick to the lowest possible position in the event of a crash could result in damage to the ESCs in the 5-in-1 unit, which may require replacement of the 5-in-1 unit.

Note: Crash damage is not covered under warranty.

Once you have gained experience and confidence in hovering the Blade mCX2, you can attempt more advanced maneuvers including:

Forward Flight	Skidding Takeoffs
Backward Flight	Skidding Landings
Pirouettes	Spot Landings

Advanced Swashplate Settings

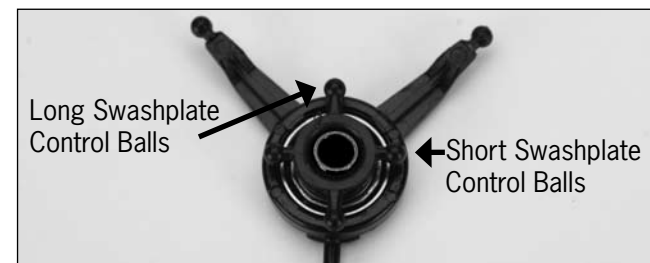

The Blade mCX2 comes with an adjustable swashplate. Advanced pilots may benefit from a more aggressive setup.

To achieve a more aggressive setup, pop off the lower rotor head links and move them onto the longer set of inner swashplate control balls.

Exploded View Parts Listing

#	Item Number	Description
1	EFLH2219B	Stabilizer Flybar Set
2	EFLH2412	Inner Shaft with Head/Hub
3	EFLH2421	Upper Main Blade Set (1 pr)
4	EFLH2421	Upper Main Blade Set (1 pr)
5	EFLH2225	ST1.2 x 5 (2) Screw
6	EFLH2412	Inner Shaft with Head/Hub
7	EFLH2213	Outer Shaft, Main Gear and Bushing Holder Set
8	EFLH2420	Lower Main Blade Set (1 pair)
9	EFLH2213	Outer Shaft, Main Gear and Bushing Holder Set
10	EFLH2217	Lower Rotor Head and Linkage Set
11	EFLH2225	M1.2 x 1.8 (2) Screw
12	EFLH2410	Motor with Pinion, Counterclockwise
13	EFLH2416	Swashplate (1)
14	EFLH2416	Swashplate (1)
15	EFLH2416	Swashplate (1)
16	EFLH2214	Outer Shaft Retaining Collar Set
17	EFLH2409	Motor with Pinion, Clockwise
18	EFLH2418	Servo Pushrod Set
19	EFLH2418	Servo Pushrod Set
20	EFLH2424	Main Frame Set
21	EFLH1066	Replacement Servo Mechanics
22	EFLH2401	.5-in-1 Control Unit, RX/Servos/ESCs/Mxr/Gyro
23	EFLH2225	Washers
24	EFLH2225	ST1.2 x 5 (2) Screw
25	EFLH2427	Complete Red Canopy with LEDs (installed)
26	EFLH2211	Inner Shaft Main Gear
27	EFLH2211	Inner Shaft Main Gear
28	EFLH2222	Landing Skid and Battery Mount Set
29	EFLH2225	M1.2 x 2.5 (2) Screw
30	EFLB1201S	120mAh 1-Cell 3.7V 14C Li-Po
31	EFLH2213	Outer Shaft, Main Gear and Bushing Holder Set
32	EFLH2215	Outer Shaft Bearing 3 x 6 x 2mm (2)
33	EFLH3021	Canopy Mounting Grommets (8)
34	EFLH2427	Complete Red Canopy with LEDs (installed)
35	EFLH2404	Replacement LED Set (4)

Exploded View

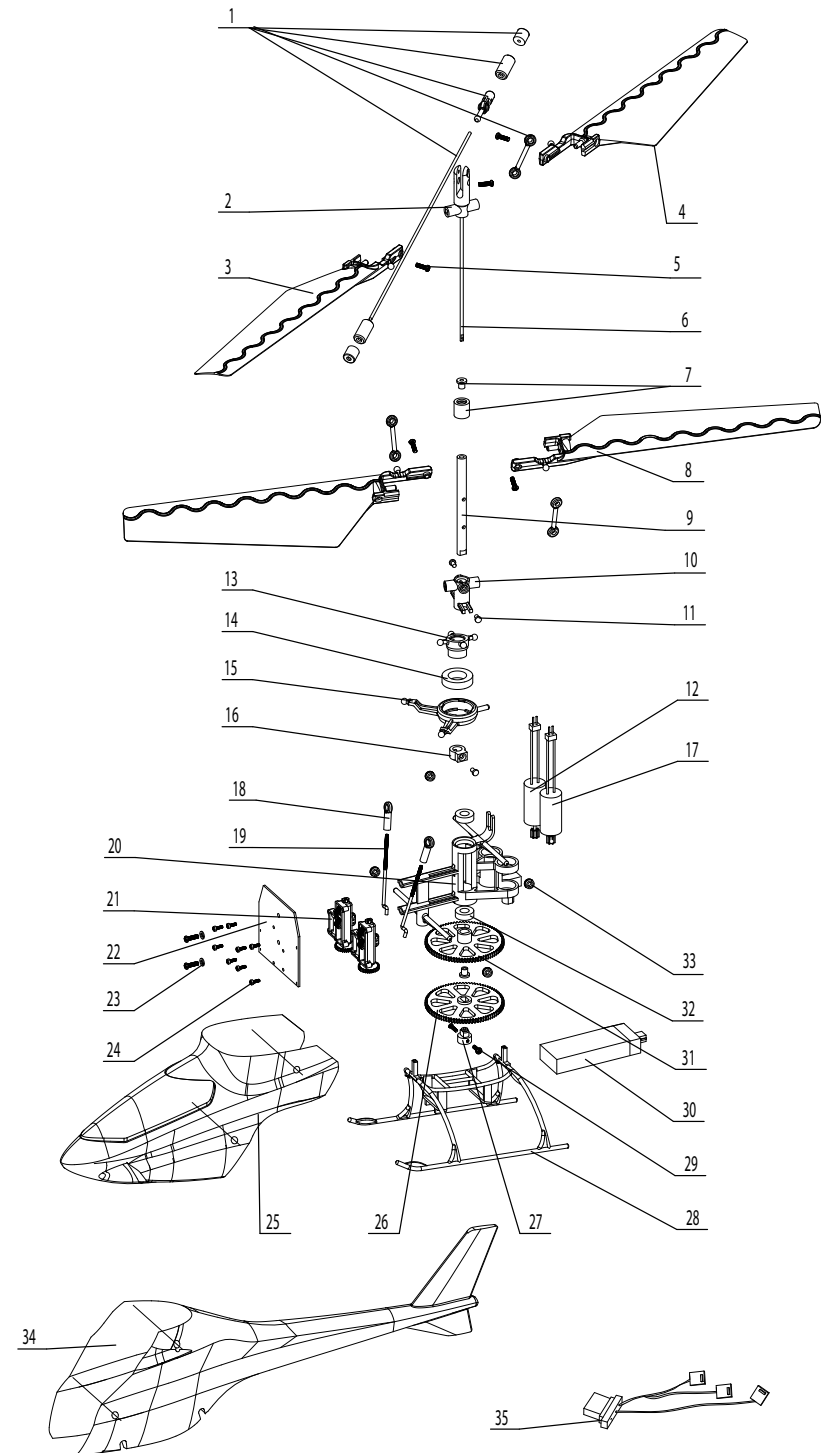

Replacement Parts List

EFLB1201S	120mAh 1-Cell 3.7V 14C Li-Po
EFLC1000	1-Cell 3.7V 0.3A DC Li-Po Charger
EFLH1064B	Blade MLP4DSM 4-channel Transmitter, 2.4GHz
EFLH1066	Replacement Servo Mechanics
EFLH1067	Replacement Servo Retaining Collars
EFLH2211	Inner Shaft Main Gear
EFLH2213	Outer Shaft, Main Gear and Bushing Holder Set
EFLH2214	Outer Shaft Retaining Collar Set
EFLH2215	Outer Shaft Bearing 3 x 6 x 2mm (2)
EFLH2217	Lower Rotor Head and Linkage Set
EFLH2219B	Stabilizer Flybar Set
EFLH2222	Landing Skid and Battery Mount Set
EFLH2225	Hardware Set
EFLH2401	5-in-1 Control Unit, Receiver/Servos/ESCs/Mixer/Gyro
EFLH2404	Replacement LED Set (4)
EFLH2409	Motor with Pinion, Clockwise
EFLH2410	Motor with Pinion, Counter-Clockwise
EFLH2412	Inner Shaft with Head/Hub
EFLH2416	Swashplate (1)
EFLH2418	Servo Pushrod Set
EFLH2420	Lower Main Blade Set (1 pr)
EFLH2421	Upper Main Blade Set (1 pr)
EFLH2424	Main Frame Set
EFLH2427	Complete Red Canopy with LEDs (Installed)
EFLH3021	Canopy Mounting Grommets (8)

Option Parts

EFLB1501S	150mAh 1-Cell 3.7V Li-Po
EFLC1005	6V AC Power Supply
EFLH2220GL	Lower Main Blade Set, Glow-in-the-Dark (1 pr)
EFLH2221GL	Upper Main Blade Set, Glow-in-the-Dark (1 pr)
EFLH2222GL	Landing Skid and Battery Mount Set, Glow-in-the-Dark
EFLH2428	Carbon Fiber Tail Boom with Fin
EFLH3023	Carbon Fiber Training Gear Set

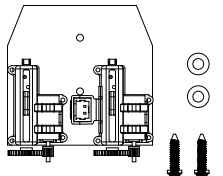
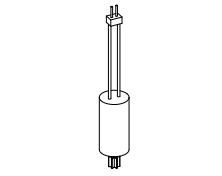
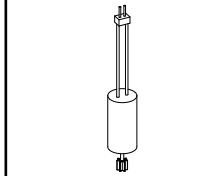
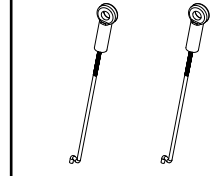
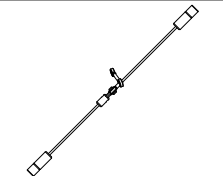
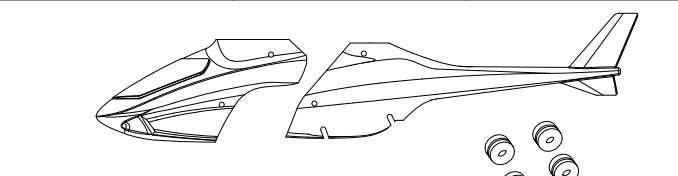
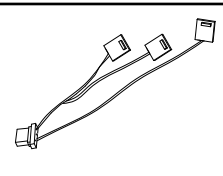
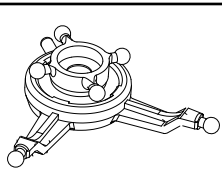
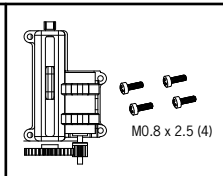
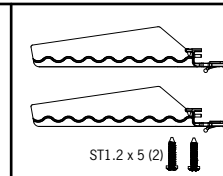
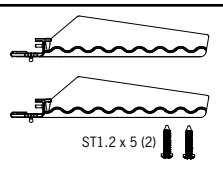
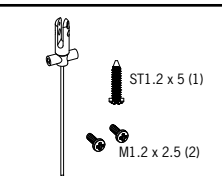
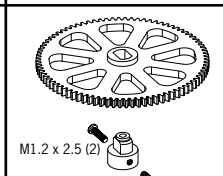
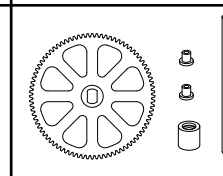
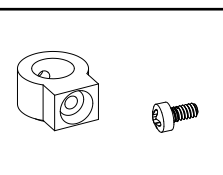
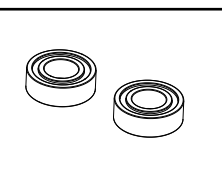
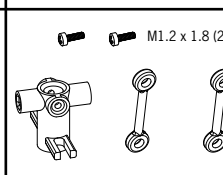
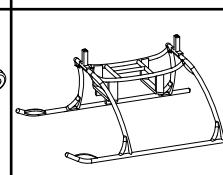
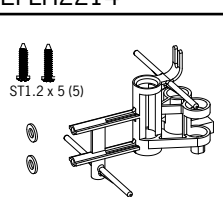
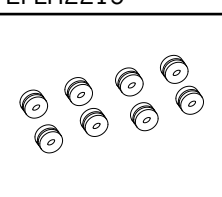
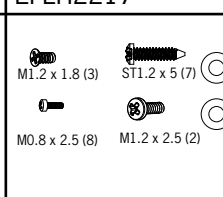
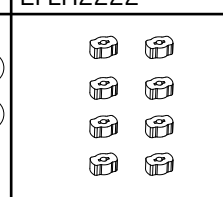
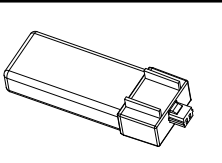
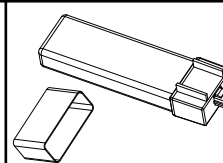
 EFLH2401 ST1.2 x 5 (2)	 EFLH2409	 EFLH2410	 EFLH2418
 EFLH2219B	 EFLH2427		
 EFLH2404	 EFLH2416	 EFLH1066 M0.8 x 2.5 (4)	 EFLH2421 ST1.2 x 5 (2)
 EFLH2420 ST1.2 x 5 (2)	 EFLH2412 ST1.2 x 5 (1) M1.2 x 2.5 (2)	 EFLH2211 M1.2 x 2.5 (2)	 EFLH2213
 EFLH2214	 EFLH2215	 EFLH2217 M1.2 x 1.8 (2)	 EFLH2222
 EFLH2424 ST1.2 x 5 (5)	 EFLH3021	 EFLH2225 M1.2 x 1.8 (3) ST1.2 x 5 (7) M0.8 x 2.5 (8) M1.2 x 2.5 (2)	 EFLH1067
	 EFLB1201S	 EFLHB1501S	

Warranty

Warranty Period

Exclusive Warranty- Horizon Hobby, Inc., (Horizon) warrants that the Products purchased (the "Product") will be free from defects in materials and workmanship at the date of purchase by the Purchaser.

Limited Warranty

Horizon reserves the right to change or modify this warranty without notice and disclaims all other warranties, express or implied.

(a) This warranty is limited to the original Purchaser ("Purchaser") and is not transferable. REPAIR OR REPLACEMENT AS PROVIDED UNDER THIS WARRANTY IS THE EXCLUSIVE REMEDY OF THE PURCHASER. This warranty covers only those Products purchased from an authorized Horizon dealer. Third party transactions are not covered by this warranty. Proof of purchase is required for warranty claims. Further, Horizon reserves the right to change or modify this warranty without notice and disclaims all other warranties, express or implied.

(b) Limitations- HORIZON MAKES NO WARRANTY OR REPRESENTATION, EXPRESS OR IMPLIED, ABOUT NON-INFRINGEMENT, MERCHANTABILITY OR FITNESS FOR A PARTICULAR PURPOSE OF THE PRODUCT. THE PURCHASER ACKNOWLEDGES THAT THEY ALONE HAVE DETERMINED THAT THE PRODUCT WILL SUITABLY MEET THE REQUIREMENTS OF THE PURCHASER'S INTENDED USE.

(c) Purchaser Remedy- Horizon's sole obligation hereunder shall be that Horizon will, at its option, (i) repair or (ii) replace, any Product determined by Horizon to be defective. In the event of a defect, these are the Purchaser's exclusive remedies. Horizon reserves the right to inspect any and all equipment involved in a warranty claim. Repair or replacement decisions are at the sole discretion of Horizon. This warranty does not cover cosmetic damage or damage due to acts of God, accident, misuse, abuse, negligence, commercial use, or modification of or to any part of the Product. This warranty does not cover damage due to improper installation, operation, maintenance, or attempted repair by anyone other than Horizon. Return of any goods by Purchaser must be approved in writing by Horizon before shipment.

Damage Limits

HORIZON SHALL NOT BE LIABLE FOR SPECIAL, INDIRECT OR CONSEQUENTIAL DAMAGES, LOSS OF PROFITS OR PRODUCTION OR COMMERCIAL LOSS IN ANY WAY CONNECTED WITH THE PRODUCT, WHETHER SUCH CLAIM IS BASED IN CONTRACT, WARRANTY, NEGLIGENCE, OR STRICT LIABILITY. Further, in no event shall the liability of Horizon exceed the individual price of the Product on which liability is asserted. As Horizon has no control over use, setup, final assembly, modification or misuse, no liability shall be assumed nor accepted for any resulting damage or injury. By the act of use, setup or assembly, the user accepts all resulting liability.

If you as the Purchaser or user are not prepared to accept the liability associated with the use of this Product, you are advised to return this Product immediately in new and unused condition to the place of purchase.

Law: These Terms are governed by Illinois law (without regard to conflict of law principals).

Safety Precautions

This is a sophisticated hobby Product and not a toy. It must be operated with caution and common sense and requires some basic mechanical ability. Failure to operate this Product in a safe and responsible manner could result in injury or damage to the Product or other property. This Product is not intended for use by children without direct adult supervision. The Product manual contains instructions for safety, operation and maintenance. It is essential to read and follow all the instructions and warnings in the manual, prior to assembly, setup or use, in order to operate correctly and avoid damage or injury.

Questions, Assistance, and Repairs

Your local hobby store and/or place of purchase cannot provide warranty support or repair. Once assembly, setup or use of the Product has been started, you must contact Horizon directly. This will enable Horizon to better answer your questions and service you in the event that you may need any assistance. For questions or assistance, please direct your email to productsupport@horizonhobby.com, or call 877.504.0233 toll free to speak to a Product Support representative.

Inspection or Repairs

If this Product needs to be inspected or repaired, please call for a Return Merchandise Authorization (RMA). Pack the Product securely using a shipping carton. Please note that original boxes may be included, but are not designed to withstand the rigors of shipping without additional protection. Ship via a carrier that provides tracking and insurance for lost or damaged parcels, as Horizon is not responsible for merchandise until it arrives and is accepted at our facility. A Service Repair Request is available at www.horizonhobby.com on the "Support" tab. If you do not have internet access, please include a letter with your complete name, street address, email address and phone number where you can be reached during business days, your RMA number, a list of the included items, method of payment for any non-warranty expenses and a brief summary of the problem. Your original sales receipt must also be included for warranty consideration. Be sure your name, address, and RMA number are clearly written on the outside of the shipping carton.

Warranty Inspection and Repairs

To receive warranty service, you must include your original sales receipt verifying the proof-of-purchase date. Provided warranty conditions have been met, your Product will be repaired or replaced free of charge. Repair or replacement decisions are at the sole discretion of Horizon Hobby.

Non-Warranty Repairs

Should your repair not be covered by warranty the repair will be completed and payment will be required without notification or estimate of the expense unless the expense exceeds 50% of the retail purchase cost. By submitting the item for repair you are agreeing to payment of the repair without notification. Repair estimates are available upon request. You must include this request with your repair. Non-warranty repair estimates will be billed a minimum of ½ hour of labor. In addition you will be

billed for return freight. Please advise us of your preferred method of payment. Horizon accepts money orders and cashiers checks, as well as Visa, MasterCard, American Express, and Discover cards. If you choose to pay by credit card, please include your credit card number and expiration date. Any repair left unpaid or unclaimed after 90 days will be considered abandoned and will be disposed of accordingly. Please note: non-warranty repair is only available on electronics and model engines.

Country of Purchase	Horizon Hobby	Address	Phone Number/ Email
United States	Horizon Service Center (Electronics and engines)	4105 Fieldstone Rd Champaign, Illinois 61822 USA	877-504-0233 productsupport @horizonhobby.com
	Horizon Product Support (All other products)	4105 Fieldstone Rd Champaign, Illinois 61822 USA	877-504-0233 productsupport @horizonhobby.com
United Kingdom	Horizon Hobby UK	Units 1-4 Ploysters Rd Staple Tye Harlow, Essex CM18 7NS United Kingdom	+44 (0) 1279 641 097 sales@horizonhobby.co.uk
Germany	Horizon Technischer Service	Hamburger Str. 10 25335 Elmshorn Germany	+49 4121 46199 66 service@horizonhobby.de
France	Horizon Hobby SAS	14 Rue Gustave Eiffel Zone d'Activité du Réveil Matin 91230 Montgeron	+33 (0) 1 60 47 44 70

Compliance Information for the European Union

CE Declaration of Conformity (in accordance with ISO/IEC 17050-1)
No. HH2010021401

Product(s): mCX2 RTF
Item Number(s): EFLH2400
Equipment class: 1

The object of declaration described above is in conformity with the requirements of the specifications listed below, following the provisions of the European R&TTE directive 1999/5/EC:

EN 300-328 Technical requirements for Radio equipment
EN 301 489-1, 301 489-17 General EMC requirements
EN 60950 Safety

Declaration of Conformity (in accordance with ISO/IEC 17050-1)
No. HH2010021402

Product(s): mCX2 BNF
Item Number(s): EFLH2480
Equipment class: 1

The object of declaration described above is in conformity with the requirements of the specifications listed below, following the provisions of the European R&TTE directive 1999/5/EC:

EN 301 489-1, 301 489-17 General EMC requirements

Signed for and on behalf of:
Horizon Hobby, Inc.
Champaign, IL USA
Feb 14, 2010

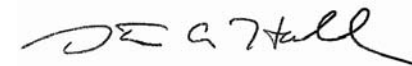

Steven A. Hall
Vice President
International Operations and Risk Management
Horizon Hobby, Inc.



Instructions for Disposal of WEEE by Users in the European Union

This product must not be disposed of with other waste. Instead, it is the user's responsibility to dispose of their waste equipment by handing it over to a designated collection point for the recycling of waste electrical and electronic equipment. The separate collection and recycling of your waste equipment at the time of disposal will help to conserve natural resources and ensure that it is recycled in a manner that protects human health and the environment. For more information about where you can drop off your waste equipment for recycling, please contact your local city office, your household waste disposal service or where you purchased the product.

© 2010 Horizon Hobby, Inc.

E-flite® products are distributed exclusively by Horizon Hobby, Inc.

US Patent 7,391,320

Other Patents Pending

DSM and DSM2 are trademarks or registered trademarks of Horizon Hobby, Inc.

The Spektrum trademark is used with permission of Bachmann Industries, Inc.

Spektrum radios and accessories are exclusively available from Horizon Hobby, Inc.