

HORIZON[®]
H O B B Y

Eflite[™]
ADVANCING ELECTRIC FLIGHT

UMX[™] Ultrix[™]

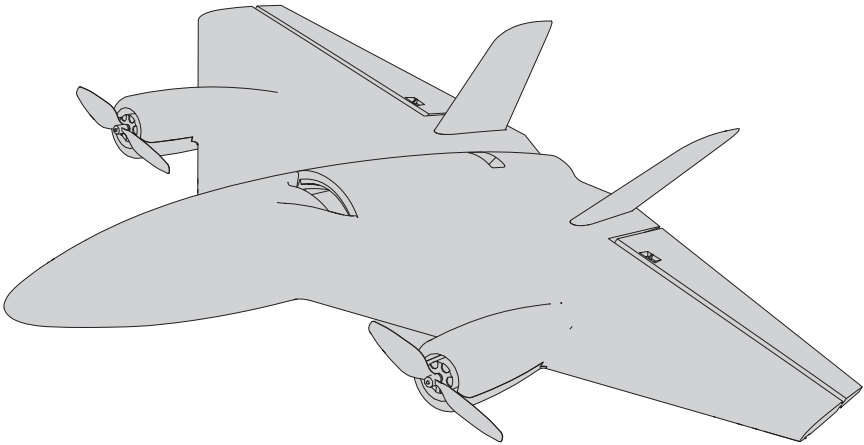

**Instruction Manual
Bedienungsanleitung
Manuel d'utilisation
Manuale di Istruzioni**

SAFE[®] 

SAFE[®] Select Technology, Optional Flight Envelope Protection

AS3X[®] 

BNF[®]
BASIC

NOTICE

All instructions, warranties and other collateral documents are subject to change at the sole discretion of Horizon Hobby, LLC. For up-to-date product literature, visit www.horizonhobby.com or www.towerhobbies.com and click on the support or resources tab for this product.

Meaning of Special Language

The following terms are used throughout the product literature to indicate various levels of potential harm when operating this product:

WARNING: Procedures, which if not properly followed, create the probability of property damage, collateral damage, and serious injury OR create a high probability of superficial injury.

CAUTION: Procedures, which if not properly followed, create the probability of physical property damage AND a possibility of serious injury.

NOTICE: Procedures, which if not properly followed, create a possibility of physical property damage AND little or no possibility of injury.



WARNING: Read the ENTIRE instruction manual to become familiar with the features of the product before operating. Failure to operate the product correctly can result in damage to the product, personal property and cause serious injury.

This is a sophisticated hobby product. It must be operated with caution and common sense and requires some basic mechanical ability. Failure to operate this Product in a safe and responsible manner could result in injury or damage to the product or other property. This product is not intended for use by children without direct adult supervision. Do not use with incompatible components or alter this product in any way outside of the instructions provided by Horizon Hobby, LLC. This manual contains instructions for safety, operation and maintenance. It is essential to read and follow all the instructions and warnings in the manual, prior to assembly, setup or use, in order to operate correctly and avoid damage or serious injury.

Age Recommendation: Not for children under 14 years. This is not a toy.

Safety Precautions and Warnings

As the user of this product, you are solely responsible for operating in a manner that does not endanger yourself and others or result in damage to the product or the property of others.

- Always keep a safe distance in all directions around your model to avoid collisions or injury. This model is controlled by a radio signal subject to interference from many sources outside your control. Interference can cause momentary loss of control.
- Always operate your model in open spaces away from full-size vehicles, traffic and people.
- Always carefully follow the directions and warnings for this and any optional support equipment (chargers, rechargeable battery packs, etc.).
- Always keep all chemicals, small parts and anything electrical out of the reach of children.
- Always avoid water exposure to all equipment not specifically designed and protected for this purpose. Moisture causes damage to electronics.
- Never place any portion of the model in your mouth as it could cause serious injury or even death.
- Never operate your model with low transmitter batteries.
- Always keep aircraft in sight and under control.
- Always use fully charged batteries.
- Always keep transmitter powered on while aircraft is powered.
- Always remove batteries before disassembly.
- Always keep moving parts clean.
- Always keep parts dry.
- Always let parts cool after use before touching.
- Always remove batteries after use.
- Always ensure failsafe is properly set before flying.
- Always engage throttle cut before approaching the aircraft.
- Never operate aircraft with damaged wiring.
- Never touch moving parts.



WARNING AGAINST COUNTERFEIT PRODUCTS: If you ever need to replace your Spektrum receiver found in a Horizon Hobby product, always purchase from Horizon Hobby, LLC or a Horizon Hobby authorized dealer to ensure authentic high-quality Spektrum product. Horizon Hobby, LLC disclaims all support and warranty with regards, but not limited to, compatibility and performance of counterfeit products or products claiming compatibility with DSM or Spektrum technology.

Box Contents

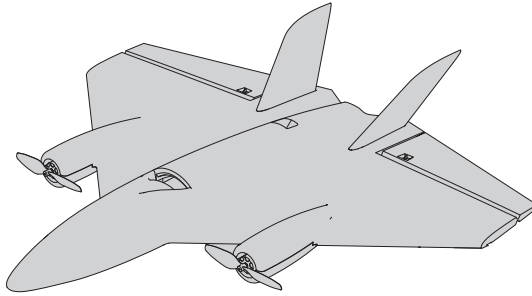
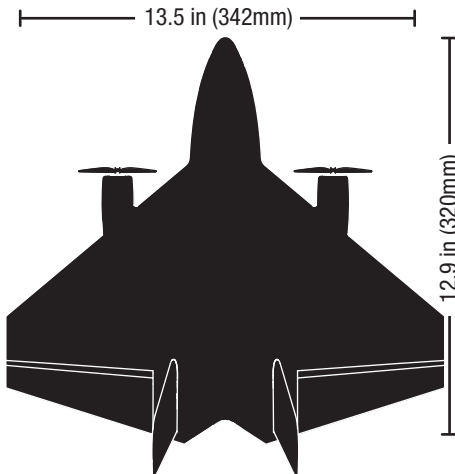

Table of Contents

Preflight Checklist.....	4	Post Flight Checklist	9
Transmitter Setup	4	Service of Power Components	9
Install the Vertical Stabilizers.....	4	Replacement Parts List	9
Adjusting the Center of Gravity (CG)	5	Recommended Parts List	10
Transmitter and Receiver Binding	5	Optional Parts	10
Arming the ESC	6	AS3X Troubleshooting Guide	10
Low Voltage Cutoff (LVC)	6	Troubleshooting Guide	11
Control Centering	6	Limited Warranty	12
Settings for Control Horns	6	Warranty and Service Contact Information	13
Control Direction Test.....	7	FCC Information.....	13
SMART Technology Telemetry	7	IC Information	13
SAFE® Technology	8	Compliance Information for the European Union.....	14
Flying Tips and Repairs.....	8		

Specifications



Flying Weight



2.29oz
(65g)

Components

Installed

Motors	EFLUM0805 0805 - 13,500kv
Receiver	EFL DSMX® RX/ESC unit (EFLU6453)
Servo	(2) 2.3-Gram Performance Linear Long Throw Servo (SPMSA2030L)

Needed to Complete

Transmitter	Spektrum™ DSM2®/DSMX® with dual-rates (DX4e and up)
Battery	500mAh 1S 25C Li-Po (EFLB5001S25)
Battery Charger	1S 3.7V Li-Po (SPMXC1040)

Preflight Checklist

1	Remove and inspect contents.
2	Read the instruction manual thoroughly.
3	Charge the flight battery.
4	Program your transmitter.
5	Install the fully charged flight battery in the aircraft.
6	Check the center of gravity (CG).
6	Bind the aircraft to your transmitter.

8	Make sure all linkages move freely.
9	Perform the control direction test.
10	Adjust the flight controls and transmitter as needed.
11	Perform a radio system range test.
12	Find a safe open area to fly.
13	Plan flight for flying field conditions.

Transmitter Setup

IMPORTANT: After you set up your model, always rebind the transmitter and receiver to set the desired failsafe positions. If your transmitter allows it, enable the throttle cut feature. Always engage throttle cut before approaching the aircraft.

IMPORTANT: The Ultrix **DOES NOT** need elevon mixing. The elevon mixing is handled in the receiver.

Dual Rates

Flight modes and dual rates/expo should be on the same switch.

Low rate is recommended for the initial flights.

NOTICE: To ensure AS3X® technology functions properly, do not lower rate values below 50%.

Expo

After your initial flights, you may adjust the expo value to better suit your flying style.

Control For Optional Lights

The optional LEDs are controlled from channel 6. In the channel input menu, set channel 6 (Aux1) to a momentary switch (I). In the Servo Setup menu, reverse channel 6 (Aux1). The LEDs will change to the next light pattern each time channel 6 is cycled.

Computerized Transmitter Setup

Start all transmitter programming with a blank ACRO model (do a model reset), then name the model.

Mode switch	Assign Ch5 to switch B (Channel input config)
Servo Setup	Reversing-All Normal Travel 100%
Rates and Expo (ail, ele, rud)	Switch of your choice, we recommend switch B
(Pos 0) Rates	100%
(Pos 0) Expo	0%
(Pos 1) Rate	70%
(Pos 1) Expo	30%
(Pos 2) Rate	100%
(Pos 2) Expo	40%
Timer	5–8 minutes
Throttle Cut	Assign to Switch H (-130%)

With both Ch 5 and Rates/Expo assigned to the same switch, there are three flight modes.

(Pos 0) SAFE

(Pos 1) AS3X low rate

(Pos 2) AS3X high rate

Install the Vertical Stabilizers

Press the vertical stabilizers into position.

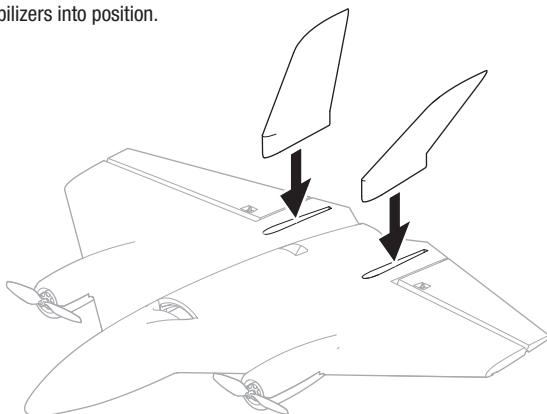

Adjusting the Center of Gravity (CG)

The CG location is **175mm** back from the nose, which was determined with the recommended battery at the front of the battery tray.

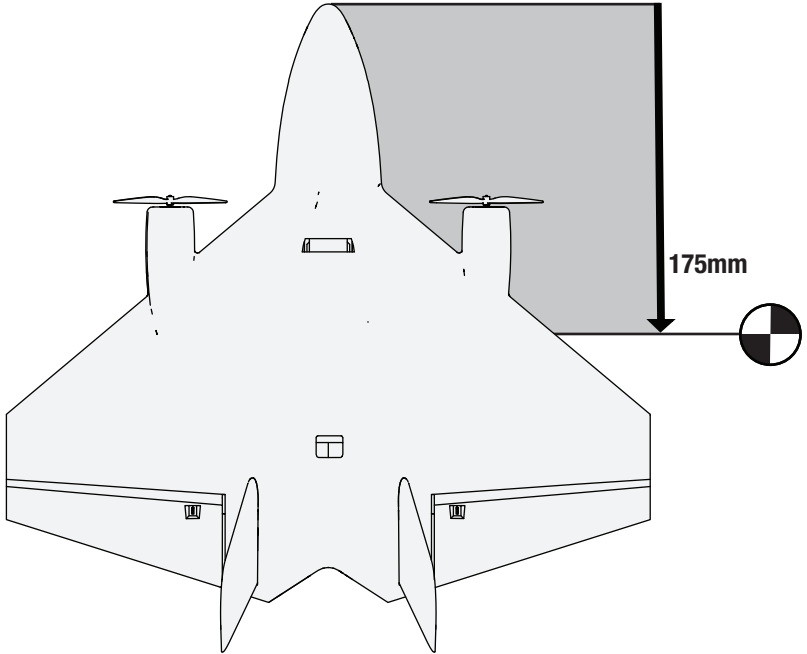

Transmitter and Receiver Binding

Binding is the process of linking your transmitter and receiver. You need to 'bind' your chosen Spektrum™ DSM2®/DSMX® technology equipped aircraft transmitter to the receiver for proper operation.

Binding Procedure

1. Refer to your transmitter manual for instruction on binding the transmitter to a receiver.
2. Ensure the flight battery is not connected to the aircraft.
3. Depending on your transmitter, either power off the transmitter or ensure the RF signal is off.
4. Connect the flight battery in the Aircraft. The LED's will begin flashing slowly, turn the aircraft upside down until the LED does a slow blue flash, indicating the Ultrix is in bind mode.
5. Make sure the transmitter controls are at neutral and the throttle and throttle trim are in the low position.
6. Place the transmitter in bind mode. Refer to your transmitter manual for binding instructions.
7. After 5-10 seconds, the receiver will connect and the motor will arm. If you encounter problems refer to the *Troubleshooting Guide* at the back of the manual.

For subsequent flights, power on the transmitter for 5 seconds before connecting the flight battery.

LED Indicator on Receiver

Waiting to Bind	Slow Flashing Blue
Connected, throttle not at zero	Fast Flashing Blue
SAFE Mode	Blue Solid
AS3X Mode	Red Solid
Low Voltage Cutoff	Red Flashing

Arming the ESC

Arming the ESC also occurs after binding as previously described, but subsequent connection of a flight battery requires the steps below.

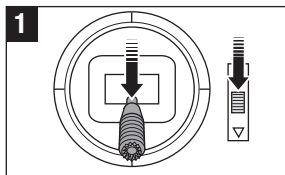

Lower throttle and throttle trim to lowest settings.
Power on the transmitter then wait 5 seconds

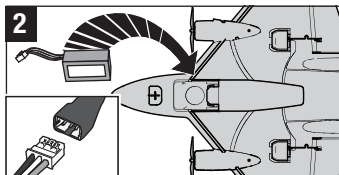

Install the flight battery and connect it to the ESC.
Slide battery to nose

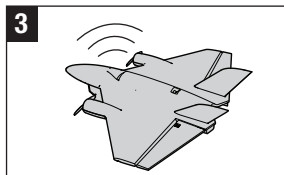

Keep plane immobile, upright, and away from wind for 5 seconds.
A series of tones indicates aircraft is armed and ready.

Low Voltage Cutoff (LVC)

When a Li-Po battery is discharged below 3V per cell, it will not hold a charge. The aircraft's ESC protects the flight battery from over-discharge using Low Voltage Cutoff (LVC). Before the battery charge decreases too much, LVC removes power supplied to the motor. Power to the motor quickly decreases and increases, showing that some battery power is reserved for flight control and safe landing.

When the motor power pulses, land the aircraft immediately and recharge the flight battery.

Disconnect and remove the Li-Po battery from the aircraft after use to prevent trickle discharge. During storage, make sure the battery charge does not fall below 3V per cell.

TIP: Due to the quiet nature of the aircraft, you may not hear the pulsing of the motor.

For your first flights, set your transmitter timer or a stopwatch to 3 minutes. Adjust your timer for longer or shorter flights once you have flown the aircraft. Flights of 4 minutes or more are achievable if using proper throttle management.

NOTICE: Repeated flying to LVC will damage the battery.

Control Centering

Before the first flights, or in the event of an accident, make sure the flight control surfaces are centered. Adjust the linkages mechanically if the control surfaces are not centered. Use of the transmitter sub-trims may not correctly center the aircraft control surfaces due to the mechanical limits of linear servos.

1. Ensure SAFE Select is OFF.
2. Make sure the control surfaces are neutral when the transmitter controls and trims are centered. The transmitter sub-trim must always be set to zero.
3. When needed, use a pair of pliers to carefully bend the metal linkage (see illustration).
4. Make the U-shape narrower to make the connector shorter. Make the U-shape wider to make the linkage longer.

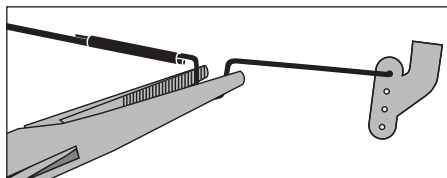

Centering Controls After First Flights

For best performance with AS3X, it is important that excessive trim is not used. Do not trim the aircraft while SAFE Select is active. Always trim the aircraft in AS3X mode. If the model requires excessive transmitter trim (4 or more clicks of trim per channel), return the transmitter trim to zero and adjust the linkages mechanically so that the control surfaces are in the flight trimmed position.

Settings for Control Horns

The following illustration shows the factory settings for linkages on the control horns. After the initial flights, adjust the linkage positions for the desired control response.

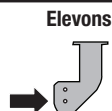

Control Direction Test

Properly bind your aircraft and transmitter before doing these tests. Verify the linkages move freely. Switch ON the transmitter and connect the battery. Use the transmitter to operate the aileron and elevator controls. View the aircraft from the rear when checking the control directions.

Ailerons

1. Move the aileron stick to the left. The right elevon should move down and the left elevon up, which will cause the aircraft to bank left in flight.
2. Move the aileron stick to the right. The right elevon should move up and the left elevon down, which will cause the aircraft to bank right in flight.

Elevators

3. Pull the elevator stick back. The elevons should move up, which will cause the aircraft to pitch up in flight.
4. Push the elevator stick forward. The elevons should move down, which will cause the aircraft to pitch down in flight.

Rudder/ Differential Thrust

5. Move the rudder stick to the left. The right motor will accelerate, which will cause the aircraft to yaw left in flight.
6. Move the rudder stick to the right. The left motor will accelerate, which will cause the aircraft to yaw right in flight.

Tip: The motors will not accelerate with rudder input when the throttle is in the OFF position.

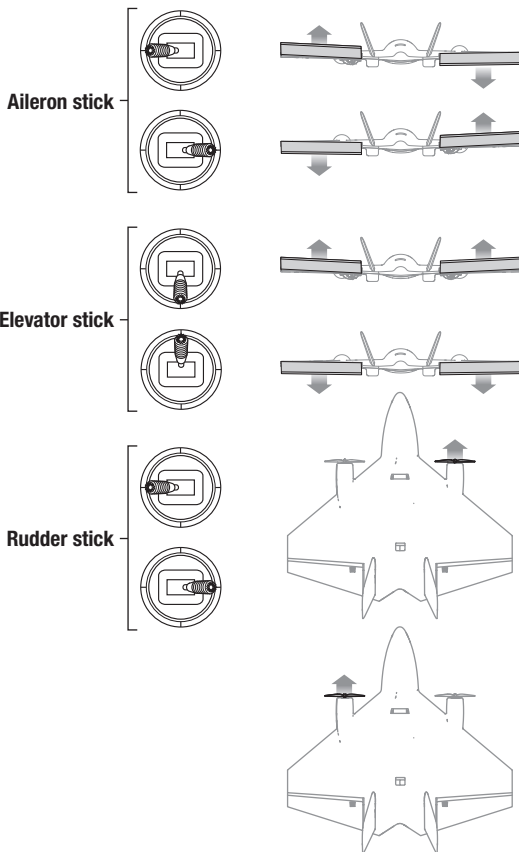

SMART Technology Telemetry

This aircraft includes Spektrum SMART Technology in the receiver, which can provide telemetry information like battery voltage. To take advantage of SMART Technology, you will need a compatible transmitter. A firmware update for your transmitter may be required.

To View SMART Telemetry:

1. Begin with the transmitter bound to the receiver
2. Power on the transmitter.
3. Power on the aircraft.
4. The SMART Logo appears under the battery logo on the home page. A signal bar appears in the top left corner of the screen.
5. Scroll past the servo monitor to view SMART technology screens.

For more information about compatible transmitters, firmware updates, and how to use the SMART Technology on your transmitter, visit www.SpektrumRC.com.

SAFE® Technology

The Ultrix has two flight modes on Channel 5, SAFE and AS3X. When flying in SAFE mode, the aircraft will return to level flight any time the aileron and elevator controls are at neutral. Applying aileron or elevator control will cause the airplane to bank, climb or dive. The amount the stick is moved will determine the attitude the airplane flies. Holding full control will push the aircraft to the pre-determined bank and pitch limits, but it will not go past those angles.

When flying in SAFE mode, it is normal to hold the control stick deflected with moderate aileron input when flying

through a turn. To fly smoothly with SAFE, avoid making frequent control changes and don't attempt to correct for minor deviations. Holding deliberate control inputs will command the aircraft to fly at a specific angle, and the model will make all corrections to maintain that flight attitude.

Return the elevator and aileron controls to neutral before switching from SAFE mode to AS3X mode. If you do not neutralize controls when switching into AS3X mode, the control inputs used for SAFE mode will be excessive for AS3X mode and the aircraft will react immediately.

Differences between SAFE and AS3X modes

This section is generally accurate but does not take into account flight speed, battery charge status, and other limiting factors.

		SAFE Select	AS3X
Control Input	Control stick is neutralized	Aircraft will self level	Aircraft will continue to fly at its present attitude
	Holding a small amount of control	Aircraft will bank or pitch to a moderate angle and maintain the attitude	Aircraft will continue to pitch or roll slowly
	Holding full control	Aircraft will bank or pitch to the predetermined limits and maintain the attitude	Aircraft will continue to roll or pitch rapidly

Flying Tips and Repairs

WARNING: If your transmitter supports it, always engage throttle cut before approaching the aircraft.

Range Check your Radio System

After final assembly, range check the radio system with the aircraft. Refer to your specific transmitter instruction manual for range test information.

Flying

We recommend flying your aircraft outside in no greater than moderate winds or inside in a large gymnasium. Always avoid flying near houses, trees, wires and buildings. You should also be careful to avoid flying in areas where there are many people, such as busy parks, schoolyards

Landing

Always land into the wind. During the flare, keep the wings level and the aircraft pointed into the wind. Slowly lower the throttle while easing back on the elevator to bring the aircraft gently down for a belly landing.

TIP: We recommend belly landings on a soft surface. If hard surfaces are your only option for landings, consider installing the optional nose skid.

NOTICE: Always fully lower the throttle at touch down when landing the aircraft to prevent damage to the propellers and motors.

Failure to lower the throttle stick and trim to the lowest possible positions during a crash could result in damage to the ESC in the receiver unit.

Over-Current Protection (OCP)

The aircraft is equipped with over-current protection. OCP protects the ESC from overheating and stops the motor when the transmitter throttle is set too high and the rotor cannot turn. OCP will only activate when the throttle is positioned just above 1/2 throttle. After the ESC stops the motor, fully lower the throttle to re-arm the ESC.

Repairs

Crash damage is not covered under warranty. Repair this aircraft using foam-compatible CA glue or clear tape. Only use foam-compatible CA glue as other types of glue can damage the foam. When parts are not repairable, see the Replacement Parts List for ordering by item number.

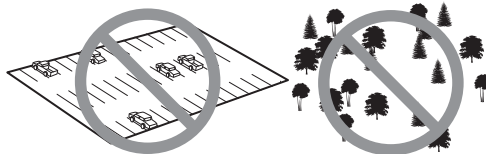

or soccer fields. Consult local laws and ordinances before choosing a location to fly your aircraft.

Hand Launching

To hand launch the aircraft, pinch the wing from the rear between the vertical stabilizers with your thumb on top. We recommend launching in SAFE flight mode. Advance to full throttle and release the aircraft with a gentle forward toss, slightly up (5–10 degrees above the horizon), and directly into the wind. After the model gains altitude and speed, decrease the throttle as you desire.

Post Flight Checklist

1	Disconnect the flight battery from the ESC.
2	Power OFF the transmitter.
3	Remove the flight battery from the aircraft.
4	Recharge the flight battery.

5	Repair or replace all damaged parts.
6	Store the flight battery apart from the aircraft and monitor the battery charge.
7	Make note of the flight conditions and flight plan results, planning for future flights.

Service of Power Components

Disassembly



CAUTION: DO NOT handle the motor while the flight battery is connected. Personal injury could result.

1. The motor covers are secured to the wing using clear tape.
2. Disconnect the motor connector from the receiver.
3. Cut the tape and decals on the fuselage and carefully remove the motor covers.
4. Remove the 2 screws from the motor mount to remove the motor mount and motor from the wing.
5. Remove the 3 screws from the back of the motor to remove it from the mount.
6. The propeller is a press fit, hold the motor and pull the propeller at the hub to remove it.

Assembly

Assemble in reverse order, connecting the motor covers to the wing with clear tape.

Replacement Parts List

	Part #	Description
A	EFLP60205	60mm x 2.5mm Prop Set (4)
B	EFLU6451	Replacement Airframe: Ultrix
C	EFLU6452	Vertical Fin Set: Ultrix
D	EFLU6453	RX/ESC Unit: Ultrix
E	EFLU6454	Pushrod and Skid: Ultrix
F	EFLUM0805	0805-13,500Kv Brushless Motor
G	SPMSA2030L	2.3 g Linear Long Throw Servo

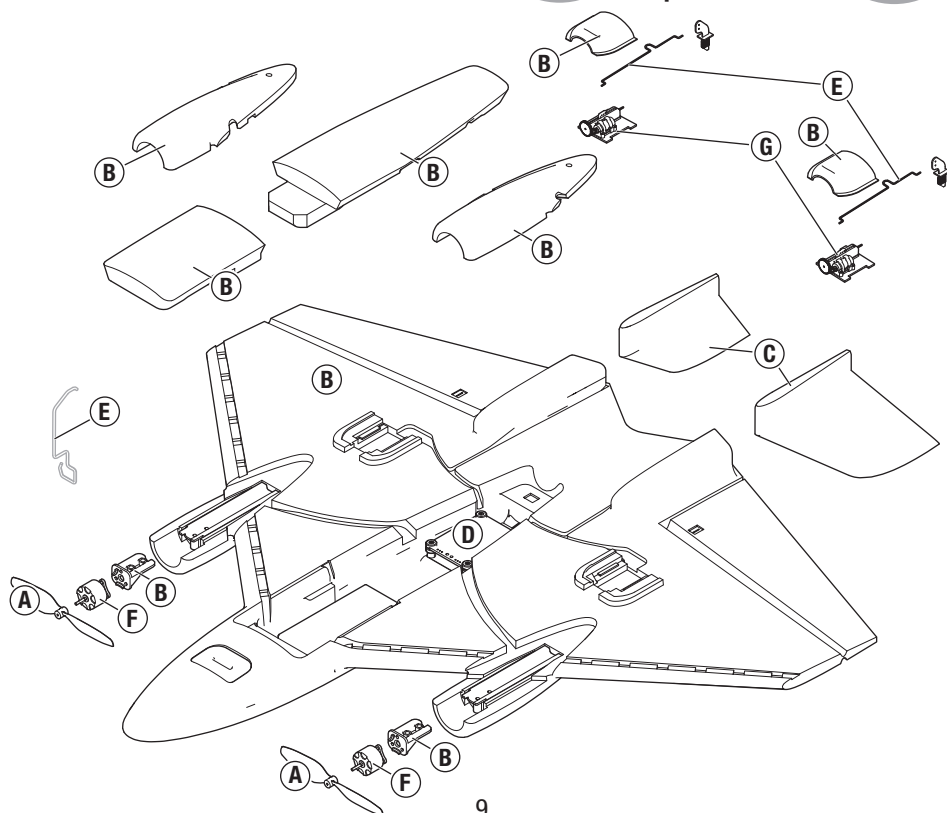
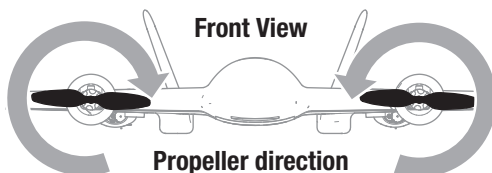

Recommended Parts List

Part #	Description
EFLB2801S25	500mAh 1S 25C Li-Po (EFLB5001S25)
SPMXC1040	S44 Micro 4-port AC/DC 1S LiPo Smart Charger

Optional Parts

Part #	Description
EFLU6455	LED Set: Ultrix

Receiver Wiring Diagram

Reference the following diagram for all wiring connections to the receiver.

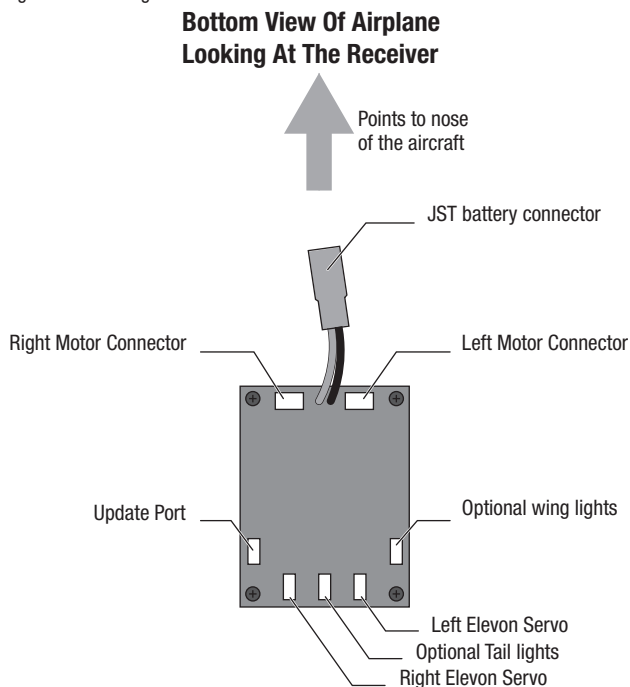

AS3X Troubleshooting Guide

Problem	Possible Cause	Solution
Control surfaces not at neutral position when transmitter controls are at neutral	Control surfaces not mechanically centered from factory	Center control surfaces mechanically by adjusting the U-bends on control linkages
	Aircraft was moved after the flight battery was connected and before sensors initialized	Disconnect and reconnect the flight battery while keeping the aircraft still for 5 seconds
Model flies inconsistently from flight to flight	Trims are moved too far from neutral position	Neutralize trims and mechanically adjust linkages to center control surfaces
Controls oscillate in flight (model rapidly jumps or moves)	Propeller is unbalanced, causing excessive vibration	Remove propeller and motor. Check motor shaft for straightness and replace prop if damaged

Troubleshooting Guide

Problem	Possible Cause	Solution
Aircraft will not respond to throttle but responds to other controls	Throttle stick and/or throttle trim too high	Reset controls with throttle stick and throttle trim at lowest setting
	Throttle channel is reversed	Reverse throttle channel on transmitter
	Motor disconnected from receiver	Open fuselage and make sure motor is connected to the receiver
Extra motor noise or extra vibration	Damaged propeller or motor	Replace damaged parts
	Propeller out of balance	Balance or replace the propeller
Reduced flight time or aircraft underpowered	Flight battery charge is low	Completely recharge flight battery
	Flight battery damaged	Replace flight battery and follow flight battery instructions
	Flight conditions may be too cold	Make sure battery is not cold before use
	Battery capacity too low for flight conditions	Replace battery or use a larger capacity battery
LED on receiver flashes and aircraft will not bind to transmitter (during binding)	Transmitter too near aircraft during binding process	Power off transmitter, move transmitter a larger distance from aircraft, disconnect and reconnect flight battery to aircraft and follow binding instructions
	Bind switch or button not held long enough during bind process	Power off transmitter and repeat bind process. Hold transmitter bind button or switch until receiver is bound
LED on receiver flashes rapidly and aircraft will not respond to transmitter (after binding)	Less than a 5-second wait between first powering on transmitter and connecting flight battery to aircraft	Leaving transmitter on, disconnect and reconnect flight battery to aircraft
	Aircraft bound to different model memory (ModelMatch™ radios only)	Select correct model memory on transmitter and disconnect and reconnect flight battery to aircraft
	Flight battery/transmitter battery charge is too low	Replace/recharge batteries
Control surface does not move	Control surface, control horn, linkage or servo damage	Replace or repair damaged parts and adjust controls
	Wire damaged or connections loose	Do a check of wires and connections, connect or replace as needed
	Flight battery charge is low	Fully recharge flight battery
	Control linkage does not move freely	Make sure control linkage moves freely
Controls reversed	Transmitter settings reversed	Adjust controls on transmitter appropriately
Motor loses power	Damage to motor or power components	Do a check of motor and power components for damage (replace as needed)
Motor power quickly decreases and increases then motor loses power	Battery power is down to the point of receiver/ESC Low Voltage Cutoff (LVC)	Recharge flight battery or replace battery that is no longer performing
Motor/ESC is not armed after landing	Over Current Protection (OCP) stops the motor when the transmitter throttle is set high and the rotor cannot turn	Fully lower throttle and throttle trim to arm ESC
Servo locks or freezes at full travel	Travel adjust value is set above 100% overdriving the servo	Set Travel adjust to 100% or less and/or set sub-trims to zero and adjust linkages mechanically

Limited Warranty

What this Warranty Covers

Horizon Hobby, LLC, (Horizon) warrants to the original purchaser that the product purchased (the "Product") will be free from defects in materials and workmanship at the date of purchase.

What is Not Covered

This warranty is not transferable and does not cover (i) cosmetic damage, (ii) damage due to acts of God, accident, misuse, abuse, negligence, commercial use, or due to improper use, installation, operation or maintenance, (iii) modification of or to any part of the Product, (iv) attempted service by anyone other than a Horizon Hobby authorized service center, (v) Product not purchased from an authorized Horizon dealer, (vi) Product not compliant with applicable technical regulations, or (vii) use that violates any applicable laws, rules, or regulations.

OTHER THAN THE EXPRESS WARRANTY ABOVE, HORIZON MAKES NO OTHER WARRANTY OR REPRESENTATION, AND HEREBY DISCLAIMS ANY AND ALL IMPLIED WARRANTIES, INCLUDING, WITHOUT LIMITATION, THE IMPLIED WARRANTIES OF NON-INFRINGEMENT, MERCHANTABILITY AND FITNESS FOR A PARTICULAR PURPOSE. THE PURCHASER ACKNOWLEDGES THAT THEY ALONE HAVE DETERMINED THAT THE PRODUCT WILL SUITABLY MEET THE REQUIREMENTS OF THE PURCHASER'S INTENDED USE.

Purchaser's Remedy

Horizon's sole obligation and purchaser's sole and exclusive remedy shall be that Horizon will, at its option, either (i) service, or (ii) replace, any Product determined by Horizon to be defective. Horizon reserves the right to inspect any and all Product(s) involved in a warranty claim. Service or replacement decisions are at the sole discretion of Horizon. Proof of purchase is required for all warranty claims. SERVICE OR REPLACEMENT AS PROVIDED UNDER THIS WARRANTY IS THE PURCHASER'S SOLE AND EXCLUSIVE REMEDY.

Limitation of Liability

HORIZON SHALL NOT BE LIABLE FOR SPECIAL, INDIRECT, INCIDENTAL OR CONSEQUENTIAL DAMAGES, LOSS OF PROFITS OR PRODUCTION OR COMMERCIAL LOSS IN ANY WAY, REGARDLESS OF WHETHER SUCH CLAIM IS BASED IN CONTRACT, WARRANTY, TORT, NEGLIGENCE, STRICT LIABILITY OR ANY OTHER THEORY OF LIABILITY, EVEN IF HORIZON HAS BEEN ADVISED OF THE POSSIBILITY OF SUCH DAMAGES.

Further, in no event shall the liability of Horizon exceed the individual price of the Product on which liability is asserted. As Horizon has no control over use, setup, final assembly, modification or misuse, no liability shall be assumed nor accepted for any resulting damage or injury. By the act of use, setup or assembly, the user accepts all resulting liability. If you as the purchaser or user are not prepared to accept the liability associated with the use of the Product, purchaser is advised to return the Product immediately in new and unused condition to the place of purchase.

Law

These terms are governed by Illinois law (without regard to conflict of law principals). This warranty gives you specific legal rights, and you may also have other rights which vary from state to state. Horizon reserves the right to change or modify this warranty at any time without notice.

WARRANTY SERVICES

Questions, Assistance, and Services

Your local hobby store and/or place of purchase cannot provide warranty support or service. Once assembly, setup or use of the Product has been started, you must contact your local distributor or Horizon directly. This will enable Horizon to better answer your questions and service you in the event that you may need any assistance. For questions or assistance,

please visit our website at www.horizonhobby.com, submit a Product Support Inquiry, or call the toll free telephone number referenced in the Warranty and Service Contact Information section to speak with a Product Support representative.

Inspection or Services

If this Product needs to be inspected or serviced and is compliant in the country you live and use the Product in, please use the Horizon Online Service Request submission process found on our website or call Horizon to obtain a Return Merchandise Authorization (RMA) number. Pack the Product securely using a shipping carton. Please note that original boxes may be included, but are not designed to withstand the rigors of shipping without additional protection. Ship via a carrier that provides tracking and insurance for lost or damaged parcels, as Horizon is not responsible for merchandise until it arrives and is accepted at our facility. An Online Service Request is available at http://www.horizonhobby.com/content/service-center_render-service-center. If you do not have internet access, please contact Horizon Product Support to obtain a RMA number along with instructions for submitting your product for service. When calling Horizon, you will be asked to provide your complete name, street address, email address and phone number where you can be reached during business hours. When sending product into Horizon, please include your RMA number, a list of the included items, and a brief summary of the problem. A copy of your original sales receipt must be included for warranty consideration. Be sure your name, address, and RMA number are clearly written on the outside of the shipping carton.

NOTICE: Do not ship LiPo batteries to Horizon. If you have any issue with a LiPo battery, please contact the appropriate Horizon Product Support office.

Warranty Requirements

For Warranty consideration, you must include your original sales receipt verifying the proof-of-purchase date. Provided warranty conditions have been met, your Product will be serviced or replaced free of charge. Service or replacement decisions are at the sole discretion of Horizon.

Non-Warranty Service

Should your service not be covered by warranty, service will be completed and payment will be required without notification or estimate of the expense unless the expense exceeds 50% of the retail purchase cost. By submitting the item for service you are agreeing to payment of the service without notification. Service estimates are available upon request. You must include this request with your item submitted for service. Non-warranty service estimates will be billed a minimum of ½ hour of labor. In addition you will be billed for return freight. Horizon accepts money orders and cashier's checks, as well as Visa, MasterCard, American Express, and Discover cards. By submitting any item to Horizon for service, you are agreeing to Horizon's Terms and Conditions found on our website http://www.horizonhobby.com/content/service-center_render-service-center.

ATTENTION: Horizon service is limited to Product compliant in the country of use and ownership. If received, a non-compliant Product will not be serviced. Further, the sender will be responsible for arranging return shipment of the un-serviced Product, through a carrier of the sender's choice and at the sender's expense. Horizon will hold non-compliant Product for a period of 60 days from notification, after which it will be discarded.

Warranty and Service Contact Information

Country of Purchase	Horizon Hobby	Contact Information	Address
United States of America	Horizon Service Center (Repairs and Repair Requests)	servicecenter.horizonhobby.com/ RequestForm/	2904 Research Rd Champaign, IL 61822
	Horizon Product Support (Product Technical Assistance)	productsupport@horizonhobby.com 877-504-0233	
	Sales	websales@horizonhobby.com 800-338-4639	
European Union	Horizon Technischer Service	service@horizonhobby.eu	Hanskampring 9 D 22885 Barsbüttel, Germany
	Sales: Horizon Hobby GmbH	+49 (0) 4121 2655 100	

FCC Information

Contains FCC ID: BRWWAC01T

This equipment has been tested and found to comply with the limits for a Class B digital device, pursuant to part 15 of the FCC Rules. These limits are designed to provide reasonable protection against harmful interference in a residential installation. This equipment generates, uses and can radiate radio frequency energy and, if not installed and used in accordance with the instructions, may cause harmful interference to radio communications.

NOTICE: Modifications to this product will void the user's authority to operate this equipment.

This product contains a radio transmitter with wireless technology which has been tested and found to be compliant with the applicable regulations governing a radio transmitter in the 2.400GHz to 2.4835GHz frequency range.

Supplier's Declaration of Conformity

Ultrix BNF Basic SAFE (EFLU6450)

FCC This device complies with part 15 of the FCC Rules. Operation is subject to the following two conditions: (1) This device may not cause harmful interference, and (2) this device must accept any interference received, including interference that may cause undesired operation.



CAUTION: Changes or modifications not expressly approved by the party responsible for compliance could void the user's authority to operate the equipment.

NOTE: This equipment has been tested and found to comply with the limits for a Class B digital device, pursuant to part 15 of the FCC Rules. These limits are designed to provide reasonable protection against harmful interference in a residential installation. This equipment generates, uses and can radiate radio frequency energy and, if not installed and used in accordance with the instructions, may cause harmful interference to radio communications. However, there is no guarantee that interference will not occur in a particular installation. If this equipment does cause harmful interference to radio or television reception, which can be determined by turning the equipment off and on, the user is encouraged to try to correct the interference by one or more of the following measures:

- Reorient or relocate the receiving antenna.
- Increase the separation between the equipment and receiver.
- Connect the equipment into an outlet on a circuit different from that to which the receiver is connected.
- Consult the dealer or an experienced radio/TV technician for help.

Horizon Hobby, LLC
2904 Research Rd
Champaign, IL 61822
Email: compliance@horizonhobby.com
Web: HorizonHobby.com

IC Information

Contains IC: 6157A-WAC01T

CAN ICES-3 (B)/NMB-3(B) This device complies with Industry Canada licence-exempt RSS standard(s). Operation is subject to the following two conditions:

(1) this device may not cause interference, and (2) this device must accept any interference, including interference that may cause undesired operation of the device.

Compliance Information for the European Union



EU Compliance Statement:

Ultrix BNF Basic SAFE (EFLU6450)

Horizon Hobby, LLC hereby declares that this product is in compliance with the essential requirements and other relevant provisions of the RED and EMC Directive.

A copy of the EU Declaration of Conformity is available online at:
<http://www.horizonhobby.com/content/support-render-compliance>.

Instructions for disposal of WEEE by users in the European Union



This product must not be disposed of with other waste. Instead, it is the user's responsibility to dispose of their waste equipment by handing it over to a designated collections point for the recycling of waste electrical and electronic equipment. The separate collection and recycling of your waste equipment at the time of disposal will help to conserve natural resources and ensure that it is recycled in a manner that protects human health and the environment. For more information about where you can drop off your waste equipment for recycling, please contact your local city office, your household waste disposal service or where you purchased the product.



E328



© 2019 Horizon Hobby, LLC.

E-flite, UMX, SAFE, the SAFE logo, AS3X, DSM, DSM2, DSMX, Bind-N-Fly, BNF, the BNF logo, ModelMatch, Celectra, Delta-V, and the Horizon Hobby logo are trademarks or registered trademarks of Horizon Hobby, LLC.

The Spektrum trademark is used with permission of Bachmann Industries, Inc. All other trademarks, service marks and logos are property of their respective owners.

US 8,672,726. US 9,930,567. US 10,419,970. US 9,056,667. US 9,753,457. US 10,078,329. US 7,898,130. D578,146. PRC ZL 200720069025. PRC ZL 2007001249.

www.horizonhobby.com