

Name: _____		Date: _____		Event: _____	
City: _____		State: _____		Track: _____	
Track Conditions	<input type="checkbox"/> Indoor	<input type="checkbox"/> Tight	<input type="checkbox"/> Smooth	<input type="checkbox"/> Hard Packed	<input type="checkbox"/> Blue Groove
	<input type="checkbox"/> Outdoor	<input type="checkbox"/> Open	<input type="checkbox"/> Rough	<input type="checkbox"/> Loose/Loamy	<input type="checkbox"/> Dry
				<input type="checkbox"/> Wet	<input type="checkbox"/> Grass
				<input type="checkbox"/> Dusty	<input type="checkbox"/> Astro Turf
					<input type="checkbox"/> Low Bite
					<input type="checkbox"/> High Bite
					<input type="checkbox"/> Med Bite
					<input type="checkbox"/> Other _____

Front Suspension

Toe: _____

Ride Height: _____

Camber: _____

Caster: 10° 15° 20°

Sway Bar: _____

Oil: _____

Piston: _____

Spring: Standard Low Freq. Color: _____

Shock Limiters: _____

Shock Location: _____

Bump Steer Ball Stud: Standard Low Mount

Bumper Steer Spacers: _____

Camber Link: _____

Ackermann: _____

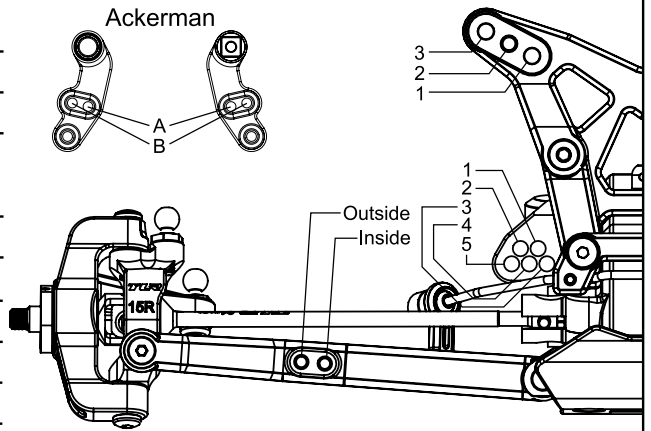

Notes: _____

Rear Suspension

Toe: _____

Anti-Squat: _____

Roll Center: Low Roll Center (LRC) High Roll Center (HRC)

Ride Height: _____

Camber: _____

Rear Hub Spacing: _____

Hex Width: _____

Sway Bar: _____

Oil: _____

Piston: _____

Spring: Standard Low Freq. Color: _____

Shock Limiters: _____

Camber Link: _____

Shock Locations: _____

Wing/Wickerbill: _____

Battery Position: _____

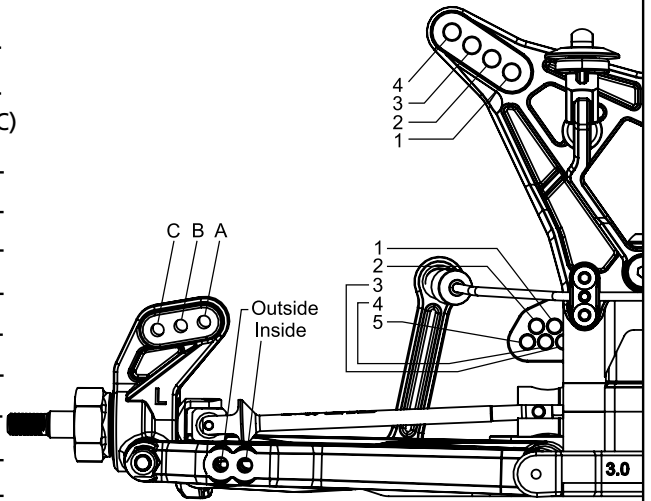

Electronics

Radio: _____

Servo: _____

ESC: _____

Initial Brake: _____

Drag Brake: _____

Throttle Profile: _____

Timing Advance: _____

Throttle/Brake Expo: _____

Servo Expo: _____

Throttle/Brake EPA: _____

Motor: _____

Pinion: _____ Spur: _____

Battery: _____

Tires	Compound	Insert	Additive
Front: _____	_____	_____	_____
Rear: _____	_____	_____	_____
Notes: _____			