

axial®

WWW.AXIALADVENTURE.COM

1/18th SCALE READY-TO-RUN



AXI01002

UTB18™ Capra™



**INSTRUCTION MANUAL
BEDIENUNGSANLEITUNG
MANUEL D'UTILISATION
MANUALE DI ISTRUZIONI**

Scan the QR code and select the Manuals and Support quick links from the product page for the most up-to-date manual information.

Scannen Sie den QR-Code und wählen Sie auf der Produktseite die Quicklinks Handbücher und Unterstützung, um die aktuellsten Informationen zu Handbücher.

Scannez le code QR et sélectionnez les liens rapides Manuals and Support sur la page du produit pour obtenir les informations les plus récentes sur le manuel.

Scannerizzare il codice QR e selezionare i Link veloci Manuali e Supporto dalla pagina del prodotto per le informazioni manuali più aggiornate.

HORIZON®
H O B B Y

NOTICE

All instructions, warranties and other collateral documents are subject to change at the sole discretion of Horizon Hobby, LLC. For up-to-date product literature, visit horizonhobby.com or towerhobbies.com and click on the support or resources tab for this product.

MEANING OF SPECIAL LANGUAGE

The following terms are used throughout the product literature to indicate various levels of potential harm when operating this product:

WARNING: Procedures, which if not properly followed, create the probability of property damage, collateral damage, and serious injury OR create a high probability of superficial injury.

CAUTION: Procedures, which if not properly followed, create the probability of physical property damage AND a possibility of serious injury.

NOTICE: Procedures, which if not properly followed, create a possibility of physical property damage AND a little or no possibility of injury.

 **WARNING:** Read the ENTIRE instruction manual to become familiar with the features of the product before operating. Failure to operate the product correctly can result in damage to the product, personal property and cause serious injury.

This is a sophisticated hobby product. It must be operated with caution and common sense and requires some basic mechanical ability. Failure to operate this Product in a safe and responsible manner could result in injury or damage to the product or other property. This product is not intended for use by children without direct adult supervision. Do not use with incompatible components or alter this product in any way outside of the instructions provided by Horizon Hobby, LLC. This manual contains instructions for safety, operation and maintenance. It is essential to read and follow all the instructions and warnings in the manual, prior to assembly, setup or use, in order to operate correctly and avoid damage or serious injury.

Age Recommendation: Not for children under 14 years. This is not a toy.

SAFETY PRECAUTIONS AND WARNINGS

As the user of this product, you are solely responsible for operating in a manner that does not endanger yourself and others or result in damage to the product or property of others.

This model is controlled by a radio signal subject to interference from many sources outside your control. This interference can cause momentary loss of control, so it is advisable to always keep a safe distance in all directions around your model as this margin will help avoid collisions or injury.

- Never operate your model with low transmitter batteries.
- Always operate your model in open spaces away from full-size vehicles, traffic and people.
- Never operate the model in the street or in populated areas for any reason.
- Carefully follow the directions and warnings for this and any optional support equipment (chargers, rechargeable battery packs, etc.) you use.
- Keep all chemicals, small parts and anything electrical out of the reach of children.
- Never lick or place any portion of the model in your mouth as it could cause serious injury or even death.
- Exercise caution when using tools and sharp instruments.
- Take care during maintenance as some parts may have sharp edges.
- Immediately after using your model, do NOT touch equipment such as the motor, electronic speed control and battery, because they generate high temperatures. You may burn yourself seriously touching them.
- Do not put fingers or any objects inside rotating and moving parts, as this may cause damage or serious injury.
- Always turn on your transmitter before you turn on the receiver in the car. Always turn off the receiver before turning your transmitter off.
- Keep the wheels of the model off the ground when checking the operation of the radio equipment.

 **WARNING AGAINST COUNTERFEIT PRODUCTS:** Always purchase from a Horizon Hobby, LLC authorized dealer to ensure authentic high-quality Spektrum product. Horizon Hobby, LLC disclaims all support and warranty with regards, but not limited to, compatibility and performance of counterfeit products or products claiming compatibility with DSM® or Spektrum technology.

TABLE OF CONTENTS

Water-resistant Vehicle with Waterproof Electronics	3	Warranty and Service Contact Information	11
Charging Warnings.....	3	FCC Information.....	12
Box Contents.....	4	IC Information.....	12
Recommended Tools	4	Compliance Information for the European Union.....	12
Getting Started Checklist.....	5	Exploded Views	13
Vehicle Parts.....	5	Parts Lists	17
Install the Transmitter Batteries.....	6	Electronics	18
Transmitter Functions.....	6	Recommended Parts.....	18
Charging the Battery	6	Optional Parts.....	18
Install the Vehicle Battery	7	Exploded Views.....	46
Range-Checking the Radio System	8	Parts Lists.....	50
Vehicle Maintenance	8	Electronics	51
2 in 1 Brushed ESC and SLT Receiver	9	Recommended Parts.....	51
Troubleshooting.....	10	Optional Parts.....	51
Limited Warranty.....	11		

WATER-RESISTANT VEHICLE WITH WATERPROOF ELECTRONICS

Your new Horizon Hobby vehicle has been designed and built with a combination of waterproof and water-resistant components to allow you to operate the product in many “wet conditions,” including puddles, creeks, wet grass, snow and even rain.

While the entire vehicle is highly water-resistant, it is not completely waterproof and your vehicle should NOT be treated like a submarine. The various electronic components used in the vehicle, such as the Electronic Speed Control (ESC), servo(s) and receiver are waterproof, however, most of the mechanical components are water-resistant and should not be submerged.

Metal parts, including the bearings, hinge pins, screws and nuts, as well as the contacts in the electrical cables, will be susceptible to corrosion if additional maintenance is not performed after running in wet conditions. To maximize the long-term performance of your vehicle and to keep the warranty intact, the procedures described in the “Wet Conditions Maintenance” section below must be performed regularly if you choose to run in wet conditions. If you are not willing to perform the additional care and maintenance required, then you should not operate the vehicle in those conditions.

 **CAUTION:** Failure to exercise caution while using this product and complying with the following precautions could result in product malfunction and/or void the warranty.

GENERAL PRECAUTIONS

- Read through the wet conditions maintenance procedures and make sure that you have all the tools you will need to properly maintain your vehicle.
- Not all batteries can be used in wet conditions. Consult the battery manufacturer before use. Caution should be taken when using Li-Po batteries in wet conditions.
- Most transmitters are not water-resistant. Consult your transmitter’s manual or the manufacturer before operation.
- Never operate your transmitter or vehicle where lightning may be present.
- Do not operate your vehicle where it could come in contact with salt water (ocean water or water on salt-covered roads), contaminated or polluted water. Salt water is very conductive and highly corrosive, so use caution.

CHARGING WARNINGS

 **CAUTION:** All instructions and warnings must be followed exactly. Mishandling of Li-Po batteries can result in a fire, personal injury and/or property damage.

NEVER LEAVE CHARGING BATTERIES UNATTENDED.

NEVER CHARGE BATTERIES OVERNIGHT.

By handling, charging or using the included Li-Po battery, you assume all risks associated with lithium batteries.

If at any time the battery begins to balloon or swell, discontinue use immediately. If charging or discharging, discontinue and disconnect. Continuing to use, charge or discharge a battery that is ballooning or swelling can result in fire.

Always store the battery at room temperature in a dry area for best results.

Always transport or temporarily store the battery in a temperature range of 40–120° F (5–49° C).

Do not store battery or model in a car or direct sunlight. If stored in a hot car, the battery can be damaged or even catch fire.

- Even minimal water contact can reduce the life of your motor if it has not been certified as water-resistant or waterproof. If the motor becomes excessively wet, apply very light throttle until the water is mostly removed from the motor. Running a wet motor at high speeds may rapidly damage the motor.
- Driving in wet conditions can reduce the life of the motor. The additional resistance of operating in water causes excess strain. Alter the gear ratio by using a smaller pinion or larger spur gear. This will increase torque (and motor life) when running in mud, deeper puddles, or any wet conditions that will increase the load on the motor for an extended period of time.

WET CONDITIONS MAINTENANCE

- Drain any water that has collected in the tires by spinning them at high speed. With the body removed, place the vehicle upside down and pull full throttle for a few short bursts until the water has been removed.

 **CAUTION:** Always keep hands, fingers, tools and any loose or hanging objects away from rotating parts when performing the above drying technique.

- Remove the battery pack(s) and dry the contacts. If you have an air compressor or a can of compressed air, blow out any water that may be inside the recessed connector housing.
- Remove the tires/wheels from the vehicle and gently rinse the mud and dirt off with a garden hose. Avoid rinsing the bearings and transmission.

NOTICE: Never use a pressure washer to clean your vehicle.

- Use an air compressor or a can of compressed air to dry the vehicle and help remove any water that may have gotten into small crevices or corners.
- Spray the bearings, drive train, fasteners and other metal parts with a water-displacing light oil. Do not spray the motor.
- Let the vehicle air dry before you store it. Water (and oil) may continue to drip for a few hours.
- Increase the frequency of disassembly, inspection and lubrication of the following:
 - Front and rear axle hub assembly bearings.
 - All transmission cases, gears and differentials.
 - Motor—clean with an aerosol motor cleaner and re-oil the bushings with lightweight motor oil.

Always charge batteries away from flammable materials.

Always inspect the battery before charging.

Always disconnect the battery after charging, and let the charger cool between charges.

Always constantly monitor the temperature of the battery pack while charging.

ONLY USE A CHARGER SPECIFICALLY DESIGNED TO CHARGE LI-PO BATTERIES. Failure to charge the battery with a compatible charger may cause a fire resulting in personal injury and/or property damage.

Never discharge Li-Po cells to below 3V under load.

Never cover warning labels with hook and loop strips.

Never charge batteries outside recommended levels.

Never charge damaged batteries.

Never attempt to dismantle or alter the charger.

Never allow minors to charge battery packs.

Never charge batteries in extremely hot or cold places (recommended between 40–120° F or [5–49° C]) or place in direct sunlight.

BOX CONTENTS

- Spektrum™ SLT2 2 Channel 2.4GHz Transmitter (SPMRSLT200F)
 - (4) AA Alkaline batteries
- Capra™ UTB18 RTR
 - Tazer 37-Turn 380 Brushed Motor (DYNS1208)
 - 2 in 1 Brushed ESC and SLT Receiver (SPMXSE2525RX)
 - Servo (SPMS651)
 - 7.4V 650mAh 2S 20C LiPo, Hard (DYNB65021H2)
- USB LiPo Charger (DYNC1063)

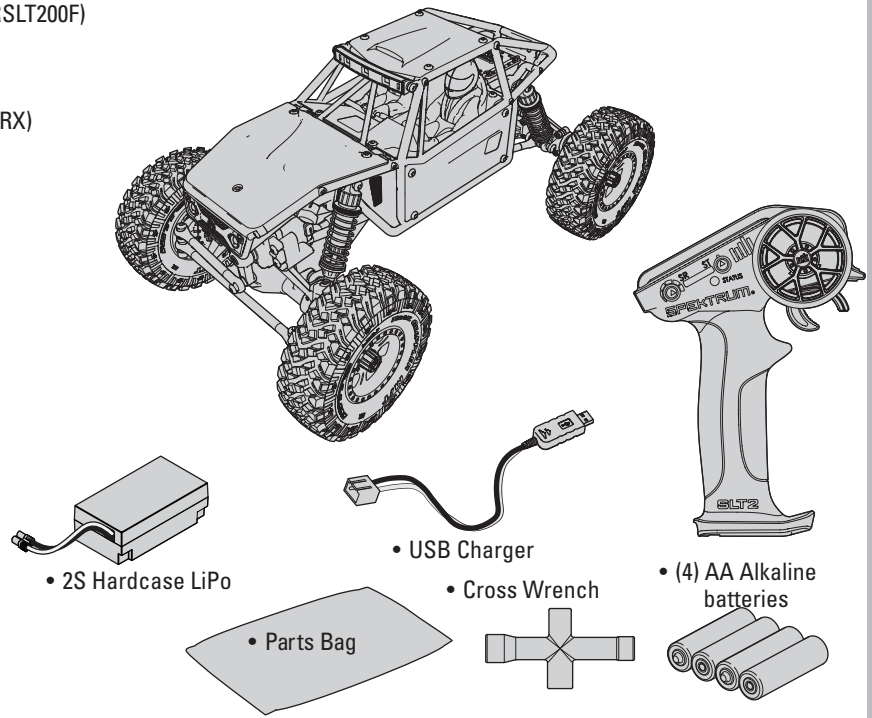

RECOMMENDED TOOLS

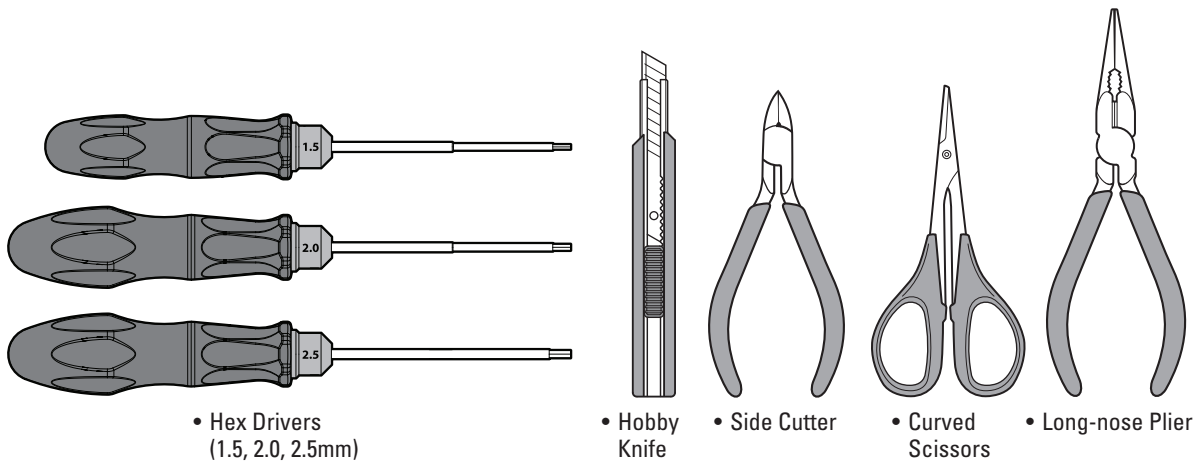

GETTING STARTED CHECKLIST

Read the manual
Familiarize yourself with the vehicle and its components
Check all screws, especially the driveshaft setscrews, for tightness from the factory
Charge the vehicle battery
Install 4 AA batteries in the transmitter

Power on the transmitter
Install the vehicle battery in the vehicle
Check for proper function of the throttle and steering
Range check the radio system
Drive the vehicle, challenge yourself and have FUN!
Perform any necessary vehicle maintenance

VEHICLE PARTS

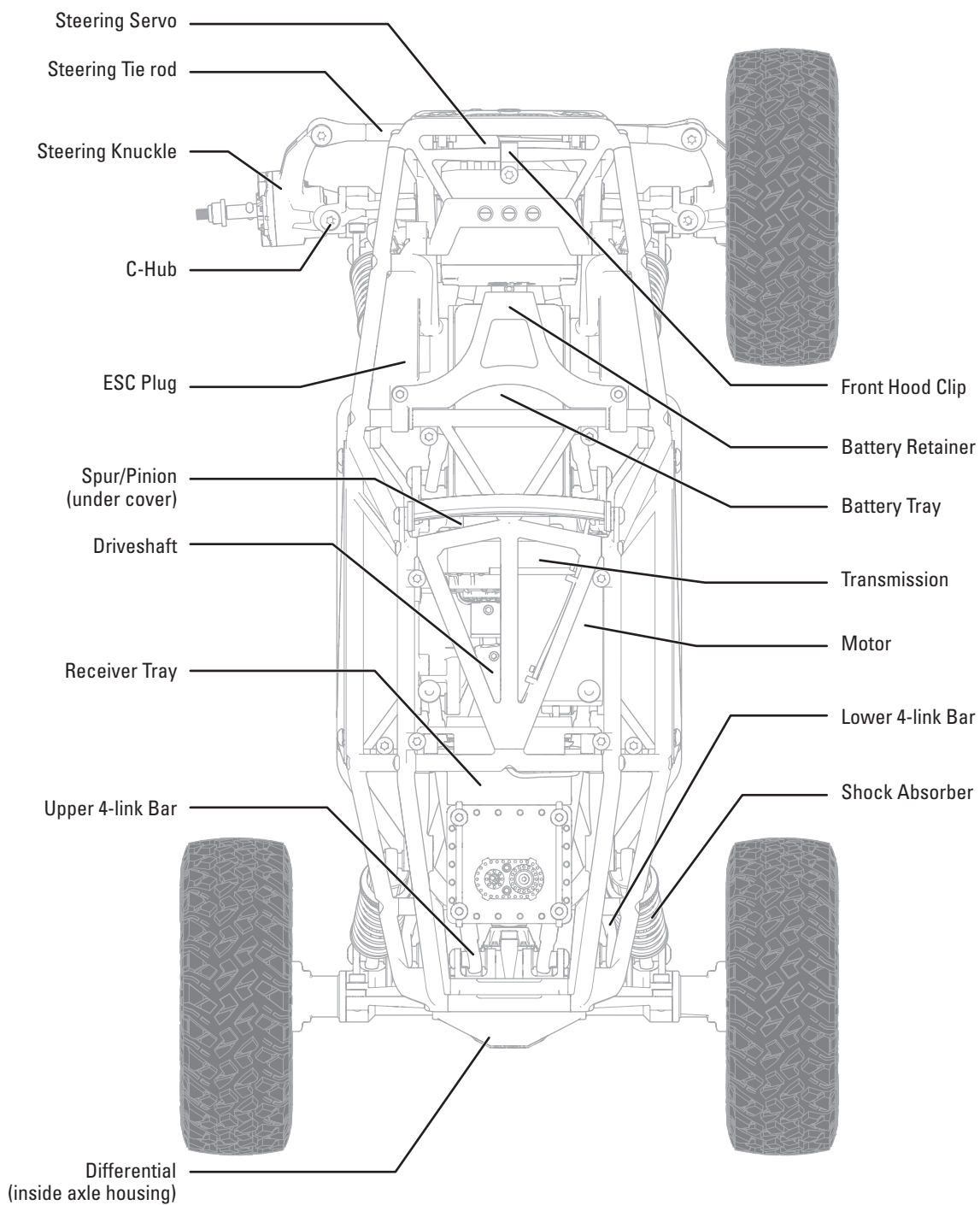

INSTALL THE TRANSMITTER BATTERIES

This transmitter requires 4 AA batteries.

1. Remove the battery cover from the transmitter.
2. Install the **included** AA batteries as shown.
3. Install the battery cover.

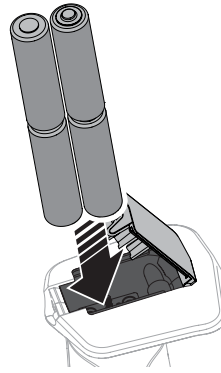

- CAUTION:** NEVER remove the transmitter batteries while the model is powered on. Loss of model control, damage, or injury may occur.
- CAUTION:** If using rechargeable batteries, charge only rechargeable batteries. Charging non-rechargeable batteries may cause the batteries to burst, resulting in injury to persons and/or damage to property.
- CAUTION:** Risk of explosion if battery is replaced by an incorrect type. Dispose of used batteries according to national regulations.

TRANSMITTER FUNCTIONS

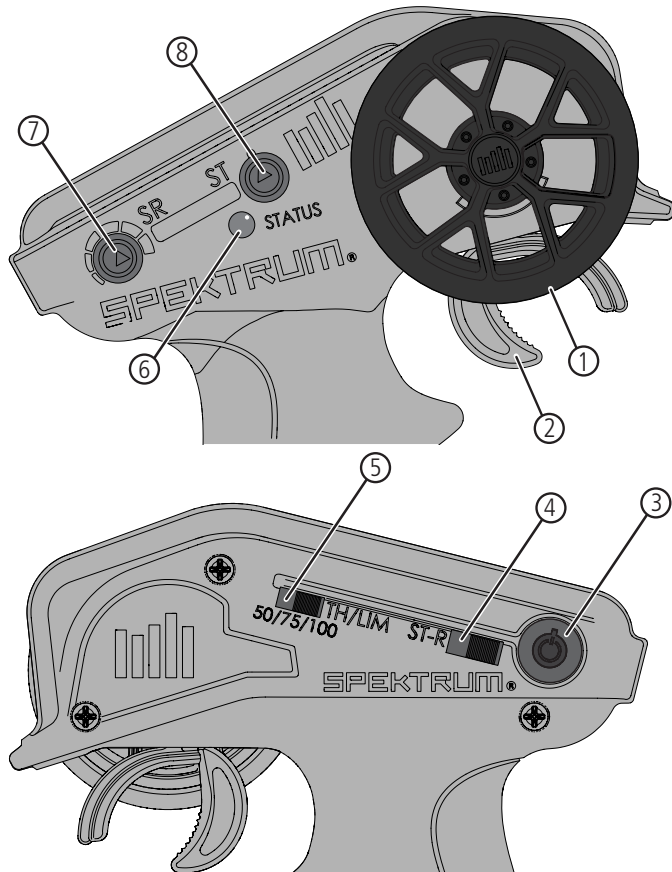

- 1. Steering Wheel** Controls direction (left/right) of the model
- 2. Throttle Trigger** Controls speed and direction (forward/brake/reverse) of the model
- 3. Power Button** Turns the power on/off
- 4. Steering (ST-R) Servo Reversing** Reverses the steering channel
- 5. Throttle Limit** Limits throttle output to 50/75/100%
Select 50% or 75% for less experienced drivers or when you are driving the vehicle in a small area
- 6. Indicator Lights**
Solid red light—Indicates radio connectivity and adequate battery power
Flashing red light—Indicates the battery voltage is critically low. Replace the batteries
- 7. Steering Rate** Adjusts the steering end points
- 8. Steering Trim** Adjusts the steering center point

CHARGING THE BATTERY

- NOTICE:** Charge only batteries that are cool to the touch and are not damaged. Inspect the battery to make sure it is not damaged e.g., swollen, bent, broken or punctured.
- CAUTION:** Only use chargers specifically designed to charge the included Li-Po battery. Failure to do so could result in fire, causing injury or property damage.
- CAUTION:** Never exceed the recommended charge rate. Use only the included USB charger to charge the battery.

1. Connect the charger to a suitable USB power port. The charger will work with most 5V mobile power sources or smartphone chargers with at least 1 amp of power output.

NOTICE: Charging the battery with a USB power port with less than 1 amp of power output can produce heat.

2. Connect the charge lead to the battery, noting correct polarity. Charging a fully discharged battery takes approximately 45–60 minutes. Charge times may vary depending on the power source.
3. Remove the battery from the charger when the charging cycle is complete.
4. Remove the charger from the power supply.

- CAUTION:** Once charging is complete, immediately remove the battery.
Never leave a battery connected to the charger.

Charger LED Indications

RED, solid = Charging
RED, solid; GREEN, flashing = Stand by
GREEN, solid = Charging complete

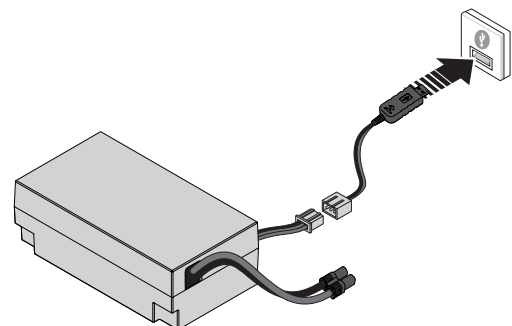

INSTALL THE VEHICLE BATTERY

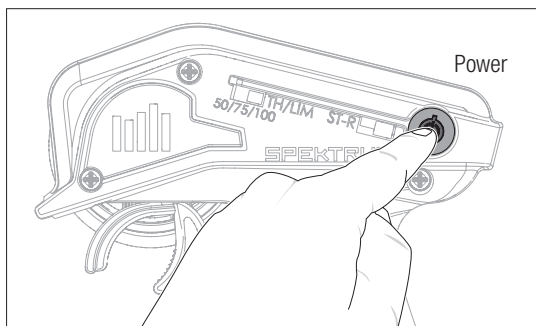

1. Power on the transmitter.
2. Press up on the hood from behind the front bumper to release the hood latch. Raise the hood.
3. Connect the battery to the ESC.

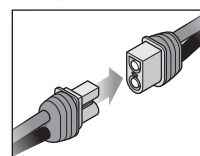
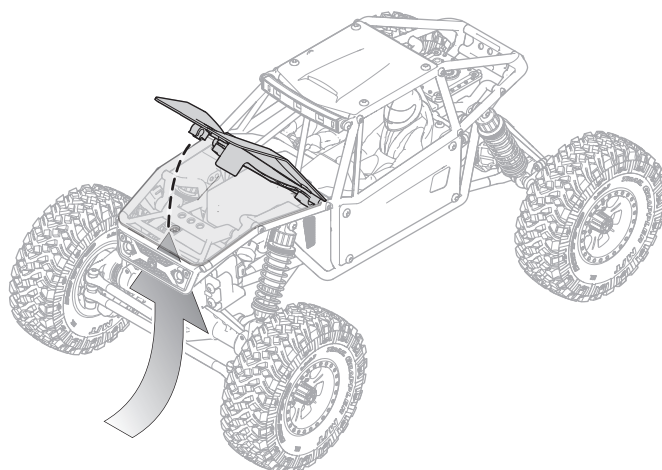

4. Place the battery in the battery tray.

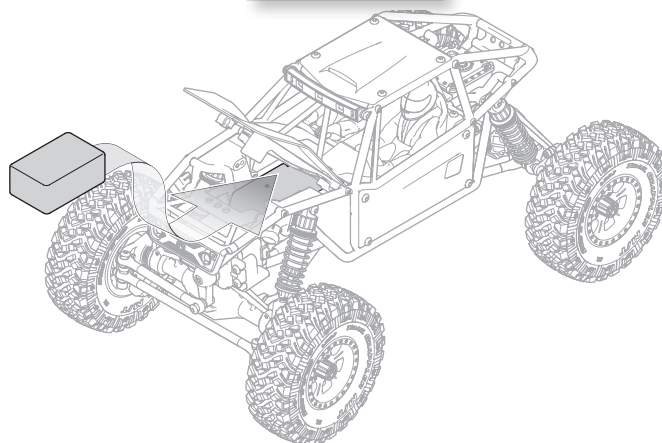

5. Close the hood and press down on the center to latch it to the chassis. The battery is secured in place by the hood.

NOTICE: Always disconnect the battery from the ESC before powering off the transmitter. Loss of vehicle control may result.

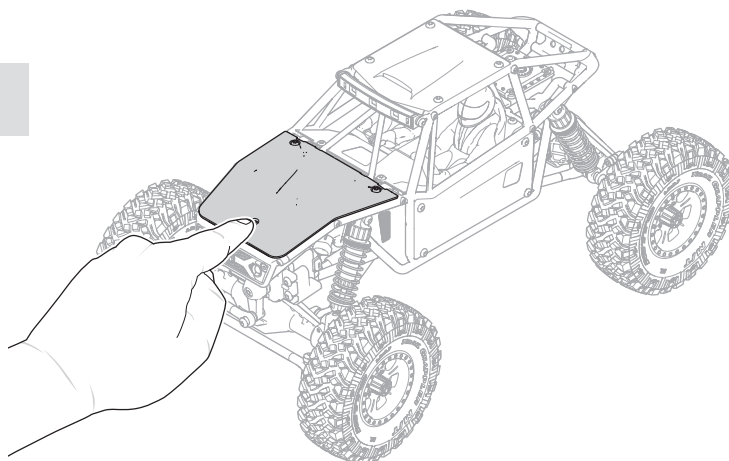

RANGE-CHECKING THE RADIO SYSTEM

The radio system should be checked before operating the vehicle to ensure proper operation and adequate range.

1. Turn on the transmitter.
2. Connect the battery in the vehicle.
3. Have a friend hold the vehicle while keeping hands and loose clothing away from moving parts.
4. Walk away until you are at the maximum planned operating distance from the vehicle.
5. Turn the steering wheel side to side and operate the throttle, both forward and reverse, checking for any erratic behavior.
6. If any erratic behavior is exhibited, DO NOT operate the vehicle. Call customer service for assistance.

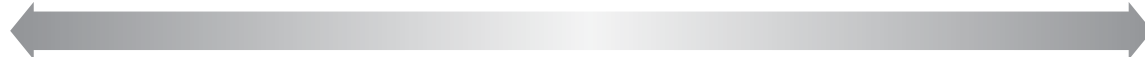
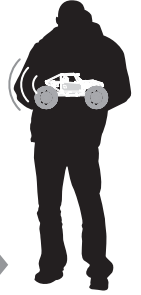

VEHICLE MAINTENANCE

Just like a full size car or truck your RC vehicle must undergo periodic maintenance in order to ensure peak performance. Preventative maintenance will also help avoid needless breakages which could result in costly repairs. Below are some suggestions to properly maintain your vehicle.

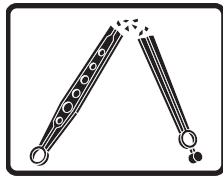
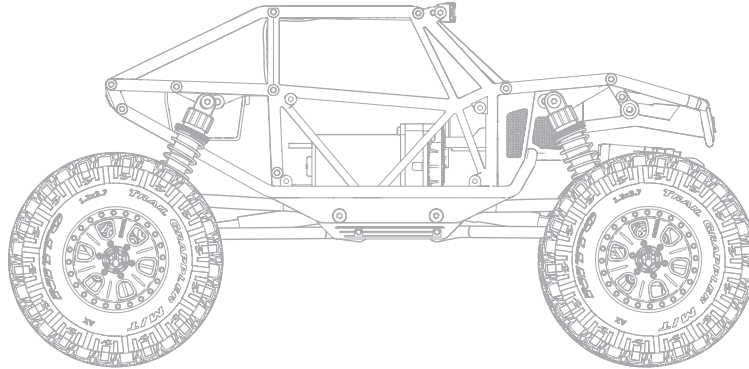

Replace any noticeable bent or broken parts

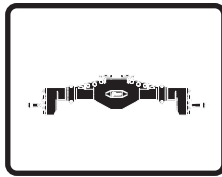

Check for wear on the ball joints in the steering and suspension links (replace if necessary)

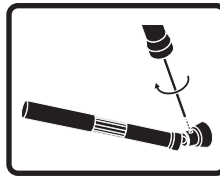

Check driveshaft set screws and apply thread locking compound if necessary

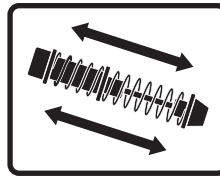

Inspect shock absorbers for smooth dampened operation

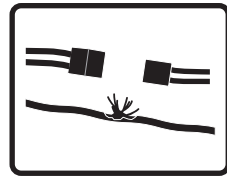

Check for any loose connections or frayed wiring

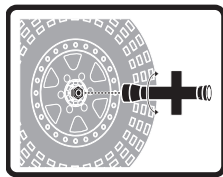

Check the wheel nuts for tightness

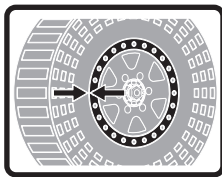

Ensure the wheel beads are still firmly bonded around the entire circumference of the rim

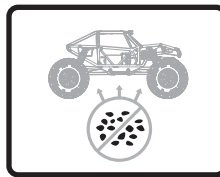

Keep the chassis free of dirt and debris

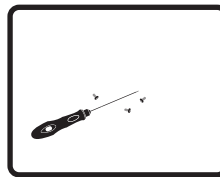

Check for loose screws on the chassis, especially the knuckle, C-hub and axle lockout screws

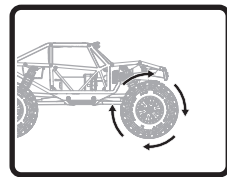

Check the driveline for smooth, bind free operation

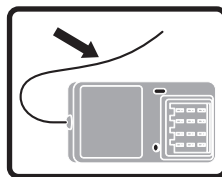

Check the receiver antenna for damage

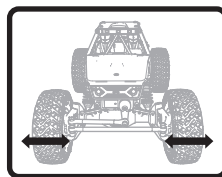

Check the steering operation for any binding

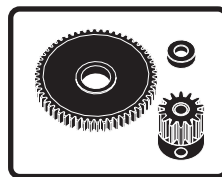

Inspect the spur and pinion gears for damage

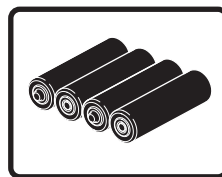

Replace the transmitter batteries when indicated by the transmitter, as described in the Transmitter Functions section

2 IN 1 BRUSHED ESC AND SLT RECEIVER

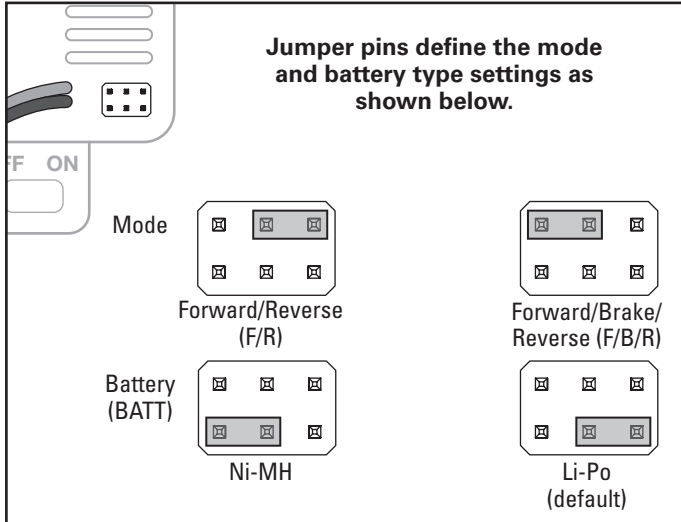
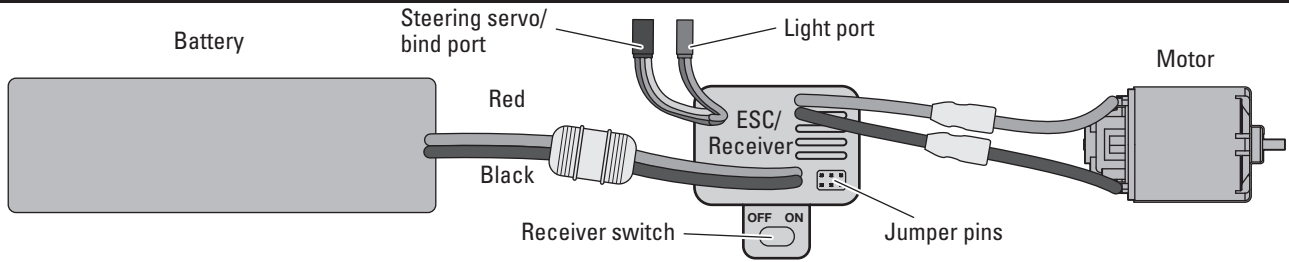

SPECIFICATIONS	
Type	2 in 1 Brushed ESC with integrated SLT receiver
Constant/Peak	25A/100A
Function	Brushed ESC, Steering servo connector, Light connector
Vehicle Type	1/18 rock crawler, 380 motor
Operation	Proportional forward and reverse
Battery Type/ Input Voltage	5-8.4V 2 cell Li-Po/Li-Fe; 6 cell Ni-MH/Ni-Cd
Motor Type	2S Li-Po down to 12T
BEC Output	6V/3A
Dimensions	36mm x 25mm x 15mm (1.8 x 1.3 x 1.1 in)
Weight	40g (1.41 oz)
Battery Connector	IC3™ connector

SETUP

Throttle calibration should not be needed out of the box. However, in order to make the throttle range of different transmitters, the calibration of the ESC is necessary:

- Mount the ESC in an area that is well ventilated and isolated from vibration and shock.
- Connect the ESC motor wires to the motor red-to-red and black-to-black.
- Before plugging the battery into the ESC, make sure your transmitter is on and the throttle trim is set to zero.
- Connect the battery to the ESC. The vehicle will be powered on when the battery is connected.

CAUTION: Keep all body parts and loose clothing away from any moving parts while the battery is connected to the ESC.

CAUTION: Always connect the ESC only to a proper power source that has the correct voltage and polarity. Incorrect voltages or reversed polarity will damage the ESC. Damage to the ESC caused by improper voltage or polarity is not covered under warranty.

- Test forward and reverse control using the transmitter.

BINDING

Binding is the process of programming the receiver to recognize the GUID (Globally Unique Identifier) code of a single specific transmitter.

The transmitter and receiver are bound at the factory. If you need to rebind, follow the instructions below:

1. Unplug the servo from 2-in-1 Spektrum servo lead.
2. Plug the bind plug into 2-in-1 Spektrum servo lead.
3. Connect a fully charged battery to the ESC.
4. Power ON the ESC
5. Power ON the transmitter. The receiver's red LED will turn solid when the bind is successful.
6. Remove the bind plug from 2-in-1 Spektrum servo lead.
7. Plug servo back into 2-in-1 Spektrum servo lead.
8. Power OFF the ESC to save the settings.
9. Power OFF the transmitter.

SOUND INDICATOR	
OPERATION	SOUND
Ni-MH/Ni-CD Battery	1 Short Beep
2S Li-Po Battery	2 Short Beeps
ESC Ready	1 Long Beep

TO CALIBRATE THE ESC:

- Power the transmitter on and set the throttle control to neutral.
- Connect the battery to the ESC and wait 3 seconds to let the ESC initiate a self-test and automatic throttle calibration.
- The ESC is ready to run when a long beep sound is emitted from the motor.
- Always disconnect the battery when the vehicle is not in use.

IMPORTANT: The LiPo cut-off is set to "ON" and the drag brake is set to 100% from the factory.

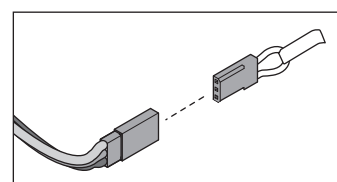
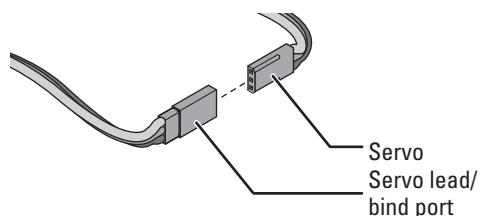

Insert the bind plug into the servo lead/bind port

TROUBLESHOOTING

PROBLEM	POSSIBLE CAUSE	SOLUTION
The system will not connect	Your transmitter and receiver are too close together	Move transmitter 8 to 12 feet away from receiver
	You are near metal objects	Move to an area with less metal
	The receiver is bound to a different model memory	Make sure the correct model memory is active in your transmitter
	Your transmitter was placed into bind mode and is no longer bound to your receiver	Rebind your transmitter and receiver, and then re-calibrate
The receiver goes into failsafe a short distance away from the transmitter	Check for damage on the receiver antenna	Make sure your receiver antenna is protected and located as high as practical Replace the receiver or contact Horizon Product Support
	Low receiver battery voltage. If the battery voltage is low, it may drop below 3.5V momentarily, causing the receiver to brown-out, then reconnect	Charge the receiver or vehicle battery. Spektrum receivers require at least 3.5V to operate
The receiver stops responding during operation	Loose or damaged wires or connectors between battery and receiver	Check the wires and connection between the battery and receiver. Repair or replace wires and/or connectors
	Batteries are not installed properly in the transmitter	Ensure the transmitter batteries are properly installed
Vehicle does not move	Weak or no battery in the vehicle	Install a freshly charged vehicle battery
	Damaged motor	Replace the motor
	Frayed or broken wiring	Replace any damaged wiring
	ESC is shut down by heat protection circuit	Allow the ESC to cool down completely
Loss of vehicle control	Improper antenna placement	Ensure the transmitter antenna is not blocked and the receiver antenna is located properly
	Weak or no batteries in the transmitter or vehicle	Install a freshly charged vehicle battery and new transmitter batteries
	Neutral or trim position is incorrect	Adjust the steering trim
	Receiver and/or battery not connected properly	Check all receiver and battery connections
Steering and/or throttle function is reversed	Servo travel is reversed at the transmitter	Set the transmitter servo reversing switch to the correct position
	Motor wires are not connected properly	Check all motor wires for correct polarity and secure connection
ESC ON - No motor function, audible tone or LED	Battery/connection issue	Recharge/replace battery. Secure all connections
	Damaged ESC	Repair/replace ESC
	Damaged motor	Repair/replace
Motor- Stops and LED blinks	Low voltage protection	When the ESC LED blinks, recharge/replace battery
	Overheat protection	When the LED blinks, let motor/ESC cool, change set up or gearing to avoid overheating
Motor- Accelerates irregularly	Battery issue	Repair damaged wiring/replace battery
	Incorrect gearing	Adjust/replace gearing
	Worn or damaged motor	Repair/replace motor
Motor- Does not turn continuously in response to throttle	ESC/motor damaged	Repair/replace wiring or motor/ESC
Motor- Slows but will not stop	Incorrect transmitter/ESC calibration	Adjust throttle travel/other throttle settings on the transmitter/ESC. Repeat the ESC Calibration Procedure
Steering servo- Operates; motor does not run	Damaged motor	Test the motor apart from the vehicle system, repair/replace motor as needed
	Incorrect transmitter/ESC calibration	Adjust throttle travel/other throttle settings on the transmitter/ESC. Repeat the ESC Calibration Procedure
Steering/motor- not functioning	Low battery voltage	Recharge/replace
	Wrong model memory selected on transmitter	Select correct model settings on your transmitter, refer to transmitter and/or receiver manual
	Receiver not bound to transmitter	Bind transmitter to receiver, refer to transmitter and/or receiver manual
Vehicle- Does not operate at full speed	Battery issue	Recharge/replace
	Incorrect transmitter/ESC calibration	Adjust throttle travel/other throttle settings on the transmitter/ESC. Repeat the ESC Calibration Procedure

LIMITED WARRANTY

What this Warranty Covers

Horizon Hobby, LLC, (Horizon) warrants to the original purchaser that the product purchased (the "Product") will be free from defects in materials and workmanship for a period of 2 years from the date of purchase.

What is Not Covered

This warranty is not transferable and does not cover (i) cosmetic damage, (ii) damage due to acts of God, accident, misuse, abuse, negligence, commercial use, or due to improper use, installation, operation or maintenance, (iii) modification of or to any part of the Product, (iv) attempted service by anyone other than a Horizon Hobby authorized service center, (v) Product not purchased from an authorized Horizon dealer, or (vi) Product not compliant with applicable technical regulations or (vii) use that violates any applicable laws, rules, or regulations.

OTHER THAN THE EXPRESS WARRANTY ABOVE, HORIZON MAKES NO OTHER WARRANTY OR REPRESENTATION, AND HEREBY DISCLAIMS ANY AND ALL IMPLIED WARRANTIES, INCLUDING, WITHOUT LIMITATION, THE IMPLIED WARRANTIES OF NON-INFRINGEMENT, MERCHANTABILITY AND FITNESS FOR A PARTICULAR PURPOSE. THE PURCHASER ACKNOWLEDGES THAT THEY ALONE HAVE DETERMINED THAT THE PRODUCT WILL SUITABLY MEET THE REQUIREMENTS OF THE PURCHASER'S INTENDED USE.

Purchaser's Remedy

Horizon's sole obligation and purchaser's sole and exclusive remedy shall be that Horizon will, at its option, either (i) service, or (ii) replace, any Product determined by Horizon to be defective. Horizon reserves the right to inspect any and all Product(s) involved in a warranty claim. Service or replacement decisions are at the sole discretion of Horizon. Proof of purchase is required for all warranty claims. SERVICE OR REPLACEMENT AS PROVIDED UNDER THIS WARRANTY IS THE PURCHASER'S SOLE AND EXCLUSIVE REMEDY.

Limitation of Liability

HORIZON SHALL NOT BE LIABLE FOR SPECIAL, INDIRECT, INCIDENTAL OR CONSEQUENTIAL DAMAGES, LOSS OF PROFITS OR PRODUCTION OR COMMERCIAL LOSS IN ANY WAY, REGARDLESS OF WHETHER SUCH CLAIM IS BASED IN CONTRACT, WARRANTY, TORT, NEGLIGENCE, STRICT LIABILITY OR ANY OTHER THEORY OF LIABILITY, EVEN IF HORIZON HAS BEEN ADVISED OF THE POSSIBILITY OF SUCH DAMAGES. Further, in no event shall the liability of Horizon exceed the individual price of the Product on which liability is asserted. As Horizon has no control over use, setup, final assembly, modification or misuse, no liability shall be assumed nor accepted for any resulting damage or injury. By the act of use, setup or assembly, the user accepts all resulting liability. If you as the purchaser or user are not prepared to accept the liability associated with the use of the Product, purchaser is advised to return the Product immediately in new and unused condition to the place of purchase.

Law

These terms are governed by Illinois law (without regard to conflict of law principals). This warranty gives you specific legal rights, and you may also have other rights which vary from state to state. Horizon reserves the right to change or modify this warranty at any time without notice.

WARRANTY SERVICES

Questions, Assistance, and Services

Your local hobby store and/or place of purchase cannot provide warranty support or service. Once assembly, setup or use of the Product has been started, you must contact your local distributor or Horizon directly. This will enable Horizon to better answer your questions and service you in the event that you may need any assistance. For questions

or assistance, please visit our website at www.horizonhobby.com, submit a Product Support Inquiry, or call the toll free telephone number referenced in the Warranty and Service Contact Information section to speak with a Product Support representative.

Inspection or Services

If this Product needs to be inspected or serviced and is compliant in the country you live and use the Product in, please use the Horizon Online Service Request submission process found on our website or call Horizon to obtain a Return Merchandise Authorization (RMA) number. Pack the Product securely using a shipping carton. Please note that original boxes may be included, but are not designed to withstand the rigors of shipping without additional protection. Ship via a carrier that provides tracking and insurance for lost or damaged parcels, as Horizon is not responsible for merchandise until it arrives and is accepted at our facility. An Online Service Request is available at http://www.horizonhobby.com/content/service-center_render-service-center. If you do not have internet access, please contact Horizon Product Support to obtain a RMA number along with instructions for submitting your product for service. When calling Horizon, you will be asked to provide your complete name, street address, email address and phone number where you can be reached during business hours. When sending product into Horizon, please include your RMA number, a list of the included items, and a brief summary of the problem. A copy of your original sales receipt must be included for warranty consideration. Be sure your name, address, and RMA number are clearly written on the outside of the shipping carton.

NOTICE: Do not ship Li-Po batteries to Horizon. If you have any issue with a Li-Po battery, please contact the appropriate Horizon Product Support office.

Warranty Requirements

For Warranty consideration, you must include your original sales receipt verifying the proof-of-purchase date. Provided warranty conditions have been met, your Product will be serviced or replaced free of charge. Service or replacement decisions are at the sole discretion of Horizon.

Non-Warranty Service

Should your service not be covered by warranty, service will be completed and payment will be required without notification or estimate of the expense unless the expense exceeds 50% of the retail purchase cost. By submitting the item for service you are agreeing to payment of the service without notification. Service estimates are available upon request. You must include this request with your item submitted for service. Non-warranty service estimates will be billed a minimum of 1/2 hour of labor. In addition you will be billed for return freight. Horizon accepts money orders and cashier's checks, as well as Visa, MasterCard, American Express, and Discover cards. By submitting any item to Horizon for service, you are agreeing to Horizon's Terms and Conditions found on our website http://www.horizonhobby.com/content/service-center_render-service-center.

ATTENTION: Horizon service is limited to Product compliant in the country of use and ownership. If received, a non-compliant Product will not be serviced. Further, the sender will be responsible for arranging return shipment of the un-serviced Product, through a carrier of the sender's choice and at the sender's expense. Horizon will hold non-compliant Product for a period of 60 days from notification, after which it will be discarded.

10/15

WARRANTY AND SERVICE CONTACT INFORMATION

COUNTRY OF PURCHASE	HORIZON HOBBY	CONTACT INFORMATION	ADDRESS
United States of America	Horizon Service Center (Repairs and Repair Requests)	servicecenter.horizonhobby.com/RequestForm/	2904 Research Rd Champaign, IL 61822
	Horizon Product Support (Product Technical Assistance)	productsupport@horizonhobby.com 877-504-0233	
	Sales	websales@horizonhobby.com 800-338-4639	
European Union	Horizon Technischer Service Sales: Horizon Hobby GmbH	service@horizonhobby.eu +49 (0) 4121 2655 100	Hanskampring 9 D 22885 Barsbüttel, Germany

FCC INFORMATION

FCC ID: BRWSPMSLT200F

SUPPLIER'S DECLARATION OF CONFORMITY

Axial Capra UTB18. SLT2 4WD RTR (AXI01002)

FC This device complies with part 15 of the FCC Rules. Operation is subject to the following two conditions: (1) This device may not cause harmful interference, and (2) this device must accept any interference received, including interference that may cause undesired operation.

CAUTION: changes or modifications not expressly approved by the party responsible for compliance could void the user's authority to operate the equipment.

NOTE: This equipment has been tested and found to comply with the limits for a Class B digital device, pursuant to part 15 of the FCC Rules. These limits are designed to provide reasonable protection against harmful interference in a residential installation. This equipment generates, uses and can radiate radio frequency energy and, if not installed and used in accordance with the instructions, may cause harmful interference to radio communications. However, there is no guarantee that interference will not occur in a particular installation. If

this equipment does cause harmful interference to radio or television reception, which can be determined by turning the equipment off and on, the user is encouraged to try to correct the interference by one or more of the following measures:

- Reorient or relocate the receiving antenna.
- Increase the separation between the equipment and receiver.
- Connect the equipment into an outlet on a circuit different from that to which the receiver is connected.
- Consult the dealer or an experienced radio/TV technician for help.

Horizon Hobby, LLC
2904 Research Rd.,
Champaign, IL 61822
Email: compliance@horizonhobby.com
Web: HorizonHobby.com

IC INFORMATION

CAN ICES-3 (B)/NMB-3(B)

IC: 6157A-SPMSLT200F

This device contains license-exempt transmitter(s)/receivers(s) that comply with Innovation, Science, and Economic Development Canada's license-exempt RSS(s). Operation is subject to the following 2 conditions:

1. This device may not cause interference.

2. This device must accept any interference, including interference that may cause undesired operation of the device.

COMPLIANCE INFORMATION FOR THE EUROPEAN UNION



EU COMPLIANCE STATEMENT:

Axial Capra UTB18. SLT2 4WD RTR (AXI01002)

Hereby, Horizon Hobby, LLC declares that the device is in compliance with the following: Low Voltage Directive (LVD) 2014/35/EU, 2014/30/EU EMC Directive, EU Radio Equipment Directive 2014/53/EU; RoHS 2 Directive 2011/65/EU; RoHS 3 Directive - Amending 2011/65/EU Annex II 2015/863.

The full text of the EU declaration of conformity is available at the following internet address: <https://www.horizonhobby.com/content/support-render-compliance>.

Wireless Frequency Range and Wireless Output Power

Transmitter

2410MHz—2480MHz
23.23dB

EU Manufacturer of Record:

Horizon Hobby, LLC
2904 Research Road
Champaign, IL 61822 USA

EU Importer of Record:

Horizon Hobby, GmbH
Hanskampring 9
22885 Barsbüttel Germany

WEEE NOTICE:



This appliance is labeled in accordance with European Directive 2012/19/EU concerning waste of electrical and electronic equipment (WEEE). This label indicates that this product should not be disposed of with household waste. It should be deposited at an appropriate facility to enable recovery and recycling.



E328

EXPLODED VIEWS // EXPLOSIONSZEICHNUNGEN // VUES ÉCLATÉES // VISTE ESPLOSE

**CHASSIS
KAROSSERIE
CHÂSSIS
TELAIO**

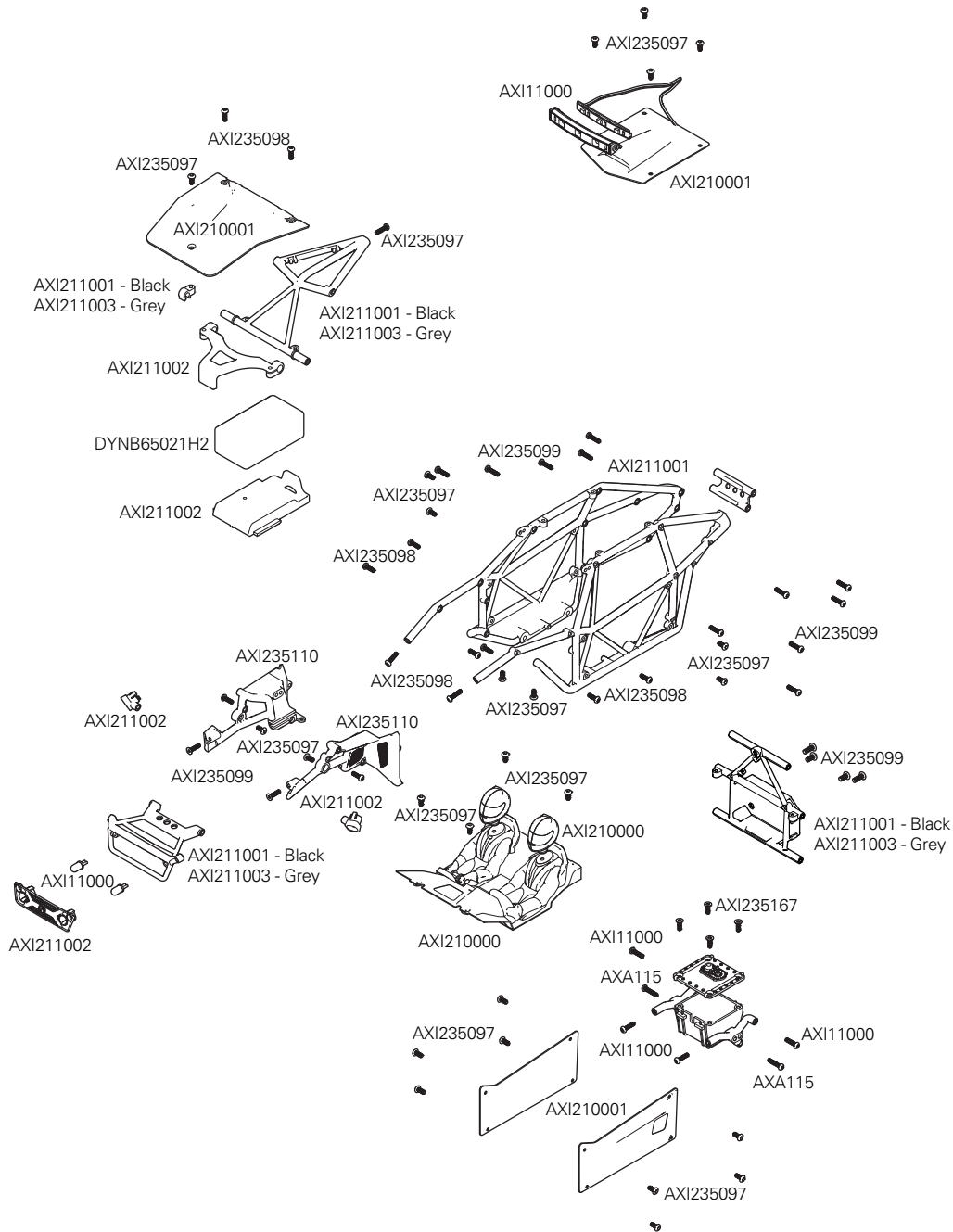

EXPLODED VIEWS // EXPLOSIONSZEICHNUNGEN // VUES ÉCLATÉES // VISTE ESPLOSE

**FRONT AXLE
VORDERACHSE
ESSIEU AVANT
ASSALE ANTERIORE**

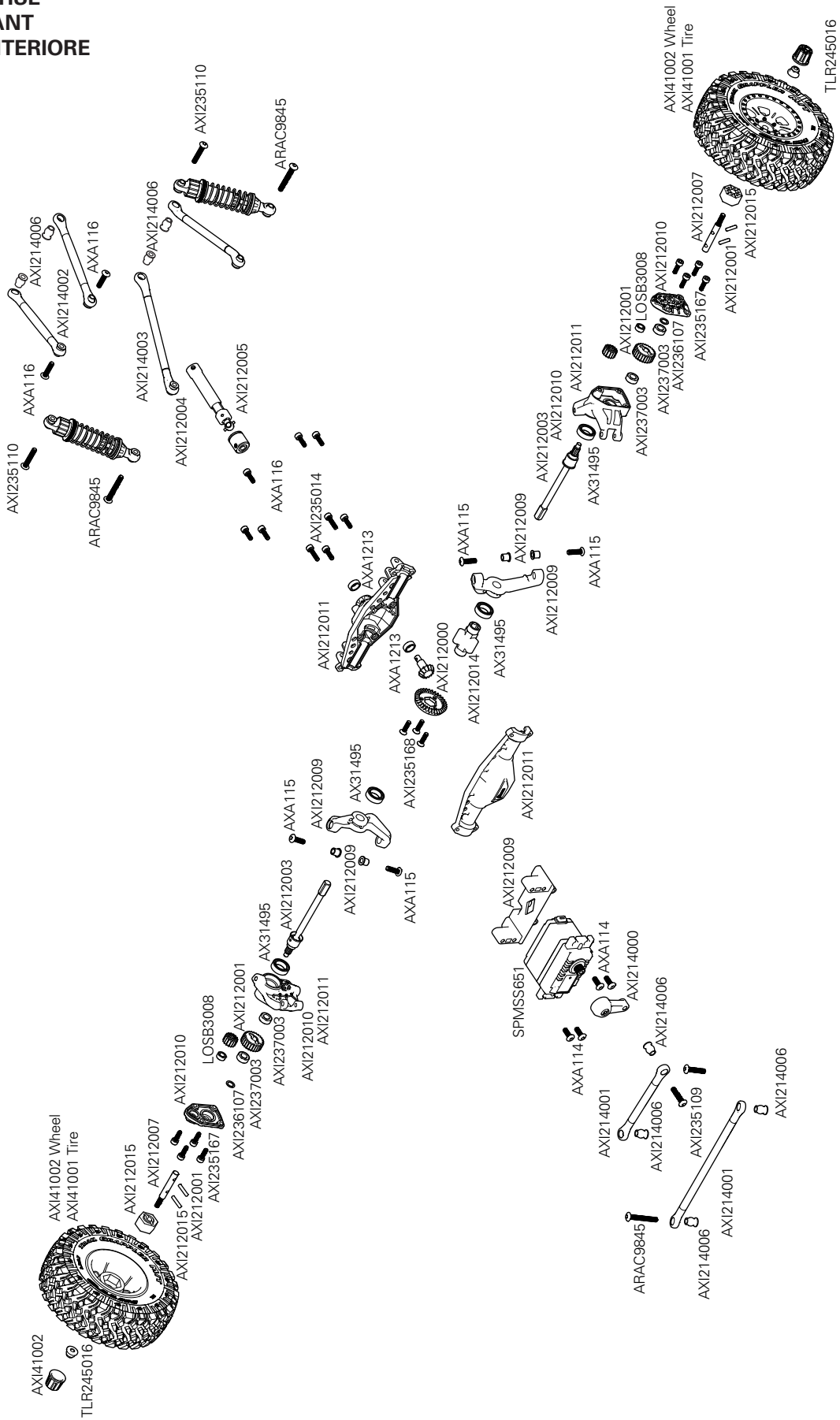

EXPLODED VIEWS // EXPLOSIONSZEICHNUNGEN // VUES ÉCLATÉES // VISTE ESPLOSE

**TRANSMISSION
GETRIEBE
TRANSMISSION
TRASMISSIONE**

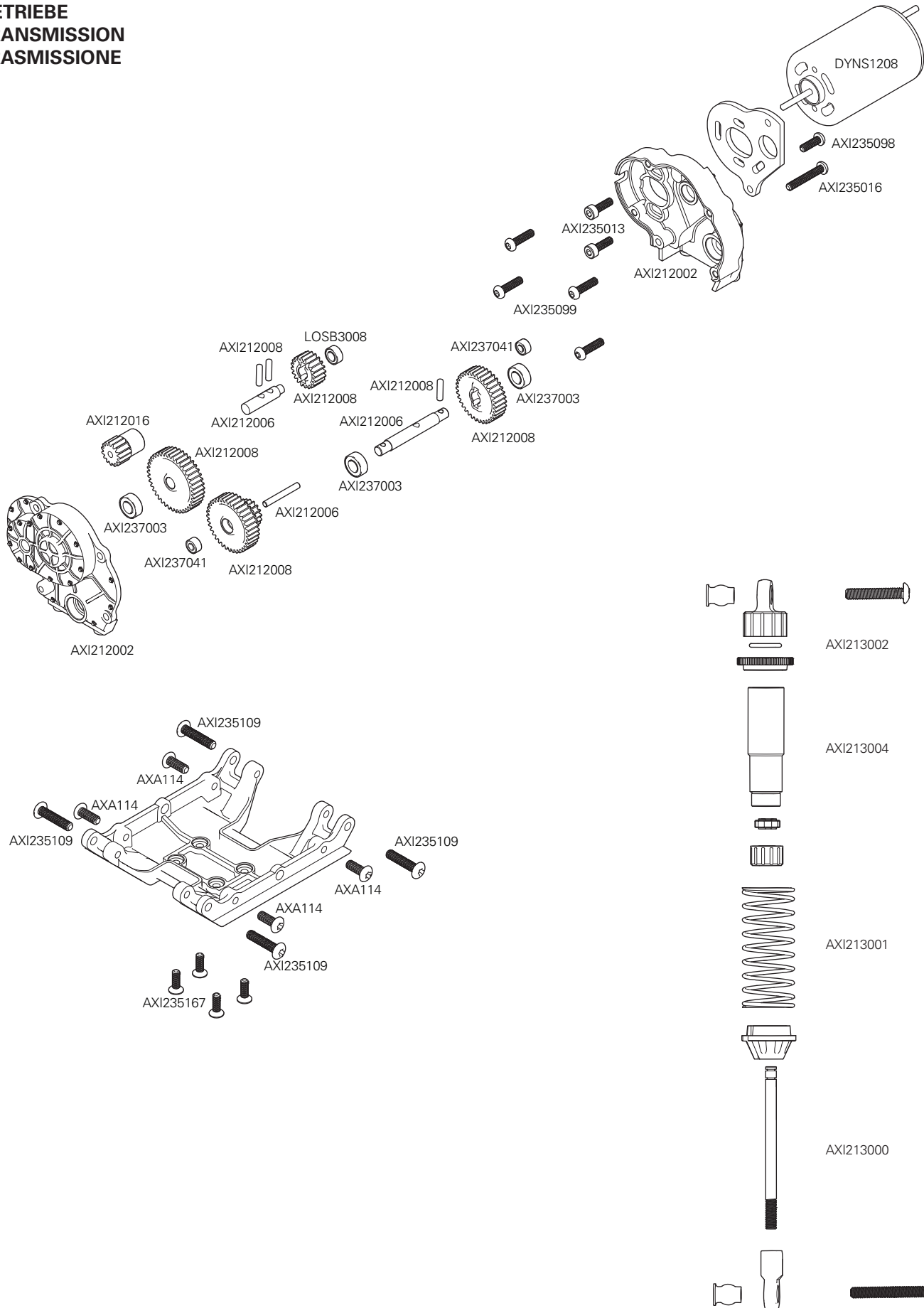

PARTS LISTS // TEILELISTEN // LISTE DES PIÈCES // ELENCO COMPONENTI

Part #	Description	Beschreibung	Description	Descrizione
ARAC9845	AR721322 Btn Hd Scr 3x22mm(10)	AR721322 Rundkopfschraube 3 x 22 mm (10)	AR721322 Vis à tête bombée 3 x 22 mm (10)	AR721322 Vit tst tnda 3x22mm(10)
AXI11000	LED Lights(4) /Light Bar: UTB18	LED-Leuchten (4)/Leuchtbalken: UTB18	(4) éclairages/barre d'éclairage à DEL : UTB18	Luci LED(4)/Barra luminosa: UTB18
AXI210000	Interior Set,Clr, Capra: UTB18	Interieurset, transparent, Capra: UTB18	Ensemble intérieur, transparent, Capra : UTB18	Set interni, trasp, Capra: UTB18
AXI210001	Body Panel Set,Clr, Capra:UTB18	Karosserieteilesatz, transparent, Capra: UTB18	Ensemble panneau de carrosserie, transparent, Capra : UTB18	Set pann crrz, trasp, Capra:UTB18
AXI211001	Cage Set,Complete,(Black):UTB18	Überrollkäfigset, komplett, (Schwarz): UTB18	Ensemble cage, complet, (noir) : UTB18	Set scocca completa (nero):UTB18
AXI211002	Capra Cage Cpnts (Black):UTB18	Capra Komponenten Überrollkäfig (Schwarz): UTB18	Composants de cage Capra (noirs) : UTB18	Comp scocca Capra (nero):UTB18
AXI211003	Cage Set, Complete, Grey: UTB18	Überrollkäfigset, komplett, Grau: UTB18	Ensemble cage, complet, gris : UTB18	Set scocca cmplta, grigio: UTB18
AXI212000	48P BevelGearSet 33T/13T:UTB18	48P Kegelaradgetriebesatz 33T/13T: UTB18	Ensemble engrenage conique 48P 33T/13T : UTB18	Set ingr conici 48P 33T/13T:UTB18
AXI212000	48P BevelGearSet 33T/13T:UTB18	48P Kegelaradgetriebesatz 33T/13T: UTB18	Ensemble engrenage conique 48P 33T/13T : UTB18	Set ingr conici 48P 33T/13T:UTB18
AXI212001	48P PrtlGearSt 26T/15T(2):UTB18	48P Portalachssatz 26T/15T(2):UTB18	Ensemble engrenage portique 48P 26T/15T (2) : UTB18	Set ingr Prt 48P 26T/15T(2):UTB18
AXI212002	Transmission Housing Set: UTB18	Getriebegehäusesatz: UTB18	Ensemble boîte de transmission : UTB18	Kit allgiamnto trasmissione: UTB18
AXI212003	Universal Axle Set (2): UTB18	Universalachsensatz (2): UTB18	Ensemble essieu universel (2) : UTB18	Set assale universale (2): UTB18
AXI212004	WB8-18 DrveshftCouplr St:UTB18	WB8-18 Antriebswellenkupplungssatz: UTB18	Ensemble coupleur d'arbre moteur WB8-18 : UTB18	WB8-18 set accp alb trsm:UTB18
AXI212005	WB8-18 Driveshaft Set: UTB18	WB8-18 Antriebswellensatz: UTB18	Ensemble arbre moteur WB8-18 : UTB18	WB11 set accp alb trsm: UTB18
AXI212006	Transmissn Shaft Set(3): UTB18	Getriebewellensatz (3): UTB18	Ensemble arbre de transmission (3) : UTB18	Set alberi trasmissione (3): UTB18
AXI212007	Portal Stub Axle (2): UTB18	Portalachsschenkel (2): UTB18	Demi-essieu de portique (2) : UTB18	Fusello Portal (2): UTB18
AXI212008	48P Transmission GearSet: UTB18	48P Übertragungsgetriebesatz: UTB18	Ensemble engrenage de transmission 48P : UTB18	Set ingr trasmissione 48P: UTB18
AXI212009	PortalAxleComponents,Frnt:UTB18	Portalachskomponenten, Front: UTB18	Composants d'essieu de portique, avant : UTB18	Cmpnenti assali Portal, ant:UTB18
AXI212010	Portal Strng Knkle Set: UTB18	Portallenkrollensatz: UTB18	Ensemble rotule de direction de portique : UTB18	Set fuso a snodo Portal: UTB18
AXI212011	Currie F9 Prtal Axle Hsng:UTB18	Currie F9-Portalachsgehäuse: UTB18	Carter d'essieu de portique Currie F9 : UTB18	Currie F9 Portal allgm ass:UTB18
AXI212012	PortalAxleComponents,Rear:UTB18	Portalachskomponenten, Heck: UTB18	Composants d'essieu de portique, arrière : UTB18	Comp assali Portal, post:UTB18
AXI212013	Straight Axle Shaft (2): UTB18	Gerade Achswelle (2): UTB18	Arbre d'essieu droit (2) : UTB18	Set assale dritto (2): UTB18
AXI212014	Axle Differential Spool: UTB18	Achsdifferentialspule: UTB18	Spool de différentiel d'essieu : UTB18	Cursore diff assale: UTB18
AXI212015	12mm Hex Hub Set (4): UTB18	12 mm Hexnabensatz (4): UTB18	Ensemble moyeu hexagonal 12 mm (4) : UTB18	Set mozzo hex 12 mm (4): UTB18
AXI212016	Pinion Gr 48P 13T -Stl 2.3 Shaf	Zahnradgetriebe 48P 13T – Stahl 2,3 Welle	Pignon 48P 13T - arbre 2,3 acier	Pignone 48P 13T acciaio alb 2.3
AXI213000	Shock Shaft M3x45mm (2): UTB18	Kolbenstange M3 x 45 mm (2): UTB18	Bras d'amortisseur M3 x 45 mm (2) : UTB18	Albero amm M3x45 mm (2): UTB18
AXI213001	Sprng 13x54mm1.7lbs/in(2):UTB18	Feder 13 x 54 mm 1,7lbs/in (2): UTB18	Ressort 13 x 54 mm 0,2 Nm (1,7 lb/po) (2) : UTB18	Molla 13x54mm1,7lb/in(2):UTB18
AXI213002	Shock O-Ring Set (4): UTB18	O-Ring-Satz für den Stoßdämpfer (4): UTB18	Ensemble joint torique d'amortisseur (4) : UTB18	Set O-Ring amm (4): UTB18
AXI213003	Shock Parts (4): UTB18	Stoßdämpferteile (4): UTB18	Pièces d'amortisseur (4) : UTB18	Ricambi amm (4): UTB18
AXI213004	Shock Body 10x33mm (2): UTB18	Stoßdämpfergehäuse 10 x 33 mm (2): UTB18	Corps d'amortisseur 10 x 33 mm (2) : UTB18	Corpo amm 10x33mm (2): UTB18
AXI214000	Servo Horn Set 23/25T: UTB18	Servohornsatz 23/25T: UTB18	Ensemble renvoi de commande de servo 23/25T : UTB18	Set squad servo 23/25T: UTB18
AXI214001	Steering Link Set: UTB18	Lenkgliedersatz: UTB18	Ensemble timonerie de direction : UTB18	Set braccetti sterzo: UTB18
AXI214002	Upper Link Set, F/R: UTB18	Oberes Verbindungsglied, F/H: UTB18	Ensemble timonerie supérieure, avant/arrière : UTB18	Set brac sup, ant/post: UTB18
AXI214003	Stainless Lnks M3x68.5(2):UTB18	Edelstahlstangen M3 x 68,5 (2): UTB18	Timonerie en acier inoxydable M3 x 68,5 (2) : UTB18	Tiranti acc inox M3x68.5(2):UTB18
AXI214004	Stainless Lnks M3x83 (2): UTB18	Edelstahlstangen M3 x 83 (2): UTB18	Timonerie en acier inoxydable M3 x 83 (2) : UTB18	Trnt acc inox M3x83(2): UTB18
AXI214006	Rod Ends M3 (20): UTB18	Stangenkopf M3 (20): UTB18	Embouts de bielle M3 (20) : UTB18	Teste snodo M3 (20): UTB18
AXI221000	Chassis Skid Plate: UTB18	Gleitplatte Fahrwerk: UTB18	Plaque de protection pour châssis : UTB18	Prot. sottoscocca telaio: UTB18
AXI235013	M2.5x8 Cap Head Screw (10)	M2,5 x 8 Inbusschraube (10)	Vis d'assemblage creuse M2,5 x 8 (10)	Vite testa cilindrica M2.5x8 (10)
AXI235013	M2.5x8 Cap Head Screw (10)	M2,5 x 8 Inbusschraube (10)	Vis d'assemblage creuse M2,5 x 8 (10)	Vite testa cilindrica M2.5x8 (10)
AXI235014	M2.5 x 10mm, Cap Head Screw (10)	M2,5 x 10 mm, Inbusschraube (10)	Vis d'assemblage creuse, M2,5 x 10 mm (10)	Viti testa cilindrica M2.5x10 (10)
AXI235167	M2.5 x 8mm Flat Head Screw (10)	M2,5 x 8 mm Flachkopfschraube (10)	Vis à tête plate M2,5 x 8 mm (10)	Viti testa piatta M2.5 x 8 mm (10)
AXI235168	M2.5 x 10mm Flat Head Screw (10)	M2,5 x 10mm Flachkopfschraube (10)	Vis à tête plate M2,5 x 10mm (10)	Viti testa piatta M2.5 x 10mm (10)
AXI236107	4x6x0.3mm Washer (10)	4 x 6 x 0,3 mm Unterlegscheibe (10)	Rondelle 4 x 6 x 0,3 mm (10)	Rondelle 4x6x0,3 mm (10)
AXI237003	4mm x 8mm x 3mm Ball Bearing (2)	4 mm x 8 mm x 3 mm Kugellager (2)	Roulement à billes 4 x 8 x 3 mm (2)	Cuscinetti sfera 4x8x12 mm (2)

Part #	Description	Beschreibung	Description	Descrizione
AXI237041	2x5x2.5mm Ball Bearing (2)	2 x 5 x 2,5 mm Kugellager (2)	Roulement à billes 2 x 5 x 2,5 mm (2)	Cuscinetti sfera 2x5x2,5 mm (2)
AXI41001	3.6" Nitto Trail Grappler M/T(2)	3,6" Nitto Trail Grappler M/T(2)	3,6 Nitto Trail Grappler M/T (2)	3.6" Nitto Trail Grappler M/T (2)
AXI41002	1.55" Raceline Monster Wheel(2)	1,55" Raceline Monsterrad (2)	Roue Raceline Monster 1,55 (2)	Ruote 1.55" Raceline Monster (2)
AXIC0005	AXA0113 Hex Skt Butn Hd M3x6mm	AXA0113 Innensechskantschraube, Rundkopf, M3 x 6 mm	AXA0113 Douille hexagonale à tête bombée M3 x 6 mm	AXA0113 Vite cil esag inc M3x6 mm
AXIC0114	AXA114 Hex Skt Butn Hd M3x8mm	AXA114 Innensechskantschraube, Rundkopf, M3 x 8 mm	AXA114 Douille hexagonale à tête bombée M3 x 8 mm	AXA114 Vite cil esag inc M3x8 mm
AXIC0115	AXA115 Hex Skt Butn Head M3x10	AXA115 Innensechskantschraube, Rundkopf, M3x10	AXA115 Douille hexagonale à tête bombée M3 x 10	AXA115 Vite cil esag inc M3x10 mm
AXIC0116	AXA116 Hex Skt Butn Hd M3x12mm	AXA116 Innensechskantschraube, Rundkopf, M3 x 12 mm	AXA116 Douille hexagonale à tête bombée M3 x 12 mm	AXA116 Vite cil esag inc M3x12 mm
AXIC0180	AXA180 Set Screw M3x3mm Blk Ox	AXA180 Schraubensatz M3 x 3 mm, Schwarz, Oxid	AXA180 Vis de fixation M3 x 3 mm brunie	AXA180 Grano M3x3 mm nero oss
AXIC0392	AXA1392 E-clip E2 (10)	AXA1392 E-Clip E2 (10)	AXA1392 Attache en E E2 (10)	AXA1392 E-clip E2 (10)
AXIC1213	AXA1213 Bearing 5x8x2.5mm (2)	AXA1213 Lager 5 x 8 x 2,5 mm (2)	AXA1213 Roulement 5 x 8 x 2,5 mm (2)	AXA1213 Cuscinetto 5x8x2,5mm (2)
AXIC1495	AX31495 Bearing 8x12x3.55mm (2)	AX31495 Lager 8 x 12 x 3,55 mm (2)	AX31495 Roulement 8 x 12 x 3,55 mm (2)	AX31495 Cscnetto 8x12x3,55mm(2)
LOSB3008	3x6x2.5mm Ball Bearing (2)	3 x 6 x 2,5 mm Kugellager (2)	Roulement à billes 3 x 6 x 2,5 mm (2)	Cuscinetti a sfera 3x6x2,5 mm (2)
TLR245016	M3 Flanged Lock Nuts (10)	M3 Sicherungsmuttern mit Flansch (10)	Contre-écrous à collet M3 (10)	Dadi flangiati M3 (10)

ELECTRONICS // ELEKTRONIK // COMPOSANTS ÉLECTRONIQUES // ELETTRONICA

Part #	Description	Beschreibung	Description	Descrizione
DYNB65021H2	7.4V 650mAh 2S 20C LiPo, Hard	7,4 V 650 mA 2S 20C LiPo, hart	LiPo 7,4 V 650 mAh 2S 20C, à boîtier rigide	7,4 V 650 mAh 2S 20C LiPo, Hard
SPMRSLT200F	SLT2 2 Channel 2.4GHz Transmitter	SLT2 3-Kanal 2,4 GHz Sender	Émetteur SLT2 3 canaux 2,4 GHz	Trasmittente SLT2 3 Canali 2,4 GHz
SPMSS651	Servo	Servo	Servo	Servo
SPMXSE2525RX	2 in 1 ESC and receiver	2-in-1 Geschwindigkeitsregler und-Empfänger	Récepteur et variateur ESC 2-en-1	ESC e ricevitore 2-in-1
DYNS1208	Tazer 37-Turn 380 Brushed Motor	Tazer 380-Bürstenmotor mit 37 Turns	Moteur à balais Tazer 37-Turn 380	Motore a spazzole Tazer 37 T 380
DYNC1063	USB Charger Lipo	USB-LiPo-Ladegerät	Chargeur USB Lipo	Caricabatterie USB LiPo

RECOMMENDED PARTS // EMPFOHLENE TEILE // PIÈCES RECOMMANDÉES // PARTI CONSIGLIATE

Part #	Description	Beschreibung	Description	Descrizione
DYNB825H2	7.4V 800mAh 2S50C Hardcase LiPo Batt:EC	7,4V 800mAh 2S50C LiPo-Hartschalen-Akku: EC	LiPo 7,4 V 650 mAh 2S 20C, à boîtier rigide	7,4V 800mAh 2S50C Hardcase LiPo Batt:EC

OPTIONAL PARTS // OPTIONALE TEILE // PIÈCES FACULTATIVES // PARTI OPZIONALI

Part #	Description	Beschreibung	Description	Descrizione
AXI312004	Portal Box Cover, Brass(2):UTB18	Portalboxabdeckung, Messing (2): UTB18	Couvercle de boîte de portique, laiton (2) : UTB18	Cprch box Portal, ottone (2):UTB18
AXI312005	Hex Hubs, Brass (7g) (4): UTB18	Hexnaben, Messing (7 g) (4): UTB18	Moyeux hexagonaux, laiton (7 g) (4) : UTB18	Mozzi hex, ottone (7 g) (4): UTB18
AXI312006	48P Prt Gear OvrDrv 25T/16T(2)	48P Getriebeanschluss Übersteuerung 25T/16T(2)	Surmultiplicateur d'engrenage de portique 48P 25T/16T (2)	OvrDrv ingr 48P Prt 25T/16T (2)
AXI314001	Front Link Set, Alum: UTB18	Verbindungssatz Front, Alum: UTB18	Ensemble timonerie avant, aluminium : UTB18	Set braccetti anteriori, alu: UTB18
AXI314002	Steering Links Set, Alum: UTB18	Lenkgliedersatz, Alum: UTB18	Ensemble timonerie de direction, aluminium : UTB18	Set tiranti sterzo, alu: UTB18
AXI314003	Rear Links Set, Alum: UTB18	Hinterer Verbindungsgliedersatz, Alum: UTB18	Ensemble timonerie arrière, aluminium : UTB18	Set braccetti psteriori, alu: UTB18
AXI314004	Upper Rr Link Riser, Alum: UTB18	Oberer hinterer Verbindungsgliedspoiler, Alum: UTB18	Support de timonerie arrière supérieure, aluminium : UTB18	Rialzo brccct sup post, alu: UTB18
SPMSLT300	SLT3 3CH 2.4Ghz with SR315 RX	SLT3 3CH 2,4 Ghz mit SR315 RX	Récepteur STL3 3 canaux 2,4 GHz avec SR315	SLT3 3 CH 2,4Ghz con RX SR315
SPMXC1080	Smart S1100 AC Charger, 1x100W	Smart S1100 Wechselstrom-Ladegerät, 1x100 W	Chargeur c.a. Smart S1100, 1 x 100 W	Caricabatterie Smart S1100 CA, 1x100 W
SPMXC1000	Smart S1200 DC Charger, 1x200W	Smart S1200 Gleichstrom-Ladegerät, 1x200 W	Chargeur c.c. S1200 Smart, 1 x 200 W	Caricabatterie Smart S1200 CC, 1x200 W
SPMXC1010	Smart S2100 AC Charger, 2x100W	Smart S2100 Wechselstrom-Ladegerät, 2x100 W	Chargeur c.a. Smart S2100, 2 x 100 W	Caricabatterie Smart S2100 AC 2x100 W
SPMXC1020	Smart S120 USB-C Charger, 1x20	Smart S120 USB-C-Ladegerät, 1 x 20 W	Chargeur Smart S120 USB-C, 1 x 20	Caricabatterie Smart S120 USB-C, 1x20 W
SPMXC1050	Smart S1500 DC Charger, 1x500W	Smart S1500 Gleichstrom-Ladegerät, 1x500 W	Chargeur Smart c.c. S1500, 1 x 500 W	Caricabatterie Smart S1500 CC, 1x500 W
SPMXC1070	Smart S150 AC/DC Charger, 1x50W	Smart S150 Wechsel-/Gleichstrom-Ladegerät, 1x50 W	Chargeur Smart c.a./c.c. S150, 1 x 50 W	Caricabatterie Smart S150 AC/DC 1x50 W
SPMXC2010	Smart S2200 G2 AC Charger, 2x200W	Smart S2200 G2 Wechselstrom-Ladegerät, 2x200 W	Chargeur Smart CA S2200 G2, 2 x 200 W	Caricabatterie Smart S2200 G2 CA, 2x200 W
SPMXC2020	Smart S1200 G2 AC Charger; 1x200	Smart S1200 G2 Wechselstrom-Ladegerät; 1x200 W	Chargeur Smart CA S1200 G2, 1 x 200 W	Caricabatterie Smart S1200 CA G2, 1x200 W
SPMXC2040	Smart S1400 G2 AC Charger, 1x400	Smart S1400 G2 Wechselstrom-Ladegerät, 1x400	Chargeur c.a. Smart S1400 G2, 1 x 400	Caricabatterie SmartS1400 G2 AC1x400



BUILD ADVENTURE.

facebook.com/axialinc | instagram.com/axialracing | twitter.com/axialrc
youtube.com/axialvideos | flickr.com/axialrc



WWW.AXIALADVENTURE.COM

©2022 Horizon Hobby, LLC.

Axial, the Axial logo, SCX-10, SLT2, IC3, EC3, Passport, and the Horizon Hobby logo are trademarks or registered trademarks of Horizon Hobby, LLC.

The Spektrum trademark is used with permission of Bachmann Industries, Inc. All other trademarks, service marks and logos are property of their respective owners.

US 9,930,567. US 10,419,970. US 10,849,013. Other patents pending.

Created 6/22

AXI01002

344721