

BLADE.

INDUCTRIX[®] BL **FPV**

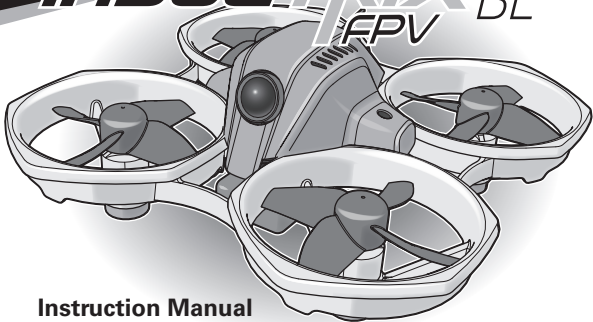

Instruction Manual
Bedienungsanleitung
Manuel d'utilisation
Manuale di Istruzioni

BNF
BASIC

NOTICE

All instructions, warranties and other collateral documents are subject to change at the sole discretion of Horizon Hobby, LLC. For up-to-date product literature, visit www.horizonhobby.com and click on the support tab for this product.

Meaning of Special Language

The following terms are used throughout the product literature to indicate various levels of potential harm when operating this product:

WARNING: Procedures, which if not properly followed, create the probability of property damage, collateral damage, and serious injury OR create a high probability of superficial injury.

CAUTION: Procedures, which if not properly followed, create the probability of physical property damage AND a possibility of serious injury.

NOTICE: Procedures, which if not properly followed, create a possibility of physical property damage AND a little or no possibility of injury.



WARNING: Read the ENTIRE instruction manual to become familiar with the features of the product before operating.

Failure to operate the product correctly can result in damage to the product, personal property and cause serious injury.

This is a sophisticated hobby product. It must be operated with caution and common sense and requires some basic mechanical

ability. Failure to operate this Product in a safe and responsible manner could result in injury or damage to the product or other property. This product is not intended for use by children without direct adult supervision. Do not use with incompatible components or alter this product in any way outside of the instructions provided by Horizon Hobby, LLC. This manual contains instructions for safety, operation and maintenance. It is essential to read and follow all the instructions and warnings in the manual, prior to assembly, setup or use, in order to operate correctly and avoid damage or serious injury.

Age Recommendation: Not for children under 14 years.

This is not a toy.

Safety Precautions and Warnings

- Always keep a safe distance in all directions around your model to avoid collisions or injury. This model is controlled by a radio signal subject to interference from many sources outside your control. Interference can cause momentary loss of control.
- Always operate your model in open spaces away from full-size vehicles, traffic and people.
- Always carefully follow the directions and warnings for this and any optional support equipment (chargers, rechargeable battery packs, etc.).
- Always keep all chemicals, small parts and anything electrical out of the reach of children.

- Always avoid water exposure to all equipment not specifically designed and protected for this purpose. Moisture causes damage to electronics.
- Never place any portion of the model in your mouth as it could cause serious injury or even death.
- Never operate your model with low transmitter batteries.
- Always keep aircraft in sight and under control.
- Always move the throttle fully down at rotor strike.
- Always use fully charged batteries.
- Always keep transmitter powered on while aircraft is powered.
- Always remove batteries before disassembly.
- Always keep moving parts clean.
- Always keep parts dry.
- Always let parts cool after use before touching.
- Always remove batteries after use.
- Never operate aircraft with damaged wiring.
- Never touch moving parts.

NOTICE: Consult local laws and ordinances before operating FPV (first person view) equipment. In some areas, FPV operation may be limited or prohibited. You are responsible for operating this product in a legal and responsible manner.

If you are operating this product in North America, you are required to have an Amateur Radio (HAM) license. Visit www.arrl.org for more information.

Table of Contents

Specifications	6	Changing the	
First Flight Preparation	7	Center LED Taillight Color	18
Flying Checklist.....	7	Video System (BNF with FPV) ...	18
Charging Warnings.....	8	Troubleshooting Guide	21
Installing the Propellers	9	Exploded View.....	24
Install the Flight Battery	10	Parts Listings.....	25
BNF Transmitter Setup.....	11	Optional Parts.....	25
Transmitter		Limited Warranty.....	26
and Receiver Binding	11	Warranty and Service	
Understanding the		Contact Information.....	31
Primary Flight Controls	12	FCC Information.....	32
Flight Mode Selection.....	14	IC Information	33
Fly the Quadcopter	15	Compliance Information	
Low Voltage Cutoff (LVC).....	17	for the European Union.....	34
Battery Level Indicator	17		

Specifications

Length	4.33 in (110mm)
Width	4.13 in (105mm)
Height	1.97 in (50mm)
Propeller Diameter	1.57 in (40mm)
Flying Weight	1.94 oz (55g)

*To receive product updates, special offers and more,
register your product at www.bladehelis.com.*

Box Contents:

- Inductrix[®] BL FPV Quadcopter

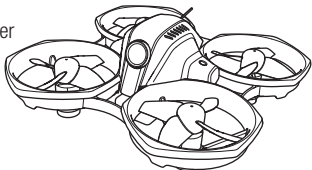

First Flight Preparation

- Remove and inspect contents
- Begin charging the flight battery
- Assemble the aircraft
- Program your computer transmitter
- Install the flight battery in the aircraft (once it has been fully charged)
- Bind your transmitter
- Familiarize yourself with the controls
- Find a suitable area for flying

Flying Checklist

- Always turn the transmitter on first**
- Plug the flight battery into the lead from the ESC
- Allow the ESC to initialize and arm properly
- Fly the model
- Land the model
- Unplug the flight battery from the ESC
- Always turn the transmitter off last**

Charging Warnings



WARNING: Failure to comply with the following warnings could result in product malfunction, electrical issues, excessive heat, FIRE, and ultimately injury and property damage.

- **NEVER LEAVE CHARGING BATTERIES UNATTENDED.**
- **NEVER CHARGE BATTERIES OVERNIGHT.**
- Never charge damaged batteries. If the battery begins to swell during charging or use, discontinue immediately.
- Always use the included battery and charger. Disconnect the battery after charging.
- Charge batteries away from flammable materials in a well-ventilated area.
- Never charge, transport, or store batteries in hot, cold, or very sunny places (recommended between 40–120° F or 5–49° C).

Charge the Flight Battery



CAUTION: Only use chargers specifically designed to charge the included Li-Po battery. Failure to do so could result in fire, causing injury or property damage.



CAUTION: Never exceed the recommended charge rate.

Installing the Propellers

1. Refer to the illustration for the proper motor rotation and propeller location.

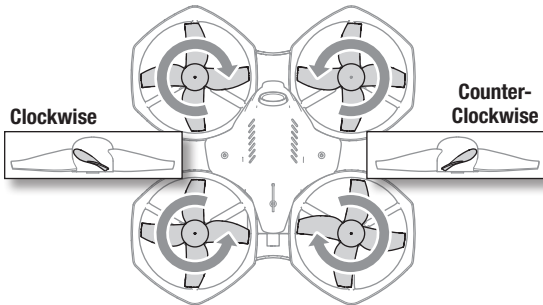

2. The propellers are press fit onto the motor shafts. Remove the propellers by pulling the center hub straight up away from the motor.
3. Install the propellers by pressing the center hub over the motor shaft, being careful not to press it too far down on the shaft. The propeller and motor should spin freely when installed correctly.

Install the Flight Battery

1 Throttle down



2 Power ON

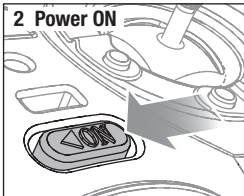

3

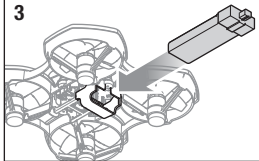

4

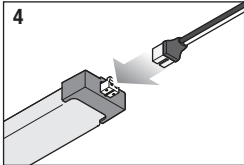

CAUTION: Always disconnect the Li-Po battery from the aircraft when not flying to avoid over-discharging the battery. Batteries discharged to a voltage lower than the lowest approved voltage may become damaged, resulting in loss of performance and potential fire when the batteries are charged.

BNF Transmitter Setup

If you are using a computer transmitter, set the model type to “Acro” or “Airplane” mode. In the channel input menu, set channel 6 (Aux1) to a momentary switch such as the bind button (I) and channel 5 (Gear) to a 3-position switch (switch B). In the Servo Setup menu, reverse channel 6 (Aux1). Bind the quadcopter to your transmitter following the Transmitter and Receiver Binding directions below.

Transmitter and Receiver Binding

General Binding Procedure (BNF®)

1. Disconnect the flight battery from the quadcopter.
2. Set the model type in your transmitter settings to “Acro” mode.
3. Center all trims on your transmitter.
4. Power off the transmitter and fully lower the throttle.
5. Connect the flight battery in the quadcopter. Aircraft LED's will begin flashing slowly, turn aircraft upside down until LED flash rapidly indicating the Inductrix is in bind mode.
6. Put the transmitter into bind mode while powering on the transmitter.
7. Release the bind button/switch after 2–3 seconds. The quadcopter is bound when all of the LEDs on the aircraft turn solid.
8. Disconnect the flight battery and power the transmitter off.

Understanding the Primary Flight Controls

If you are not familiar with the controls of your quadcopter, take a few minutes to familiarize yourself with them before attempting your first flight.

Throttle

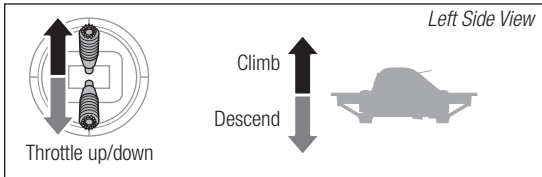

Rudder

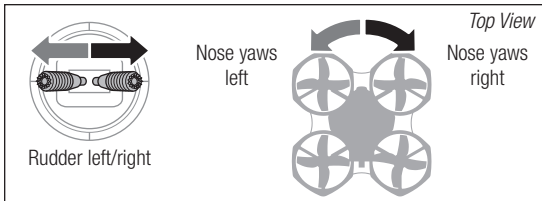

Elevator

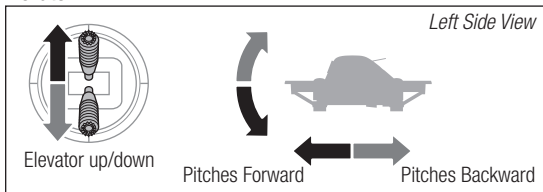

Aileron

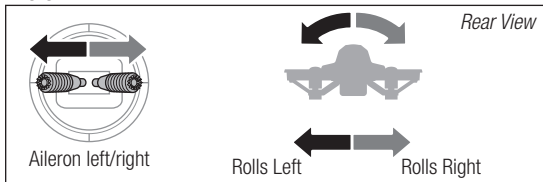

Flight Mode Selection

Cycle between the flight modes by changing the position of the flight mode switch as programmed in the binding section above. The active flight mode is indicated by the LED taillight on the quadcopter*.

- **Safe mode (blue LED, switch position 0):** The bank angle is limited. When the sticks are released, the quadcopter will return to level flight.
- **Horizon Mode (magenta LED, switch position 1):** Keeps the aircraft level when there are no inputs, but allows flips and rolls when the stick is at full deflection.
- **AS3X mode (red LED, switch position 2):** The quadcopter has no bank angle limits and will not return to level flight if the sticks are released. Use rates and expo to tune the performance according to your flying style.

* The LED taillight only indicates the active flight mode continuously if the color mode of the LED has not been changed. See *Changing the LED Taillight Color* for more information.

Fly the Quadcopter

The LEDs indicate the front and back of the quadcopter. The white LEDs indicate the front. The red LEDs and tail light indicate the back.

Takeoff

Arm the motors by pressing the arming switch. Increase the throttle until the model is approximately 2 ft. (600mm) off the ground in a low-level hover and concentrate on balancing the throttle stick's position so that the quadcopter holds a steady hover altitude. In some cases, you may need to make a few short "hops" to an altitude of just a few inches until you become familiar with the control inputs and trim settings required to maintain a steady hover and altitude.

Hovering

The Inductrix[®] quadcopter requires minor throttle adjustments to maintain its altitude in hover. Remember to keep these throttle adjustments as minimal as possible. Large adjustments could result in a loss of control or a possible crash.

While attempting to establish a low-level hover, check to see if any trim adjustments are required to keep the quadcopter from drifting in various directions. If you find that it constantly drifts without any directional control input, land the model before making any adjustments to the trim settings.

- If the nose of the quadcopter rotates to the left or right, adjust the rudder trim in the opposite direction.

- If the quadcopter continually drifts forward or backward, adjust the elevator trim in the opposite direction.
- If the quadcopter continually drifts to the left or right, adjust the aileron trim in the opposite direction.

Continue making minor trim adjustments until the machine hovers at a low altitude with very little drifting and directional control input. If this is your first multicopter or helicopter, seek the help of an experienced pilot to trim the model for you before making your first flight.

With your quadcopter properly trimmed and maintaining a stable low-level hover, practice using the rudder, elevator and aileron controls to familiarize yourself with the machine's responses to control inputs. Remember to keep the control inputs as minimal as possible.

Average flight times are 3-4 minutes.

Landing

To land the quadcopter, establish a low level hover. Slowly lower the throttle until the quadcopter touches down.

After landing, press the arming button to disarm the motors.

Unplug and remove the flight battery.

To prevent excessive wear to the motors, always allow the motors to cool between flights.

NOTICE: Crash damage is not covered under warranty.

Low Voltage Cutoff (LVC)

Once the battery reaches 3V under load, the ESC will continuously lower power supplied to the motor until complete shutdown occurs. This helps prevent over-discharge of the Li-Po battery. Land immediately once the ESC activates LVC. Continuing to fly after LVC can damage the battery, cause a crash or both. Crash damage and batteries damaged due to over-discharge are not covered under warranty.

Repeatedly flying the aircraft until LVC activates will damage the flight battery. Disconnect and remove the Li-Po battery from the aircraft after use to prevent trickle discharge. During storage, make sure the battery charge does not fall below 3V per cell.

Battery Level Indicator

When first powered on, the quadcopter indicates the charge level of the flight battery by lighting the center LED taillight briefly.

Taillight Color	Battery Charge Level
Green	fully charged
Yellow	partially charged
Red	discharged, do not fly

After the flight battery charge level is shown, the LED taillight indicates the active flight mode or the alternate chosen color as described in the *Changing the Center LED Taillight Color* section.

Changing the Center LED Taillight Color

To change the color of the center LED taillight:

1. Power on the transmitter.
2. Power on the quadcopter. DO NOT arm the motors.
3. Push both transmitter sticks fully forward and hold for 3 seconds. The taillight on the quadcopter will flash continuously.
4. Push the aileron stick right or left to choose the desired taillight color.
5. Pull both transmitter sticks fully back and hold for 1 second to save the desired color. The taillight will now display the chosen color continuously. It will show the active flight mode for approximately 1 second after changing flight modes.

To reset the taillight to the default flight mode indicator color mode:

1. Power on the transmitter.
2. Power on the quadcopter. DO NOT arm the motors.
3. Pull both transmitter sticks fully backward and hold for 5 seconds. The taillight will change color to the active flight mode.

Video System (BNF with FPV)

NOTICE: Consult local laws and ordinances before operating FPV (first person view) equipment. In some areas, FPV operation may be limited or prohibited. You are responsible for operating this product in a legal and responsible manner.

On Screen Display

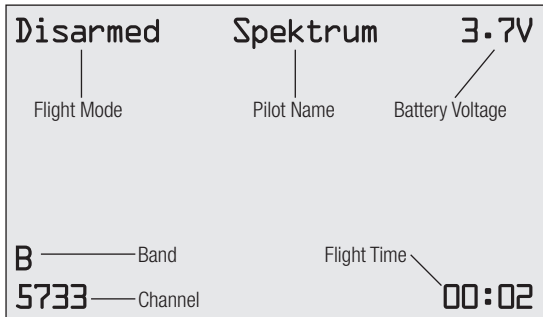

Flight Controller Status

When powering up the aircraft to fly, the OSD will display the flight status in the upper left corner.

When the aircraft has a solid connection to the RC controller, the OSD will display DISARMED

Once the aircraft is armed, the OSD will be display the Flight Mode in the upper left corner.

The video transmitter installed in the BNF FPV version includes an integrated On Screen Display system (OSD). The OSD delivers the pilot useful information on the video display. The OSD shows the Flight Mode, time aloft, and voltage. A call sign is also available on the OSD to display your HAM call sign to satisfy amateur radio rules.

The video transmitter frequency and power output can be set directly from compatible Spektrum transmitters or set in the OSD menu.

OSD Menu

The OSD has a menu system which has options where the pilot can make changes.

1. To enter the menu the motor must be disarmed.
2. Flip the flight mode switch back and forth twice to enter the menu.
3. To navigate the menu use elevator stick to move up and down through the menu, and aileron stick to move side to side through the menu.

Available Frequencies, North America (mHz)

Band	CH 1	CH 2	CH 3	CH 4	CH 5	CH 6	CH 7	CH 8
Band A	5865	5845	5825	5805	5785	5765	5745	5745
Band B	5733	5752	5771	5790	5809	5828	5847	5866
Band E	5705	5685	5665	5665	5885	5905	5905	5905
FS/IRC	5740	5760	5780	5800	5820	5840	5860	5860
RaceBand	5732	5732	5732	5769	5806	5843	5843	5843

Available Frequencies, European Union (mHz)

Band	CH 1	CH 2	CH 3	CH 4	CH 5	CH 6	CH 7	CH 8
Band A	5865	5845	5825	5805	5785	5765	5745	5745
Band B	5733	5752	5771	5790	5809	5828	5847	5866
FS/IRC	5740	5760	5780	5800	5820	5840	5860	5860
RaceBand	5732	5732	5732	5769	5806	5843	5843	5843

Troubleshooting Guide

Problem	Possible Cause	Solution
Will not respond to throttle	Throttle too high and/or throttle trim is too high	Reset controls with the throttle stick and throttle trim at the lowest setting
Does not function and smells burnt after connecting the flight battery	Flight battery connected with the wrong polarity	Replace the 3-in-1 board. Connect the flight battery noting proper polarity
Crashes immediately upon lift-off or doesn't lift off	Propellers in wrong locations	Make necessary adjustments
Static in FPV feed	Interference on chosen channel	Change the video transmitter and receiver channel

Problem	Possible Cause	Solution
LED on receiver flashes rapidly and quadcopter will not respond to transmitter (during binding)	Transmitter too near aircraft during binding process	Power off the transmitter. Move the transmitter a larger distance from the aircraft. Disconnect and reconnect the flight battery to the aircraft. Follow the binding instructions
	Bind switch or button was not held while transmitter was powered on	Power off transmitter and repeat bind process
	Aircraft or transmitter is too close to large metal object, wireless source or another transmitter	Move aircraft and transmitter to another location and attempt binding again

Problem	Possible Cause	Solution
LED on the receiver flashes rapidly and the quadcopter will not respond to the transmitter (after binding)	Less than a 5-second wait between first powering on the transmitter and connecting the flight battery to the quadcopter	Leave the transmitter powered on. Disconnect and reconnect the flight battery to the quadcopter
	The quadcopter is bound to a different model memory (ModelMatch™ transmitters only)	Select the correct model memory on the transmitter. Disconnect and reconnect the flight battery to the quadcopter
	Flight battery or transmitter battery charge is too low	Replace or recharge batteries
	Aircraft or transmitter is too close to large metal object, wireless source or another transmitter	Move aircraft and transmitter to another location and attempt connecting again

Exploded View

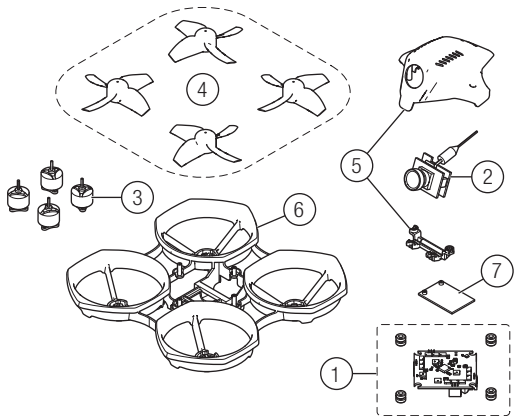

Parts Listings

Part #		Description
1	BLH8851	Main Control Board
2	BLH8852	FPV Camera with OSD
3	BLH8853	Motor (1)
4	BLH8854	Prop Set (4)
5	BLH8855	Canopy
6	BLH8856	Main Frame
7	SPM4647	Receiver

Optional Parts

Part #		Description
FSV1063		Dominator V3 Modular WVGA Headset
FSV1076		Fat Shark Dominator HD3 Headset
SPMVR2510		Focal V2 FPV Wireless Headset w/Diversity
SPMVM430HA		Headset conversion
SPMVR2520		Focal DVR FPV Headset

Limited Warranty

What this Warranty Covers

Horizon Hobby, LLC, (Horizon) warrants to the original purchaser that the product purchased (the "Product") will be free from defects in materials and workmanship at the date of purchase.

What is Not Covered

This warranty is not transferable and does not cover (i) cosmetic damage, (ii) damage due to acts of God, accident, misuse, abuse, negligence, commercial use, or due to improper use, installation, operation or maintenance, (iii) modification of or to any part of the Product, (iv) attempted service by anyone other than a Horizon Hobby authorized service center, (v) Product not purchased from an authorized Horizon dealer, (vi) Product not compliant with applicable technical regulations, or (vii) use that violates any applicable laws, rules, or regulations.

OTHER THAN THE EXPRESS WARRANTY ABOVE, HORIZON MAKES NO OTHER WARRANTY OR REPRESENTATION, AND HEREBY DISCLAIMS ANY AND ALL IMPLIED WARRANTIES, INCLUDING, WITHOUT LIMITATION, THE IMPLIED WARRANTIES OF NON-INFRINGEMENT, MERCHANTABILITY AND FITNESS FOR A PARTICULAR PURPOSE. THE PURCHASER ACKNOWLEDGES THAT THEY ALONE HAVE DETERMINED THAT THE PRODUCT WILL SUITABLY MEET THE REQUIREMENTS OF THE PURCHASER'S INTENDED USE.

Purchaser's Remedy

Horizon's sole obligation and purchaser's sole and exclusive remedy shall be that Horizon will, at its option, either (i) service, or (ii) replace, any Product determined

by Horizon to be defective. Horizon reserves the right to inspect any and all Product(s) involved in a warranty claim. Service or replacement decisions are at the sole discretion of Horizon. Proof of purchase is required for all warranty claims. SERVICE OR REPLACEMENT AS PROVIDED UNDER THIS WARRANTY IS THE PURCHASER'S SOLE AND EXCLUSIVE REMEDY.

Limitation of Liability

HORIZON SHALL NOT BE LIABLE FOR SPECIAL, INDIRECT, INCIDENTAL OR CONSEQUENTIAL DAMAGES, LOSS OF PROFITS OR PRODUCTION OR COMMERCIAL LOSS IN ANY WAY, REGARDLESS OF WHETHER SUCH CLAIM IS BASED IN CONTRACT, WARRANTY, TORT, NEGLIGENCE, STRICT LIABILITY OR ANY OTHER THEORY OF LIABILITY, EVEN IF HORIZON HAS BEEN ADVISED OF THE POSSIBILITY OF SUCH DAMAGES. Further, in no event shall the liability of Horizon exceed the individual price of the Product on which liability is asserted. As Horizon has no control over use, setup, final assembly, modification or misuse, no liability shall be assumed nor accepted for any resulting damage or injury. By the act of use, setup or assembly, the user accepts all resulting liability. If you as the purchaser or user are not prepared to accept the liability associated with the use of the Product, purchaser is advised to return the Product immediately in new and unused condition to the place of purchase.

Law

These terms are governed by Illinois law (without regard to conflict of law principals). This warranty gives you specific legal rights, and you may also have other rights which vary from state to state. Horizon reserves the right to change or modify this warranty at any time without notice.

WARRANTY SERVICES

Questions, Assistance, and Services

Your local hobby store and/or place of purchase cannot provide warranty support or service. Once assembly, setup or use of the Product has been started, you must contact your local distributor or Horizon directly. This will enable Horizon to better answer your questions and service you in the event that you may need any assistance. For questions or assistance, please visit our website at www.horizonhobby.com, submit a Product Support Inquiry, or call the toll free telephone number referenced in the Warranty and Service Contact Information section to speak with a Product Support representative.

Inspection or Services

If this Product needs to be inspected or serviced and is compliant in the country you live and use the Product in, please use the Horizon Online Service Request submission process found on our website or call Horizon to obtain a Return Merchandise Authorization (RMA) number. Pack the Product securely using a shipping carton. Please note that original boxes may be included, but are not designed to withstand the rigors of shipping without additional protection. Ship via a carrier that provides tracking and insurance for lost or damaged parcels, as Horizon is not responsible for merchandise until it arrives and is accepted at our facility. An Online Service Request is available at http://www.horizonhobby.com/content/service-center_render-service-center. If you do not have internet access, please contact Horizon Product Support to obtain a RMA number along with instructions for submitting your product for service. When calling Horizon, you will be asked to provide your complete name, street address, email address and

phone number where you can be reached during business hours. When sending product into Horizon, please include your RMA number, a list of the included items, and a brief summary of the problem. A copy of your original sales receipt must be included for warranty consideration. Be sure your name, address, and RMA number are clearly written on the outside of the shipping carton.

NOTICE: Do not ship LiPo batteries to Horizon. If you have any issue with a LiPo battery, please contact the appropriate Horizon Product Support office.

Warranty Requirements

For Warranty consideration, you must include your original sales receipt verifying the proof-of-purchase date. Provided warranty conditions have been met, your Product will be serviced or replaced free of charge. Service or replacement decisions are at the sole discretion of Horizon.

Non-Warranty Service

Should your service not be covered by warranty, service will be completed and payment will be required without notification or estimate of the expense unless the expense exceeds 50% of the retail purchase cost. By submitting the item for service you are agreeing to payment of the service without notification. Service estimates are available upon request. You must include this request with your item submitted for service. Non-warranty service estimates will be billed a minimum of ½ hour of labor. In addition you will be billed for return freight. Horizon accepts money orders and cashier's checks, as well as Visa, MasterCard, American Express, and Discover cards. By submitting any item to Horizon for service, you are agreeing to Horizon's Terms and Conditions found on our website http://www.horizonhobby.com/content/service-center_render-service-center.

ATTENTION: Horizon service is limited to Product compliant in the country of use and ownership. If received, a non-compliant Product will not be serviced. Further, the sender will be responsible for arranging return shipment of the un-serviced Product, through a carrier of the sender's choice and at the sender's expense. Horizon will hold non-compliant Product for a period of 60 days from notification, after which it will be discarded.

10/15

Warranty and Service Contact Information

United States of America

Horizon Hobby	Contact Information	Address
Horizon Service Center (Repairs and Repair Requests)	servicecenter. horizonhobby.com/ RequestForm/	1608 Interstate Dr. Champaign, Illinois 61822 USA
Horizon Product Support (Product Technical Assistance)	productsupport @horizonhobby.com 877-504-0233	
Sales	websales @horizonhobby.com 800-338-4639	

European Union

Horizon Hobby	Contact Information	Address
Horizon Technischer Service	service@horizonhobby.eu	Hanskampring 9 D 22885 Barsbüttel Germany
Sales: Horizon Hobby GmbH	+49 (0) 4121 2655 100	

FCC Information

FCC ID: BRWBLH8850

This equipment has been tested and found to comply with the limits for Part 15 of the FCC rules. These limits are designed to provide reasonable protection against harmful interference in a residential installation. This equipment generates uses and can radiate radio frequency energy and, if not installed and used in accordance with the instructions, may cause harmful interference to radio communications.

However, there is no guarantee that interference will not occur in a particular installation. If this equipment does cause harmful interference to radio or television reception, which can be determined by turning the equipment off and on, the user is encouraged to try to correct the interference by one or more of the following measures:

- Reorient or relocate the receiving antenna.
- Increase the separation between the equipment and receiver.
- Connect the equipment to an outlet on a circuit different from that to which the receiver is connected.
- Consult the dealer or an experienced radio/TV technician for help.

This device complies with part 15 of the FCC rules. Operation is subject to the following two conditions: (1) This device may not cause harmful interference, and (2) this device must accept any interference received, including interference that may cause undesired operation.

NOTICE: Modifications to this product will void the user's authority to operate this equipment.

Antenna Separation Distance

When operating, please be sure to maintain a separation distance of at least 5 cm between your body (excluding fingers, hands, wrists, ankles and feet) and the antenna to meet RF exposure safety requirements as determined by FCC regulations.

IC Information

IC: 6157A-BLH8850

This device complies with Industry Canada licence-exempt RSS standard(s). Operation is subject to the following two conditions: (1) this device may not cause interference, and (2) this device must accept any interference, including interference that may cause undesired operation of the device."

Compliance Information for the European Union



Inductrix BL BNF Basic (BLH8850)

EU Compliance Statement:

Horizon Hobby, LLC hereby declares that this product is in compliance with the essential requirements and other relevant provisions of the RED Directive.

A copy of the EU Declaration of Conformity is available online at:
<http://www.horizonhobby.com/content/support-render-compliance>.



Instructions for disposal of WEEE by users in the European Union

This product must not be disposed of with other waste. Instead, it is the user's responsibility to dispose of their waste equipment by handing it over to a designated collections point for the recycling of waste electrical and electronic equipment. The separate collection and recycling of your waste equipment at the time of disposal will help to conserve natural resources and make sure that it is recycled in a manner that protects human health and the environment. For more information about where you can drop off your waste equipment for recycling, please contact your local city office, your household waste disposal service or where you purchased the product.



©2018 Horizon Hobby, LLC.

Blade, E-flite, Inductrix, Meow Mode, DSM, DSM2, DSMX, Bind-N-Fly, BNF, the BNF logo, SAFE, ModelMatch, Focal, and the Horizon Hobby logo are trademarks or registered trademarks of Horizon Hobby, LLC.

The Spektrum trademark is used with permission of Bachmann Industries, Inc.

All other trademarks, service marks or logos are property of their respective owners.

Created 07/18

58615

BLH8850