

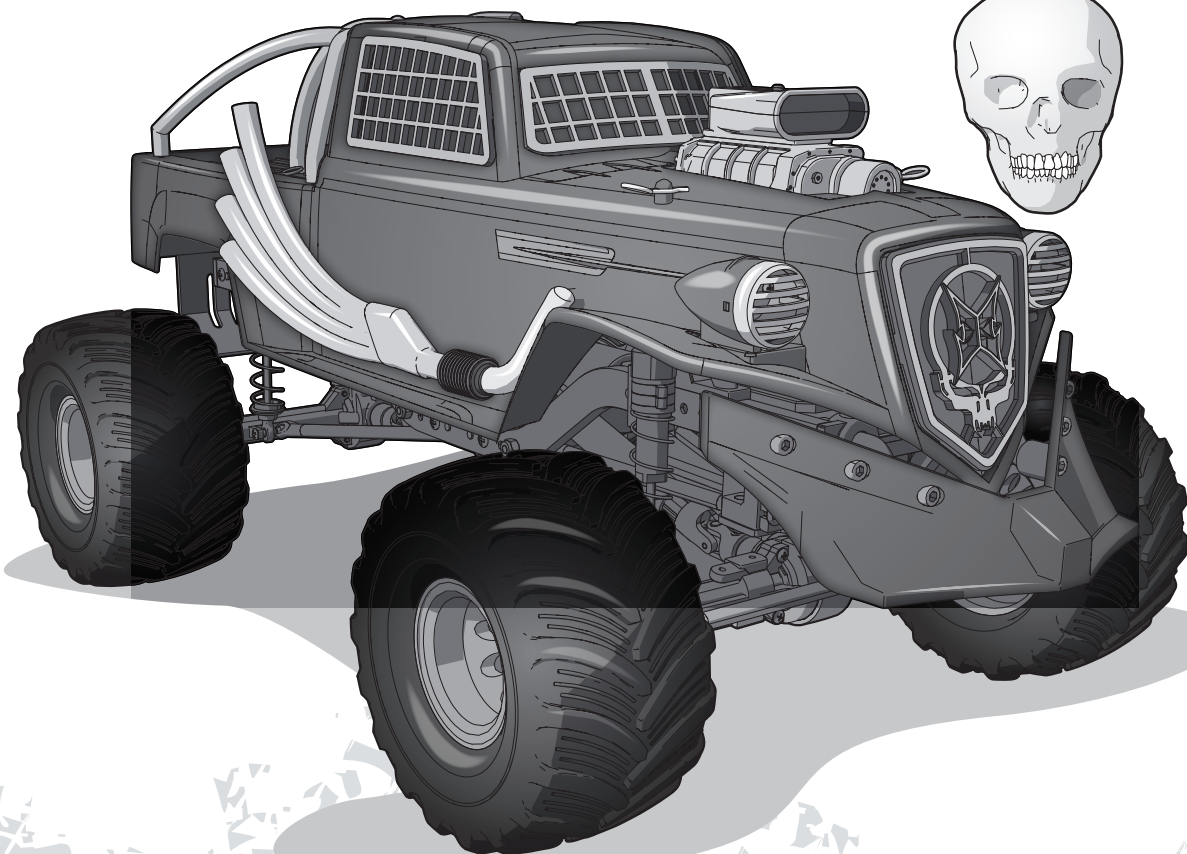

# **BARRAGE** **DOOMSDAY™**



## **1:12-SCALE 4WD BRUSHED RTR**

**ECX01010**

**INSTRUCTION MANUAL**  
**BEDIENUNGSANLEITUNG**  
**MANUEL D'UTILISATION**  
**MANUALE DI ISTRUZIONI**

Congratulations on your purchase of the ECX® Barrage Doomsday™ 1:12 Scale 4WD Brushed RTR. This model introduces you to the sport of RC driving.

Herzlichen Glückwunsch zum Kauf des ECX Barrage Doomsday 1:12 Scale 4WD Brushed RTR. Dieses Modell ist der gelungene Einstieg in die Welt des RC Cars Sports.

Nous vous félicitons pour l'achat de l'ECX Barrage Doomsday 1:12 Scale 4WD Brushed RTR. Ce modèle vous permettra de découvrir l'univers du RC.

Congratulazioni per l'acquisto dell'ECX Barrage Doomsday 1:12 Scale 4WD Brushed RTR. Questo modello dà accesso al mondo degli automodelli radiocomandati.

## NOTICE

All instructions, warranties and other collateral documents are subject to change at the sole discretion of Horizon Hobby, LLC. For up-to-date product literature, visit <http://www.horizonhobby.com> and click on the support tab for this product.

## MEANING OF SPECIAL LANGUAGE

The following terms are used throughout the product literature to indicate various levels of potential harm when operating this product:

**WARNING:** Procedures, which if not properly followed, create the probability of property damage, collateral damage, and serious injury OR create a high probability of superficial injury.

**CAUTION:** Procedures, which if not properly followed, create the probability of physical property damage AND a possibility of serious injury.

**NOTICE:** Procedures, which if not properly followed, create a possibility of physical property damage AND little or no possibility of injury.



**WARNING:** Read the ENTIRE instruction manual to become familiar with the features of the product before operating. Failure to operate the product correctly can result in damage to the product, personal property and cause serious injury.

This is a sophisticated hobby product and NOT a toy. It must be operated with caution and common sense and requires some basic mechanical ability.

Failure to operate this Product in a safe and responsible manner could result in injury or damage to the product or other property. This product is not intended for use by children without direct adult supervision. Do not use with incompatible components or alter this product in any way outside of the instructions provided by Horizon Hobby, LLC. This manual contains instructions for safety, operation and maintenance. It is essential to read and follow all the instructions and warnings in the manual, prior to assembly, setup or use, in order to operate correctly and avoid damage or serious injury.

**Age Recommendation: Not for children under 14 years. This is not a toy.**

## Safety Precautions and Warnings

As the user of this product, you are solely responsible for operating in a manner that does not endanger yourself and others or result in damage to the product or property of others.

This model is controlled by a radio signal subject to interference from many sources outside your control. This interference can cause momentary loss of control, so it is advisable to always keep a safe distance in all directions around your model as this margin will help avoid collisions or injury.

- Never operate your model with low transmitter batteries.
- Always operate your model in open spaces away from full-size vehicles, traffic and people.
- Never operate the model in the street or in populated areas for any reason.
- Carefully follow the directions and warnings for this and any optional support equipment (chargers, rechargeable battery packs, etc.) you use.

- Keep all chemicals, small parts and anything electrical out of the reach of children.
- Never lick or place any portion of the model in your mouth as it could cause serious injury or even death.
- Exercise caution when using tools and sharp instruments.
- Take care during maintenance as some parts may have sharp edges.
- Immediately after using your model, do NOT touch equipment such as the motor, electronic speed control and battery, because they generate high temperatures. You may burn yourself seriously touching them.
- Do not put fingers or any objects inside rotating and moving parts, as this may cause damage or serious injury.
- Always turn on your transmitter before you turn on the receiver in the car. Always turn off the receiver before turning your transmitter off.
- Keep the wheels of the model off the ground when checking the operation of the radio equipment.

## WATER-RESISTANT VEHICLE WITH WATERPROOF ELECTRONICS

Your new Horizon Hobby vehicle has been designed and built with a combination of waterproof and water-resistant components to allow you to operate the product in many "wet conditions," including puddles, creeks, wet grass, snow and even rain.

While the entire vehicle is highly water-resistant, it is not completely waterproof and your vehicle should NOT be treated like a submarine. The various electronic components used in the vehicle, such as the Electronic Speed Control (ESC) and servo(s) are waterproof, however, most of the mechanical components are water-resistant and should not be submerged.

Metal parts, including the bearings, hinge pins, screws and nuts, as well as the contacts in the electrical cables, will be susceptible to corrosion if additional maintenance is not performed after running in wet conditions. To maximize the long-term performance of your vehicle and to keep the warranty intact, the procedures described in the "Wet Conditions Maintenance" section below must be performed regularly if you choose to run in wet conditions. If you are not willing to perform the additional care and maintenance required, then you should not operate the vehicle in those conditions.



**CAUTION:** Failure to exercise caution while using this product and complying with the following precautions could result in product malfunction and/or void the warranty.

### General Precautions

- Read through the wet conditions maintenance procedures and make sure that you have all the tools you will need to properly maintain your vehicle.
- Not all batteries can be used in wet conditions. Consult the battery manufacturer before use. Do not use Li-Po batteries in wet conditions.
- The included transmitter is not waterproof or water-resistant. If using a different transmitter than the one included, consult your transmitter's manual or the manufacturer before operation.
- Never operate your transmitter or vehicle where lightning may be present.
- Do not operate your vehicle where it could come in contact with salt water (ocean water or water on salt-covered roads), contaminated or polluted water. Salt water is very conductive and highly corrosive, so use caution.
- Even minimal water contact can reduce the life of your motor if it has not been certified as water-resistant or waterproof. If the motor becomes excessively wet, apply very light throttle until the water is mostly removed from the motor. Running a wet motor at high speeds may rapidly damage the motor.
- Driving in wet conditions can reduce the life of the motor. The additional resistance of operating in water causes excess strain. Alter the gear ratio by using a smaller pinion or larger spur gear. This will increase torque (and motor life) when running in mud, deeper puddles, or any wet conditions that will increase the load on the motor for an extended period of time.

## Wet Conditions Maintenance

- Remove the battery pack(s) and dry the contacts. If you have an air compressor or a can of compressed air, blow out any water that may be inside the recessed connector housing.
- Remove the tires/wheels from the vehicle and gently rinse the mud and dirt off with a garden hose. Avoid rinsing the bearings and transmission.

**NOTICE:** Never use a pressure washer to clean your vehicle.

- Use an air compressor or a can of compressed air to dry the vehicle and help remove any water that may have gotten into small crevices or corners.

- Spray the bearings, drive train, fasteners and other metal parts with a water-displacing light oil or lubricant. Do not spray the motor.
- Let the vehicle air dry before you store it. Water (and oil) may continue to drip for a few hours.
- Increase the frequency of disassembly, inspection and lubrication of the following:
  - Front and rear axle hub assembly bearings.
  - All transmission cases, gears and differentials.
  - Motor—clean with an aerosol motor cleaner and re-oil the bushings with lightweight motor oil.

## SPECIFICATIONS

### Transmitter

Frequency	2.4GHz
Battery	AA x 4

### Servo

Power Supply	4.8V-6V
Operating Speed	.18 sec/60 degrees @ 4.8V (.15 sec/60 degrees @ 6.0V)
Output Torque	44 oz-in @ 4.8V (54 oz-in @ 6.0V)
Size	40 x 20.3 x 38mm

### Electronic Speed Control (ESC)

Input Voltage	6.0–8.4V
Electric Capacity	60A ESC
PWM Frequency	1kHz
BEC Voltage	5V/2A
Size	46.5 x 34 x 28.5mm
Weight	65 g

## COMPONENTS

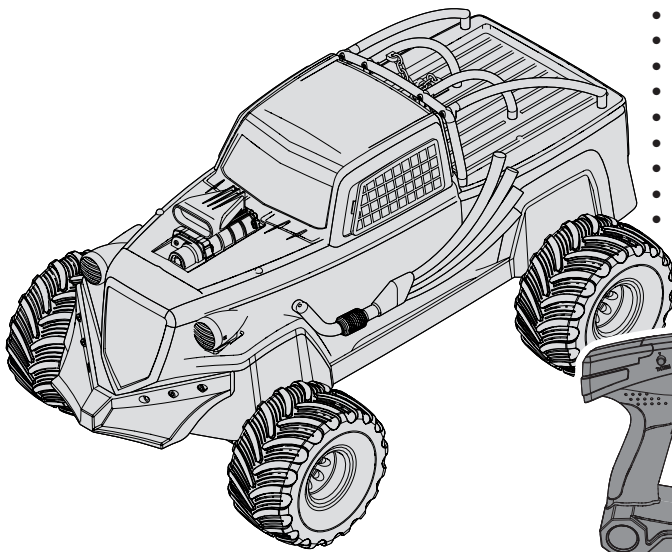

- ECX® Barrage Doomsday™
- ECX® 2.4GHz 2-CH V3 Transmitter
- AA (4) Batteries
- 100mAh NiMH Wall Charger with EC3™ Connector
- Dynamite® Speedpack® 900mAh NiMH battery with EC3™ Connector
- Dynamite® Tazer™ 390 Brushed Motor
- Dynamite® 60A WP FWD/REV Brushed ESC
- ECX® 2.4GHz 2-CH V3 Receiver
- Spektrum™ Digital Servo

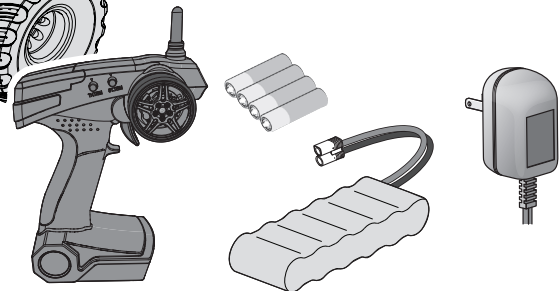

## TABLE OF CONTENTS

Quick Start.....	4	Maintenance .....	8
Vehicle Preparations .....	4	Setting the Gear Mesh.....	8
Charging the Vehicle Battery .....	4	Electronic Speed Control (ESC).....	8
Charging Warnings .....	4	Troubleshooting Guide .....	9
Installing the Battery.....	5	Limited Warranty .....	10
Transmitter Controls.....	5	Warranty and Service Contact Information .....	11
Installing Transmitter Batteries .....	5	FCC Information.....	11
Binding .....	6	IC Information.....	11
Getting Started.....	6	Replacement Parts .....	40–41
Operation.....	7	Optional Parts.....	41
When You Are Finished.....	7	Parts Diagram.....	42–46
Motor Care .....	7		

## QUICK START

Please read the entire manual to gain a full understanding of the vehicle, fine-tuning the setup and performing maintenance.

1. Read the safety precautions found in this manual.
2. Charge a battery for the vehicle. Refer to the included charging warnings and instructions for battery charging information.
3. Install the AA batteries in the transmitter. Only use alkaline or rechargeable batteries.
4. Install the fully charged battery in the vehicle.
5. Power ON the transmitter and then the vehicle. Wait 5 seconds for the ESC to initialize. Always power the transmitter ON before the vehicle and power it OFF after the vehicle has been powered OFF.
6. Check the steering and throttle control directions. Verify that the servos are moving in the correct direction.
7. Drive your vehicle.
8. Perform any necessary maintenance.

## VEHICLE PREPARATIONS

### CHARGING THE VEHICLE BATTERY

**NOTICE:** Never charge a battery in the vehicle or damage may result.

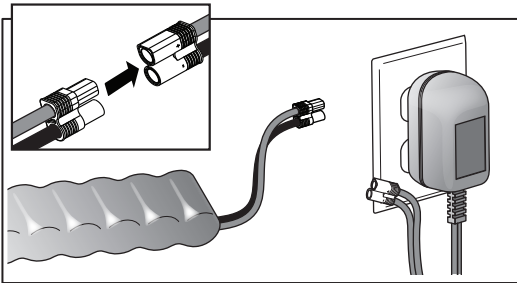

1. Connect the NiMH battery to the battery charger.
2. Connect the charger to an AC power outlet.
3. Allow the NiMH battery to charge for 9 hours.

### CHARGING WARNINGS

**WARNING:** Failure to exercise caution while using this product and comply with the following warnings could result in product malfunction, electrical issues, excessive heat, FIRE, and ultimately injury and property damage.

- **NEVER LEAVE CHARGING BATTERIES UNATTENDED.**
- **NEVER CHARGE BATTERIES OVERNIGHT.**
- Read all safety precautions and literature prior to use of this product.
- Never leave the battery and charger unattended during use.
- Never allow children under 14 years of age to charge battery packs.
- Never attempt to charge dead or damaged batteries.
- Never charge a battery if the cable has been pinched or shorted.
- Never allow batteries or charger to come into contact with moisture at any time.
- Never charge batteries in extremely hot or cold places (recommended between 50–80°F [10–26°C]) or place in direct sunlight.
- Always use only Ni-MH rechargeable batteries. This charger cannot charge batteries such as “heavy duty,” “alkaline,” “mercury” or “lithium” battery.
- Always connect to the charger correctly.
- Always disconnect the battery and charger after charging and let them cool between charges.
- Always inspect the battery before charging.
- Always terminate all processes and contact Horizon Hobby if the product malfunctions.
- Always make sure you know the specifications of the battery to be charged or discharged to ensure it meets the requirements of this charger.
- Always constantly monitor the temperature of the battery pack while charging.
- Always end the charging process if the charger or battery becomes hot to the touch or starts to change form during the charge process.
- Always charge in a well ventilated area.

## INSTALLING THE BATTERY

1. Remove the vehicle body.
2. Install a fully charged battery.
3. Secure the battery pack using the hook and loop straps.
4. Connect the battery pack to the ESC power connector.

**CAUTION:** Connecting the battery to the ESC with reversed polarity will cause damage to the ESC, the battery or both. Damage caused by incorrectly connecting the battery is not covered under warranty.

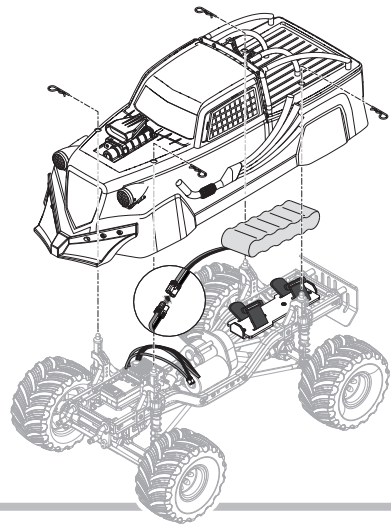

## TRANSMITTER CONTROLS

**BATTERY LEVEL INDICATOR**

**Solid Red and Green:** Battery voltage is good (above 4V).

**Solid Red:** Battery voltage is critically low (below 4V). Replace transmitter batteries.

**THROTTLE DUAL RATE**

Adjusts the maximum amount of throttle the vehicle can be given

**STEERING DUAL RATE**

Adjusts the amount the steering moves when the steering wheel is turned left or right

**THROTTLE TRIM**

Adjusts the neutral point of the electronic speed control

**STEERING TRIM**

Adjust to make the vehicle drive straight with no input at the steering wheel

**REVERSE SWITCH**

Allows you to change the direction of steering (ST. REV) and throttle (TH. REV) controls (Ensure proper function with a radio system test).

**POWER SWITCH**

Power on or off the transmitter

**STEERING WHEEL**

Control steering. Right and Left steering

**THROTTLE TRIGGER**

Controls power to the motor for forward or reverse

Forward Stop Reverse

## INSTALLING TRANSMITTER BATTERIES

This transmitter requires 4 AA batteries.

1. Remove the battery cover from the transmitter.
2. Install the batteries as shown.
3. Install the battery cover.

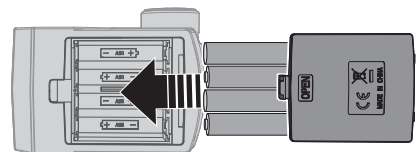

**CAUTION:** If using rechargeable batteries, charge only rechargeable batteries. Charging non-rechargeable batteries may cause the batteries to burst, resulting in injury to persons and/or damage to property.

**CAUTION:** Risk of explosion if battery is replaced by an incorrect type. Dispose of used batteries according to national regulations.

## BINDING

The included transmitter and receiver are bound at the factory.

If you need to rebind, follow the instructions below.

1. Power off the transmitter and ESC.
2. Connect a fully charged battery pack to the ESC.
3. Power on the ESC. The RED LED on the receiver flashes.
4. Press and release the bind button (A) on the receiver. The RED LED on the receiver flashes rapidly.
5. Power on the transmitter.
6. The RED LED on the receiver turns solid when the radio system is bound.

You must rebind when binding the receiver to a different transmitter.

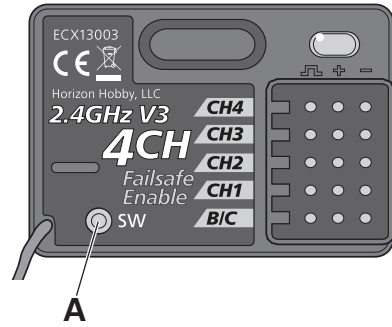

**NOTICE:** Do not attempt to bind the transmitter and receiver if there are other compatible transmitters in bind mode within 400 feet. Doing so may result in unexpected binding.

## GETTING STARTED

1. Power on the transmitter.

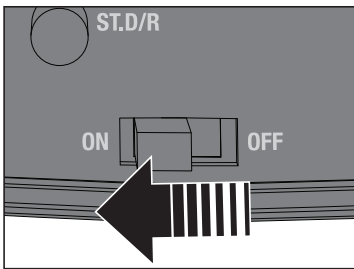

2. Connect the battery to the Electronic Speed Control (ESC) / Receiver unit and power on the vehicle.

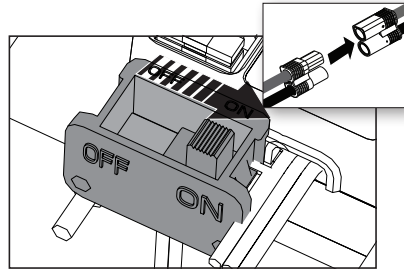

3. Perform a test of the transmitter's control of the vehicle with the vehicle's wheels off the ground.

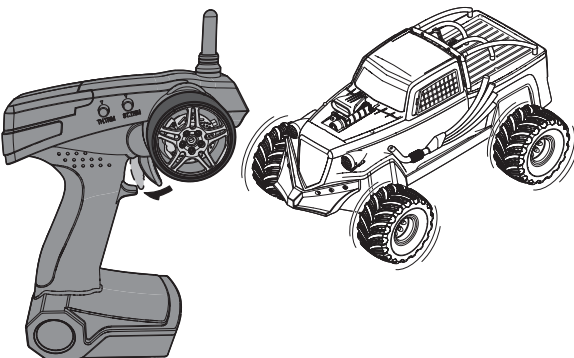

4. Start driving slowly, and, if the vehicle does not go straight, adjust the steering trim dial on the transmitter.

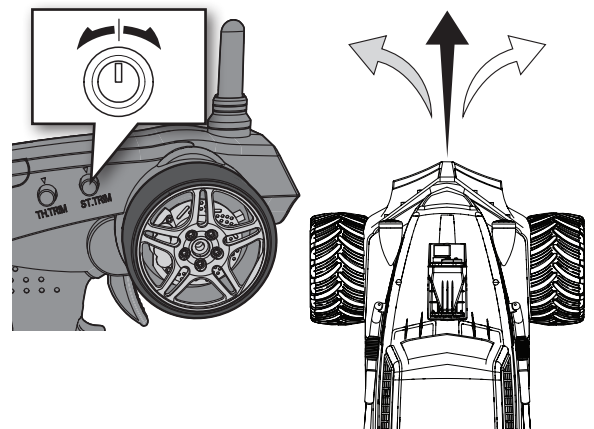

**IMPORTANT:** Seat the motor brushes by driving smoothly on a flat surface during use of the first battery charge. Properly seating the motor brushes will increase the life and performance of the motor.

## OPERATION

- ALWAYS turn on your transmitter before you turn on the receiver in the vehicle. Always power off the receiver before turning your transmitter off.
- ALWAYS operate your vehicle in a wide open area. Operating the vehicle in a small space or indoors can cause overheating at low speeds. Operating at low speed increases heat in the electronic speed control (ESC). Overheating can damage the vehicle and failure may result.

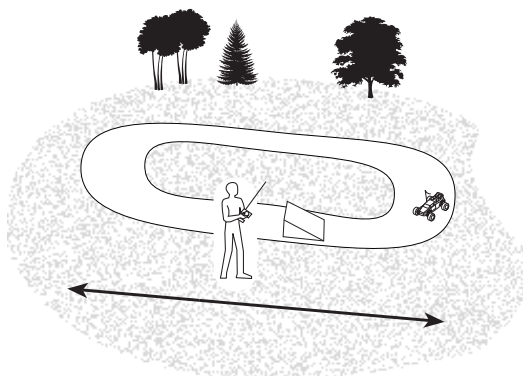
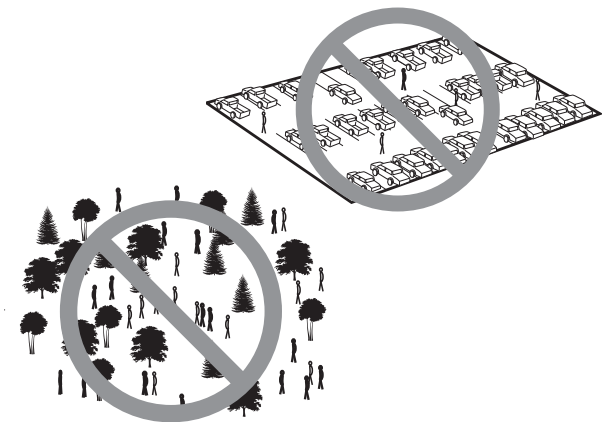

## WHEN YOU ARE FINISHED

1. Power off the ESC.

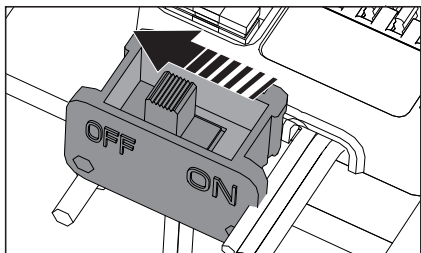

2. Disconnect the battery.

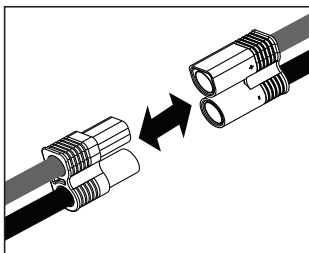

3. Power off the transmitter.

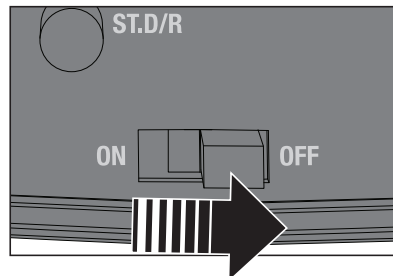

4. Remove the battery from the vehicle.

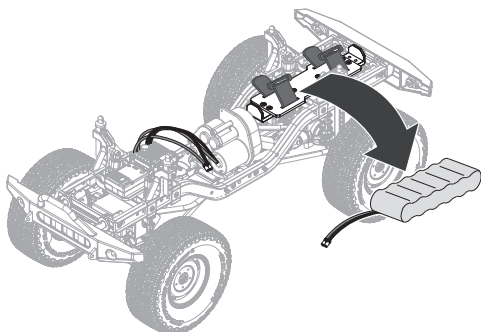

5. Recharge the battery.

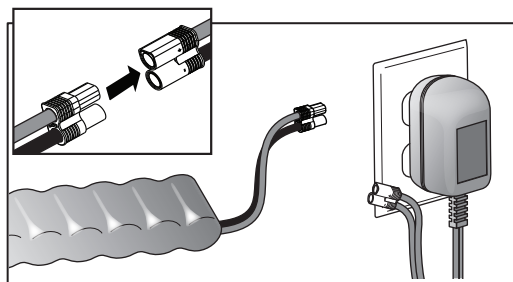

## MOTOR CARE

- Seat the motor brushes by driving smoothly on a flat surface during use of the first battery charge. **Failing to do so can greatly reduce motor performance and functional life.**
- Prolong motor life by preventing overheating conditions. Undue motor wear results from frequent turns, stops and starts, pushing objects, driving in deep water and tall grass, and driving continuously up hill. **Allow the motor to cool completely before running the vehicle.**
- Over-temperature protection is installed on the ESC to prevent circuit damage, but cannot protect the motor from driving against heavy resistance.

## MAINTENANCE

### SETTING THE GEAR MESH

The gear mesh has already been set at the factory. Setting the gear mesh is only necessary when changing motors or gears.

You must remove the vehicle's gear cover (A) to make this adjustment.

Proper gear mesh (how the gear teeth meet) is important to the performance of the vehicle. When the gear mesh is too loose, the spur gear could be damaged by the pinion gear of the motor. If the mesh is too tight, speed could be limited and the motor and ESC will overheat. Set the gear mesh by following these simple steps:

1. Loosen the 2 motor screws (B).
2. Put a small piece of paper (C) between the pinion and spur gears.
3. Push the gears together while tightening the motor screws.

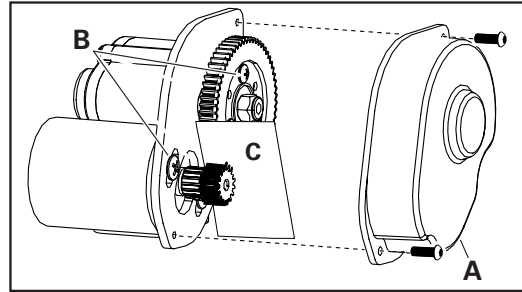

4. Rotate the gears to remove the paper. The gearing should move a small amount.
5. Reinstall the gear cover.

### ELECTRONIC SPEED CONTROL (ESC)

#### Connecting

1. Connect the RED (+) ESC wire to the RED (+) motor wire.
2. Connect the BLACK (-) ESC wire to the BLACK (-) motor wire.

**NOTICE:** Always disconnect the battery from the ESC when you have finished operating your vehicle. The ESC's switch only controls power to the receiver and servos. The ESC will continue to draw current when connected to the battery, resulting in possible damage to the battery through over-discharge.

#### Calibrating

Ensure proper ESC function by calibrating the ESC to your transmitter inputs.

1. Power OFF the ESC.
2. Ensure your transmitter is powered ON, the throttle is not reversed, the throttle trim is neutral and the throttle travel range is at 100%.
3. Keep the throttle at neutral and power ON the ESC.
4. The ESC automatically calibrates the throttle range after 3 seconds.
5. One long beep will sound when the ESC is ready to run.

#### Programming

The ESC comes with two jumpers pre-installed in the MODE: Forward/Brake/Reverse and BATT: Ni-MH configurations.

To change the mode to F/B/R (forward/brake/reverse) or F/R (forward/reverse) or change the battery type to Li-Po:

1. Power OFF the ESC.
2. Disconnect the jumper from the default port and connect it to the desired port.
3. Power ON the ESC.

If the jumpers are lost or not installed, the ESC will default to MODE: F/B/R and BATT: Li-Po.

**WARNING:** Do not connect bind plugs or receiver servo leads into the ESC programming port. Doing so may damage the ESC and/or components.

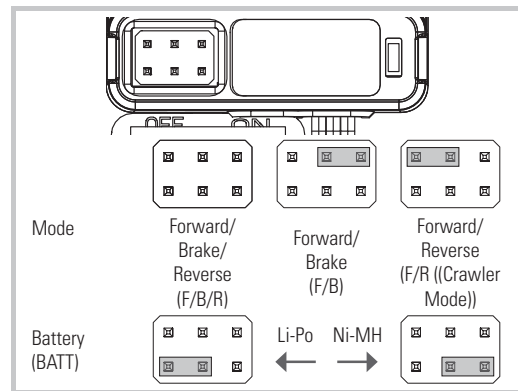



## TROUBLESHOOTING GUIDE

Problem	Possible Cause	Solution
Short Run Time	Battery damaged/not charged	Check/change battery
	Motor dirty	Check/clean
Sluggish Action	Motor dirty	Check/clean
	Bind in drivetrain	Clean/adjust
	Vehicle battery is not charged	Replace/recharge
Controls Reversed	ST. REV or TH. REV	Change switch position
Does Not Operate	Transmitter batteries low	Replace/recharge
	Transmitter powered off	Power on
	ESC powered off	Power on
	Vehicle battery is not charged	Replace/recharge
	Dual-rate (D/R) steering and/or throttle knobs on transmitter are turned to zero	Adjust dual-rate (D/R) steering and/or throttle knobs to 10
Poor Range	Transmitter batteries low	Replace/recharge
	Receiver antenna damaged	Check/repair/replace
The system will not connect	Transmitter and receiver too near each other	Move transmitter 3.3–9.8ft (1–3m) from receiver
	Transmitter and receiver too near large metal objects (vehicles, etc.)	Move away from large metal objects (vehicles, etc.)
	Throttle trim out of center on transmitter	Set throttle trim on transmitter to zero. Turn off and on transmitter and vehicle
	Receiver accidentally put in bind mode so receiver is no longer bound	Rebind transmitter and receiver
The receiver goes into failsafe mode a short distance away from the transmitter	Check the receiver antenna to be sure it is not cut or damaged	Make sure the antenna is in the antenna tube Contact Horizon Product Support
The receiver quits responding during operation	Low battery voltage	Completely recharge battery
	Loose or damaged wires or connectors between battery and receiver	Do a check of the wires and connection between battery and receiver. Repair or replace wires and/or connectors
Receiver and transmitter are not bound	Transmitter accidentally put in bind mode, ending bind to receiver	Bind transmitter to receiver
Vehicle moves forward or backward without input from user	Throttle trim on transmitter not centered	Adjust throttle trim to set neutral point
Car does not drive straight	Steering trim on transmitter not centered	Adjust steering trim so vehicle drives straight
No steering or lack of steering	Steering dual-rate (D/R) not adjusted correctly	Adjusts steering dual-rate (D/R) knob on transmitter to desired steering throw
	Servo failed	Contact Horizon Product Support
No throttle or lack of throttle	Throttle dual-rate (D/R) not adjusted correctly	Adjust the throttle dual-rate (D/R) knob on transmitter to desired steering throw
	ESC failed	Contact Horizon Product Support
	Motor failed	Contact Horizon Product Support
Clicking noise in transmission area	Dirt or rocks in spur gear	Remove gear cover and inspect. If necessary, replace gear
	Motor moved away from spur gear	Reset gear mesh

## LIMITED WARRANTY

### What this Warranty Covers

Horizon Hobby, LLC, (Horizon) warrants to the original purchaser that the product purchased (the "Product") will be free from defects in materials and workmanship at the date of purchase.

### What is Not Covered

This warranty is not transferable and does not cover (i) cosmetic damage, (ii) damage due to acts of God, accident, misuse, abuse, negligence, commercial use, or due to improper use, installation, operation or maintenance, (iii) modification of or to any part of the Product, (iv) attempted service by anyone other than a Horizon Hobby authorized service center, (v) Product not purchased from an authorized Horizon dealer, or (vi) Product not compliant with applicable technical regulations or (vii) use that violates any applicable laws, rules, or regulations.

OTHER THAN THE EXPRESS WARRANTY ABOVE, HORIZON MAKES NO OTHER WARRANTY OR REPRESENTATION, AND HEREBY DISCLAIMS ANY AND ALL IMPLIED WARRANTIES, INCLUDING, WITHOUT LIMITATION, THE IMPLIED WARRANTIES OF NON-INFRINGEMENT, MERCHANTABILITY AND FITNESS FOR A PARTICULAR PURPOSE. THE PURCHASER ACKNOWLEDGES THAT THEY ALONE HAVE DETERMINED THAT THE PRODUCT WILL SUITABLY MEET THE REQUIREMENTS OF THE PURCHASER'S INTENDED USE.

### Purchaser's Remedy

Horizon's sole obligation and purchaser's sole and exclusive remedy shall be that Horizon will, at its option, either (i) service, or (ii) replace, any Product determined by Horizon to be defective. Horizon reserves the right to inspect any and all Product(s) involved in a warranty claim. Service or replacement decisions are at the sole discretion of Horizon. Proof of purchase is required for all warranty claims. SERVICE OR REPLACEMENT AS PROVIDED UNDER THIS WARRANTY IS THE PURCHASER'S SOLE AND EXCLUSIVE REMEDY.

### Limitation of Liability

HORIZON SHALL NOT BE LIABLE FOR SPECIAL, INDIRECT, INCIDENTAL OR CONSEQUENTIAL DAMAGES, LOSS OF PROFITS OR PRODUCTION OR COMMERCIAL LOSS IN ANY WAY, REGARDLESS OF WHETHER SUCH CLAIM IS BASED IN CONTRACT, WARRANTY, TORT, NEGLIGENCE, STRICT LIABILITY OR ANY OTHER THEORY OF LIABILITY, EVEN IF HORIZON HAS BEEN ADVISED OF THE POSSIBILITY OF SUCH DAMAGES. Further, in no event shall the liability of Horizon exceed the individual price of the Product on which liability is asserted. As Horizon has no control over use, setup, final assembly, modification or misuse, no liability shall be assumed nor accepted for any resulting damage or injury. By the act of use, setup or assembly, the user accepts all resulting liability. If you as the purchaser or user are not prepared to accept the liability associated with the use of the Product, purchaser is advised to return the Product immediately in new and unused condition to the place of purchase.

### Law

These terms are governed by Illinois law (without regard to conflict of law principals). This warranty gives you specific legal rights, and you may also have other rights which vary from state to state. Horizon reserves the right to change or modify this warranty at any time without notice.

### WARRANTY SERVICES

#### Questions, Assistance, and Services

Your local hobby store and/or place of purchase cannot provide warranty support or service. Once assembly, setup or use of the Product has been started, you must contact your local distributor or Horizon directly. This will enable Horizon to better answer your questions and service you in the event

that you may need any assistance. For questions or assistance, please visit our website at [www.horizonhobby.com](http://www.horizonhobby.com), submit a Product Support Inquiry, or call the toll free telephone number referenced in the Warranty and Service Contact Information section to speak with a Product Support representative.

### Inspection or Services

If this Product needs to be inspected or serviced and is compliant in the country you live and use the Product in, please use the Horizon Online Service Request submission process found on our website or call Horizon to obtain a Return Merchandise Authorization (RMA) number. Pack the Product securely using a shipping carton. Please note that original boxes may be included, but are not designed to withstand the rigors of shipping without additional protection. Ship via a carrier that provides tracking and insurance for lost or damaged parcels, as Horizon is not responsible for merchandise until it arrives and is accepted at our facility. An Online Service Request is available at [http://www.horizonhobby.com/content/service-center\\_render-service-center](http://www.horizonhobby.com/content/service-center_render-service-center). If you do not have internet access, please contact Horizon Product Support to obtain a RMA number along with instructions for submitting your product for service. When calling Horizon, you will be asked to provide your complete name, street address, email address and phone number where you can be reached during business hours. When sending product into Horizon, please include your RMA number, a list of the included items, and a brief summary of the problem. A copy of your original sales receipt must be included for warranty consideration. Be sure your name, address, and RMA number are clearly written on the outside of the shipping carton.

**NOTICE: Do not ship Li-Po batteries to Horizon. If you have any issue with a Li-Po battery, please contact the appropriate Horizon Product Support office.**

### Warranty Requirements

**For Warranty consideration, you must include your original sales receipt verifying the proof-of-purchase date.** Provided warranty conditions have been met, your Product will be serviced or replaced free of charge. Service or replacement decisions are at the sole discretion of Horizon.

### Non-Warranty Service

**Should your service not be covered by warranty, service will be completed and payment will be required without notification or estimate of the expense unless the expense exceeds 50% of the retail purchase cost.** By submitting the item for service you are agreeing to payment of the service without notification. Service estimates are available upon request. You must include this request with your item submitted for service. Non-warranty service estimates will be billed a minimum of ½ hour of labor. In addition you will be billed for return freight. Horizon accepts money orders and cashier's checks, as well as Visa, MasterCard, American Express, and Discover cards. By submitting any item to Horizon for service, you are agreeing to Horizon's Terms and Conditions found on our website [http://www.horizonhobby.com/content/service-center\\_render-service-center](http://www.horizonhobby.com/content/service-center_render-service-center).

**ATTENTION: Horizon service is limited to Product compliant in the country of use and ownership. If received, a non-compliant Product will not be serviced. Further, the sender will be responsible for arranging return shipment of the un-serviced Product, through a carrier of the sender's choice and at the sender's expense. Horizon will hold non-compliant Product for a period of 60 days from notification, after which it will be discarded.**

10/15

## WARRANTY AND SERVICE CONTACT INFORMATION

Country of Purchase	Horizon Hobby	Contact Information	Address
United States of America	Horizon Service Center (Repairs and Repair Requests)	servicecenter.horizonhobby.com/ RequestForm/	4105 Fieldstone Rd Champaign, Illinois, 61822 USA
	Horizon Product Support (Product Technical Assistance)	productsupport@horizonhobby.com 877-504-0233	
	Sales	websales@horizonhobby.com 800-338-4639	
European Union	Horizon Technischer Service	service@horizonhobby.eu	Hanskampring 9 D 22885 Barsbüttel, Germany
	Sales: Horizon Hobby GmbH	+49 (0) 4121 2655 100	

## FCC INFORMATION

**FCC ID: BRWECX13002** This device complies with part 15 of the FCC rules. Operation is subject to the following two conditions: (1) This device may not cause harmful interference, and (2) this device must accept any interference received, including interference that may cause undesired operation.



**CAUTION:** Changes or modifications not expressly approved by the party responsible for compliance could void the user's authority to operate the equipment.

This product contains a radio transmitter with wireless technology which has been tested and found to be compliant with the applicable regulations governing a radio transmitter in the 2.400GHz to 2.4835GHz frequency range.

### Antenna Separation Distance

When operating your Spektrum transmitter, please be sure to maintain a separation distance of at least 5 cm between your body (excluding fingers, hands, wrists, ankles and feet) and the antenna to meet RF exposure safety requirements as determined by FCC regulations.

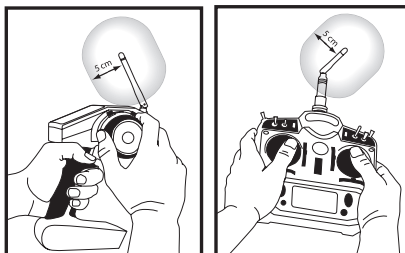

The following illustrations show the approximate 5 cm RF exposure area and typical hand placement when operating your Spektrum transmitter.

The following illustrations show the approximate 5 cm RF exposure area and typical hand placement when operating your Spektrum transmitter.

## IC INFORMATION

**IC ID: 6157A-ECX13002** This device complies with Industry Canada license-exempt RSS standard(s). Operation is subject to the following two conditions:

(1) this device may not cause interference, and (2) this device must accept any interference, including interference that may cause undesired operation of the device.



**EU Compliance Statement:** Horizon Hobby, LLC hereby declares that this product is in compliance with the essential requirements and other relevant provisions of the RED, EMC, and LVD Directives.

A copy of the EU Declaration of Conformity is available online at: <http://www.horizonhobby.com/content/support-render-compliance>.



### Instructions for disposal of WEEE by users in the European Union

This product must not be disposed of with other waste. Instead, it is the user's responsibility to dispose of their waste equipment by handing it over to a designated collection point for the recycling of waste electrical and electronic equipment. The separate collection and recycling of your waste equipment at the time of disposal will help to conserve natural resources and ensure that it is recycled in a manner that protects human health and the environment. For more information about where you can drop off your waste equipment for recycling, please contact your local city office, your household waste disposal service or where you purchased the product.

## Replacement Parts / Ersatzteile / Pièces de rechange / Pezzi di ricambio

Part #	Description	Beschreibung	Description	Descrizione
DYNS1206	Tazer 390 Motor	Motor: Tazer 370	Moteur: Tazer 370	Motore: Tazer 370
DYNS2210	WP 60A Bürstenregler Vorwärts/ rückwärts	WP 60A FWD/REV Brushed ESC	WP 60A Contrôleur à balais avant/arrière	WP 60A ESC con spazzole avanti/ indietro
ECX1015	5x10x4mm Ball Bearing (8)	Kugellager 5x10x4mm (8)	Roulements 5x10x4mm (8)	Cuscinetto a sfera 5x10x4mm (8)
ECX13002	2.4GHz Surface TX, 2-CH, V3	2.4GHz 2 Kanal Sender V3	2.4GHz Emetteur 2 voies, V3	2-Ch trasmettitore, V3
ECX13003	2.4GHz RX Waterproof, 2-Channel V3	2.4GHz 2 Kanal Empfänger wasserfesten V3	2.4GHz Récepteur étanche 2 voies V3	2.4GHz ricevitore impermeabile 2Ch, V3
ECX211015	Bumper Mount	Stoßfängerhalter	Support de pare-choc	Supporto paraurti
ECX211016	Chassis Set	Chassis	Châssis	Set telaio
ECX211017	Skid Plate	Unterfahrschutz	Plaques de protection	Piastra di protezione
ECX211018	Shock Tower	Dämpferbrücke:	Support d'amortisseurs	Torre ammortizz.
ECX211019	Body Post	Karosseriehalter	Supports de carrosserie	Supporti carrozzeria
ECX211020	Chassis Brace (2)	Chassishalter (2)	Renforts de châssis (2)	Rinforzo telaio (2)
ECX211021	ESC & Battery Tray	Regler und akkuhalter	Support de batterie et contrôleur	Supporto batteria e ESC
ECX212009	Spool 38T	Spool 38T	Spool 38T	Corona 38T
ECX212010	Axle Pinion Gear 14T	Ritzel 14T	Pignon 14T	Pignone 14T
ECX212018	Spur Gear 48P 60T (1)	Hauptzahnrad 48P 60T (1)	Couronne 48P 60T (1)	Corona 48P 60T (1)
ECX212020	Transmission Outdrive	Antriebsklauen	Noix de sortie de transmission	Bicchierini trasmissione
ECX212021	Driveshaft (2)	Antriebswelle (2)	Cardan (2)	Albero trasmissione (2)
ECX212022	Rear Hub (2)	Radträger Hinten (2)	Fusée arrière (2)	Mozzo posteriore (2)
ECX212027	Steering Spindle V2	Lenkspindel V2	Set de fusées V2	Fusello sterzo V2
ECX212028	Front/Rear Hub Set, V2	Träger Set Vorne/Hinten, V2	Set d'étriers Av/Arr, V2	Set hub ant/post, V2
ECX213002	F/R Shocks Assembled (2):	Dämpfer montiert Vorne/Hinten (2):	Amortisseurs Av/Arr assemblés (2)	Ammortizzatori montati ant/post (2)
ECX216003	Complete Hardware Set	Kompletter Hardwareersatz	Ensemble de matériel complet	Set bulloneria completo
ECX217001	Spindle/Hub Bearing Set	ECX Spindelset/Lagerset	Set de roulements de fusées	Set supporto fusello/hub
ECX220000	Cage, Window & Bumper Mount	Käfig, Fenster und Stoßstangenbefestigung	Cage, support de pare-chocs et fenêtre	Supporto ammortizzatore, finestrino e gabbia
ECX220001	Motor, Exhaust, Grill Parts	Motor, Auslass, Kühlergrillbauteile	Moteur, échappement et pièces de grille	Parti griglia, scarico e motore
ECX220002	Front Bumper & Headlight, Black	Frontstoßstange und Scheinwerfer, schwarz	Pare-chocs avant et phare, noirs	Faro e ammortizzatore anteriore, nero
ECX220003	Body, Black/Copper	Karosserie, schwarz/kupfer	Carrosserie, noir/cuivre	Corpo, nero/rame
ECX220008	LED Replacement, Orange	LED-Ersatz, Orange	LED de rechange, Orange	LED di rimpiazzo, Arancione
ECX221000	Servo mount and plate, wheel hex, & pin	Servohalterung und Platte, Sechskantrad und Stift	Support de servo et plaque, hexagone de roue et broche	Piastra e supporto servocomando, ruota esagonale e perno
ECX221001	Rear Bumper, Alum	Heckstoßstange, Aluminium	Pare-chocs arrière, aluminium	Ammortizzatore posteriore, alum
ECX222000	FR/RR Axle Housing, 132mm	FR/RR-Achsgehäuse, 132 mm	Carter d'essieu avant/arrière, 132mm	Carcassa assale FR/RR, 132 mm
ECX222001	390 Motor Plate	390 Motorplatte	Plaque moteur 390	Piastra motore 390
ECX222002	FR/RR Axles	FR/RR-Achse	Essieux avant/arrière	Assali FR/RR
ECX222003	Complete Transmission	Komplettes Getriebe	Transmission complète	Trasmissione completa
ECX222004	FR/RR Tire, Prmnt (2)	FR/RR-Rad, vormontiert (2)	Pneu avant/arrière, prémonté (2)	Ruota FR/RR, Prmnt (2)
ECX224000	Link Set	Verbindungssatz	Jeu de liens	Set leveraggi
SPMS602	S602 Digital Servo	S602 Digital Servo	Servo digital S602	S602 Digital Servo

## Optional Parts / Optionale Teile / Liste des options / Elenco parti opzionali

Part #	Description	Beschreibung	Description	Descrizione
DYN1471	7.2V 1750mAh NiMH 6C Flat Battery, EC3: Minis	Flache Akkus Ni-MH 7,2V 1750mA, EC3: Mini 1/18	Mini 1/18: Batterie plate Ni-MH 7,2V 1750mA, prise EC3	Batteria piatta 6C NiMH 1750 mAh 7,2 V, EC3: Minis
DYN1473	7.2V 1200mAh Ni-MH Battery, Long w/EC3: Minis	Lange Akkus Ni-MH 7,2V 1750mA, EC3: Mini 1/18	Mini 1/18: Batterie longue Ni-MH 7,2V 1200mA, prise EC3	Batteria lunga NiMH 1200 mAh 7,2 V c/ EC3: Minis
DYN1476	7.4V 2000mAh 2S30C LiPo, Long, EC3	7,4 V 2000 mA 2S30C LiPo, lang, EC3	Batterie LiPo 7.4V 2000mAh 2S 30C, longue, EC3	7,4 V 2000 mAh 2S30C LiPo, Lunga, EC3
DYNC2000CA	Prophet Sport NiMH 35W AC Charger	Prophet Sport NiMH 35W AC-Ladegerät	Chargeur Prophet Sport AC Ni-MH 35W	Caricabatteria AC Prophet Sport NiMH 35 W
ECX220004	Cir Body, Precut	Gehäuse, vorgeschnitten	Carrosserie prédécoupée	Corpo cir, pretagliato
ECX220005	Motor, Exhaust & Grill Parts, Black	Motor, Auslass und Kühlergrillbauteile, schwarz	Moteur, échappement et pièces de grille, noirs	Parti griglia, scarico e motore, nero
ECX220006	Front Bumper & Headlight, Black	Frontstoßstange und Scheinwerfer, schwarz	Pare-chocs avant et phare, noirs	Faro e ammortizzatore anteriore, nero
ECX312005	Rear Hub Carrier, Alum	Hinterer Nabenträger, Aluminium	Porte-moyeu arrière, aluminium	Supporto mozzo posteriore, alum
ECX314005	Steering Spindle, Alum	Lenkspindel, Aluminium	Arbre de direction, aluminium	Colonna dello sterzo, alum

**PARTS DIAGRAM | EXPLOSIONSZEICHNUNG | VUE ÉCLATÉE DES PIÈCES |  
ESPLOSO DEL MODELLO CON REFERENZA PEZZI**

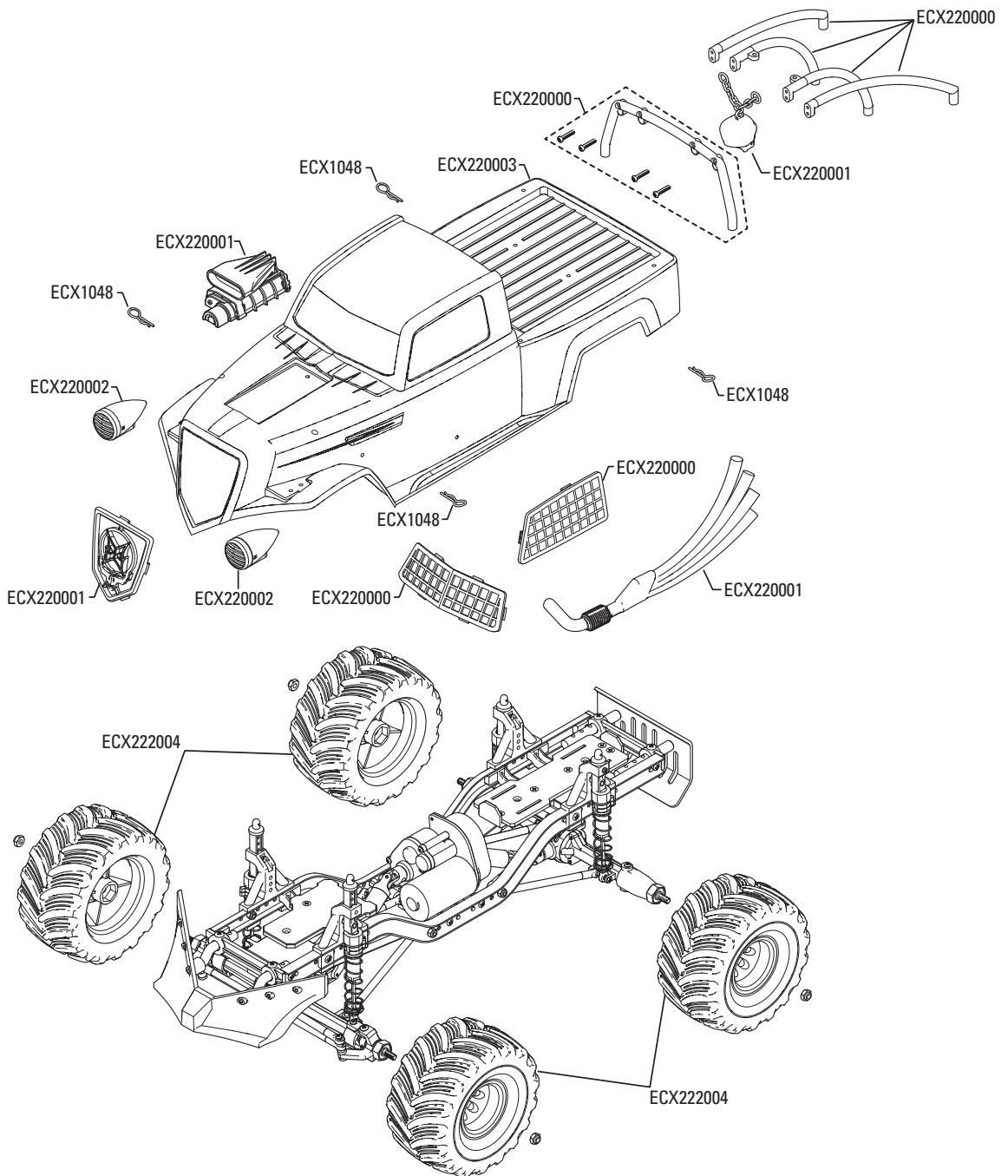

ECX216003 – Complete hardware set | Kompletter Schrauben-Set | Set de visserie complet | Set completo viti  
 ECX217001 – Bearing set | Kugellager-set | Set de roulement | Set di cuscinetti



**PARTS DIAGRAM | EXPLOSIONSZEICHNUNG | VUE ÉCLATÉE DES PIÈCES |  
ESPLOSO DEL MODELLO CON REFERENZA PEZZI**

**FRONT AXLE | VORDERACHSE | HINTERACHSE | ASSE ANTERIORE**

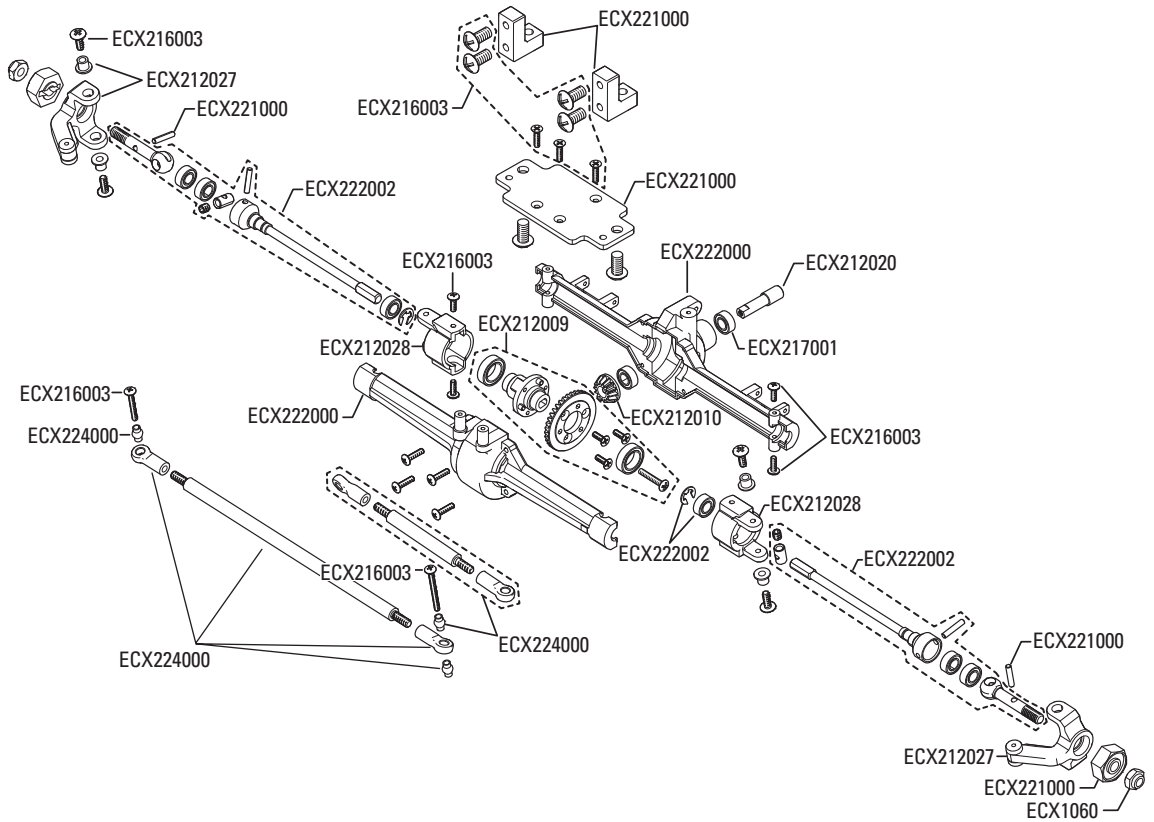



# PARTS DIAGRAM | EXPLOSIONSZEICHNUNG | VUE ÉCLATÉE DES PIÈCES | ESPLOSO DEL MODELLO CON REFERENZA PEZZI

REAR AXLE | ESSIEU AVANT | ESSIEU ARRIÈRE | ASSE POSTERIORE

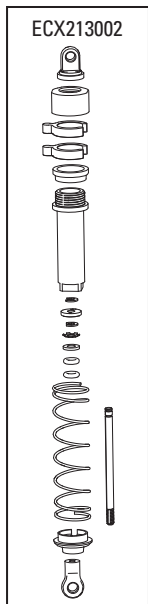
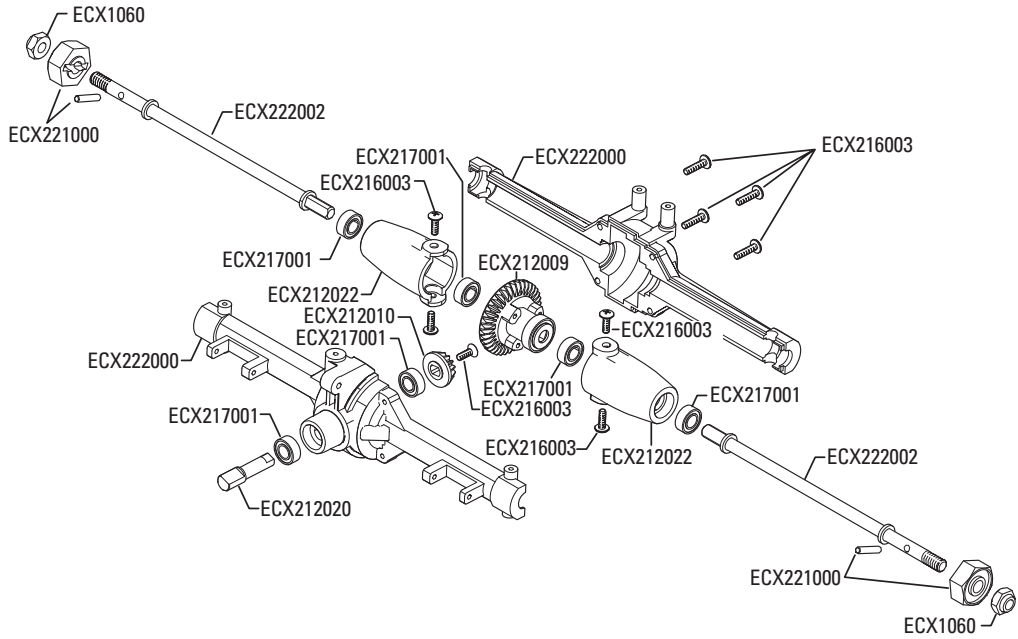

**PARTS DIAGRAM | EXPLOSIONSZEICHNUNG | VUE ÉCLATÉE DES PIÈCES |  
ESPLOSO DEL MODELLO CON REFERENZA PEZZI**

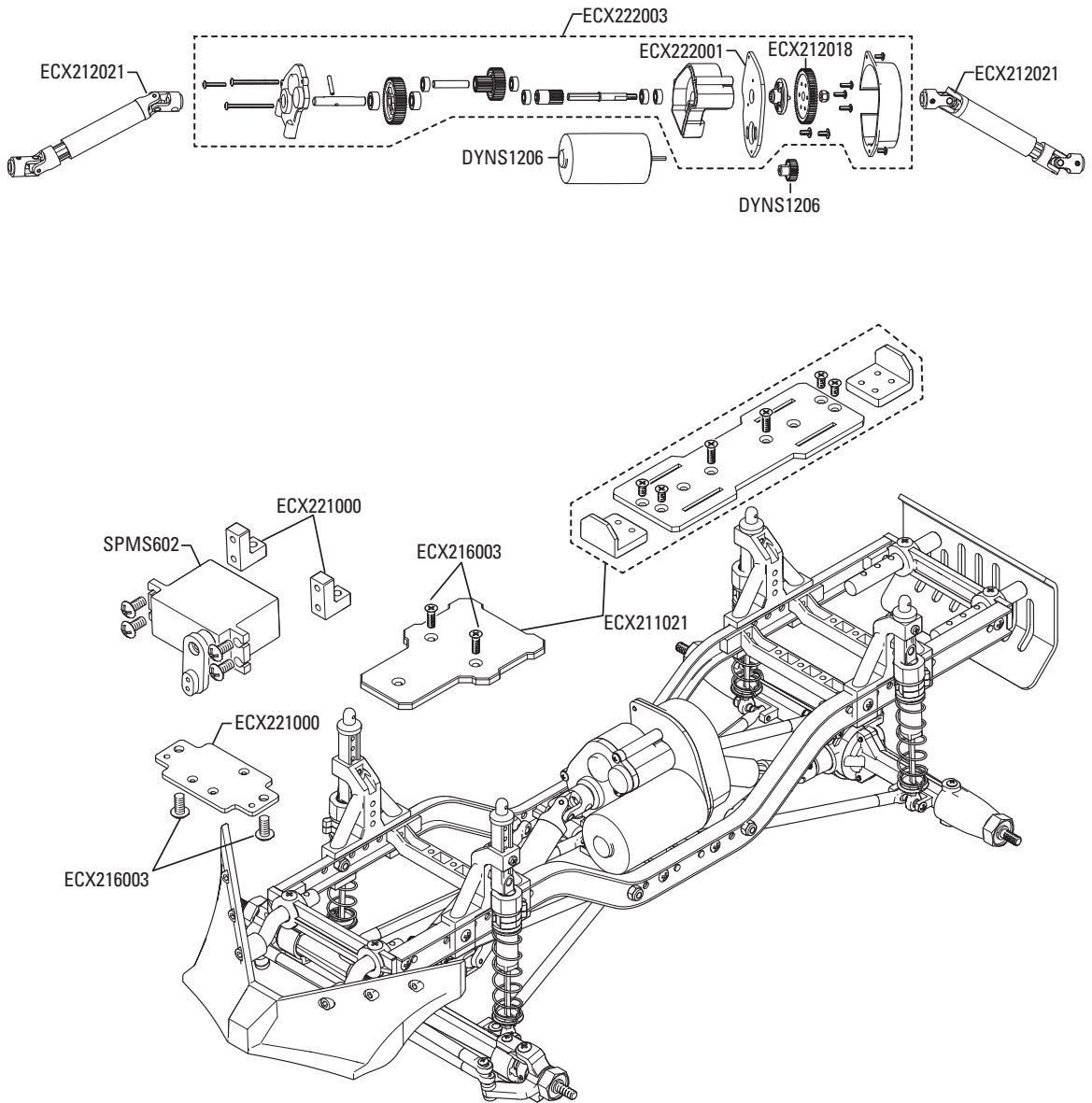





**ECX01010**  
**[www.ecxrc.com](http://www.ecxrc.com)**

© 2017 Horizon Hobby, LLC. ECX, the ECX logo, Barrage Doomsday, Dynamite, Speedpack, Prophet, Tazer, EC3, and the Horizon Hobby logo are trademarks or registered trademarks of Horizon Hobby, LLC. The Spektrum trademark is used with permission of Bachmann Industries, Inc. Created 06/2017

52320