

Carbon-Z™ Splendor™

Instruction Manual - Bedienungsanleitung - Manuel d'utilisation - Manuale di Istruzioni



BNF
BASIC

CARBON  STRUCTURE

E-flite
ADVANCING ELECTRIC FLIGHT

NOTICE

All instructions, warranties and other collateral documents are subject to change at the sole discretion of Horizon Hobby, Inc. For up-to-date product literature, visit www.horizonhobby.com and click on the support tab for this product.

Meaning of Special Language:

The following terms are used throughout the product literature to indicate various levels of potential harm when operating this product:

NOTICE: Procedures, which if not properly followed, create a possibility of physical property damage AND little or no possibility of injury.

CAUTION: Procedures, which if not properly followed, create the probability of physical property damage AND a possibility of serious injury.

WARNING: Procedures, which if not properly followed, create the probability of property damage, collateral damage, and serious injury OR create a high probability of superficial injury.



WARNING: Read the ENTIRE instruction manual to become familiar with the features of the product before operating. Failure to operate the product correctly can result in damage to the product, personal property and cause serious injury.

This is a sophisticated hobby product. It must be operated with caution and common sense and requires some basic mechanical ability. Failure to operate this Product in a safe and responsible manner could result in injury or damage to the product or other property. This product is not intended for use by children without direct adult supervision. Do not use with incompatible components or augment product in any way without the approval of Horizon Hobby, Inc. This manual contains instructions for safety, operation and maintenance. It is essential to read and follow all the instructions and warnings in the manual, prior to assembly, setup or use, in order to operate correctly and avoid damage or serious injury.

Age Recommendation: Not for children under 14 years. This is not a toy.

Safety Precautions and Warnings

As the user of this product, you are solely responsible for operating in a manner that does not endanger yourself and others or result in damage to the product or the property of others.

- Always keep a safe distance in all directions around your model to avoid collisions or injury. This model is controlled by a radio signal subject to interference from many sources outside your control. Interference can cause momentary loss of control
- Always operate your model in open spaces away from full-size vehicles, traffic and people.
- Always carefully follow the directions and warnings for this and any optional support equipment (chargers, rechargeable battery packs, etc.).
- Always keep all chemicals, small parts and anything electrical out of the reach of children.
- Always avoid water exposure to all equipment not specifically designed and protected for this purpose. Moisture causes damage to electronics.
- Never place any portion of the model in your mouth as it could cause serious injury or even death.
- Never operate your model with low transmitter batteries.
- Always keep aircraft in sight and under control.
- Always use fully charged batteries.
- Always keep transmitter powered on while aircraft is powered.
- Always remove batteries before disassembly.
- Always keep moving parts clean.
- Always keep parts dry.
- Always let parts cool after use before touching.
- Always remove batteries after use.
- Always ensure failsafe is properly set before flying.
- Never operate aircraft with damaged wiring.
- Never touch moving parts.

Introduction

Welcome to the cutting edge of electric flight! World Aerobatic Champion, Quique Somenzini, designed your new E-flite® Carbon-Z™ Splendor™ aircraft to deliver everything the world of precision flying has to offer. Beautiful from any angle you look at it, the Carbon-Z Splendor allows you to perform both elegant F3A aerobatic maneuvers and extreme 3D stunts all in the same flight. In conjunction with rigid Carbon-Z construction, the remarkable AS3X® technology built into the included Spektrum™ AR635 receiver makes it possible for you to experience a performance envelope that's wider than ever before possible. This means that no matter how you like to fly, you'll enjoy both

rock-solid stability and outrageous maneuverability without any sacrifice in precision or control feel. Other outstanding highlights include a custom-designed power system and high-quality E-flite digital servos. Your Splendor aircraft represents the benchmark of performance and aerobatic versatility. And it's brought to you with the convenience and value of Bind-N-Fly® Basic technology. All you have to do next is read and apply the information presented in this instruction manual, then choose your favorite Li-Po flight battery and DSM2®/DSMX® compatible transmitter.

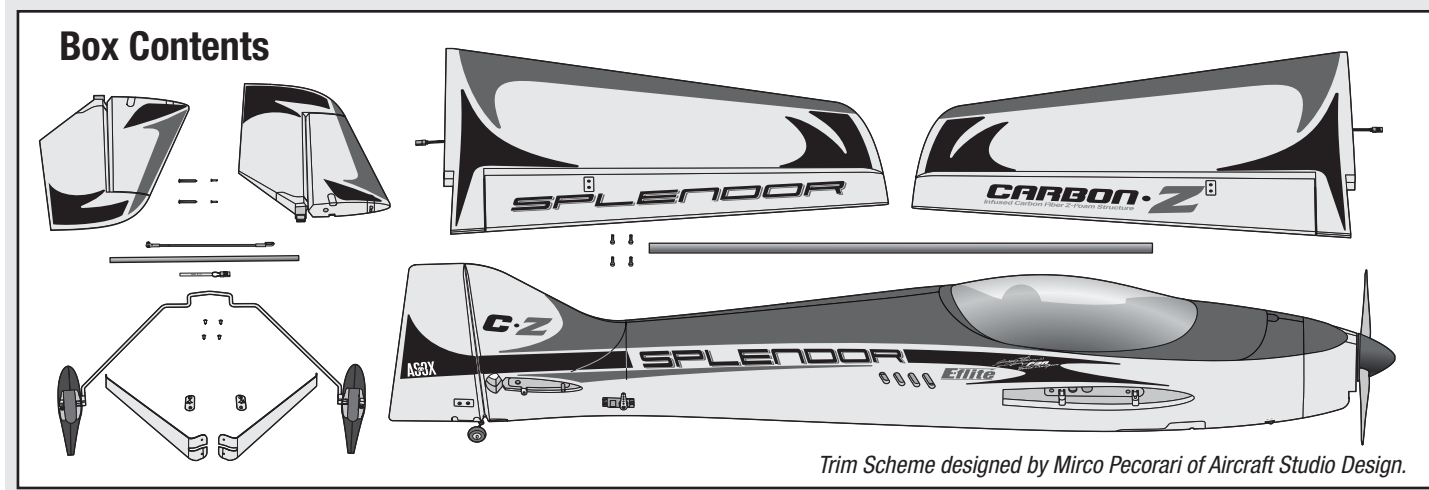







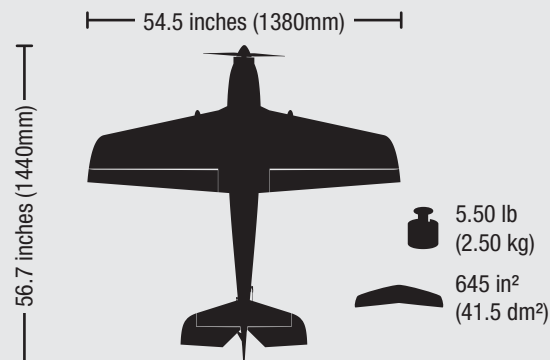

Table of Contents

- Specifications 3
- Transmitter and Receiver Binding..... 4
- Installing the Battery 5
- Low Voltage Cutoff (LVC) 5
- AS3X System 5
- Arming the ESC and Receiver..... 6
- Installing Landing Gear 6
- Installing the Horizontal Tail..... 7
- Factory Servo Arm Settings..... 7
- Installing the Wings 8
- Center of Gravity (CG) 8
- AS3X Control Direction Test 9
- Control Direction Test 9
- Control Surface Centering, Transmitter and Receiver Operation 9
- Transmitter Setup 10
- Dual Rates and Expos 10
- Preflight Checklist..... 11
- Flying Tips and Repairs 11
- Maintenance After Flying 11
- Guidelines for Precision Flying 12
- Service of Power Components 13
- AMA National Model Aircraft Safety Code..... 14
- Federal Aviation Administration 14
- Troubleshooting Guide AS3X 15
- Troubleshooting Guide 16
- Limited Warranty 17
- Contact Information 18
- Parts Contact Information 67
- Replacement Parts..... 67
- Optional Parts 68
- Flight Log 69

Specifications

	BL50 Brushless Outrunner Motor, 525Kv	Installed
	60-Amp Pro Switch-Mode BEC Brushless ESC (V2)	Installed
	(4) 26 g Digital MG Mini Servo (EFLR7145)	Installed
	Spektrum™ AR635, 6-Channel AS3X Sport Receiver	Installed
	Battery: 3200mAh 22.2V 6S 30C Li-Po (EFLB32006S30)	Needed to Complete
	Battery Charger: 6-cell Li-Po battery balancing charger	Needed to Complete
	Recommended Transmitter: Full-Range 2.4GHz with Spektrum DSM2/DSMX technology with adjustable Expo and Dual rate.	Needed to Complete





Transmitter and Receiver Binding

Binding is the process of programming the receiver to recognize the GUID (Globally Unique Identifier) code of a single specific transmitter. You need to 'bind' your chosen Spektrum™ DSM2®/DSMX® technology equipped aircraft transmitter to the receiver for proper operation.

Please visit www.bindnfly.com for a complete list of compatible transmitters.

CAUTION: When using a Futaba® transmitter with a Spektrum DSM module, you must reverse the throttle channel and rebind. Refer to your Spektrum module manual for binding and failsafe instructions. Refer to your Futaba transmitter manual for instructions on reversing the throttle channel.

✓ Binding Procedure Reference Table

Read the transmitter instructions for binding to a receiver (location of transmitter's Bind control).	
1.	Make sure the transmitter is powered off.
2.	Move the transmitter controls to neutral (flight controls: rudder, elevators and ailerons) or to low positions (throttle, throttle trim).**
3.	Install a bind plug in the receiver bind port.
4.	Connect the flight battery to the ESC, then power on the ESC switch. The ESC will produce a series of sounds. One long tone, then 6 short tones confirm that the LVC is set correctly for the ESC. The orange bind LED on the receiver will begin to flash rapidly.
5.	Power on the transmitter while holding the transmitter bind button or switch. Refer to your transmitter's manual for binding button or switch instructions.
6.	When the receiver binds to the transmitter, the orange bind light on the receiver will turn solid and the ESC will produce a series of three ascending tones. The tones indicate the ESC is armed, provided the throttle stick and throttle trim are low enough to trigger arming.
7.	After binding, the 3 LEDs (blue, yellow and red) on the receiver will flash. The flashing indicates the gain setting for each axis. The quicker the flash, the higher the gain setting. For more information, refer to the "Initializing the AR635" section in the receiver manual.
8.	Remove the bind plug from the bind port.
9.	Safely store the bind plug (some owners attach the bind plug to their transmitter using two-part loops and clips).
10.	The receiver should retain the binding instructions received from the transmitter until another binding is done.

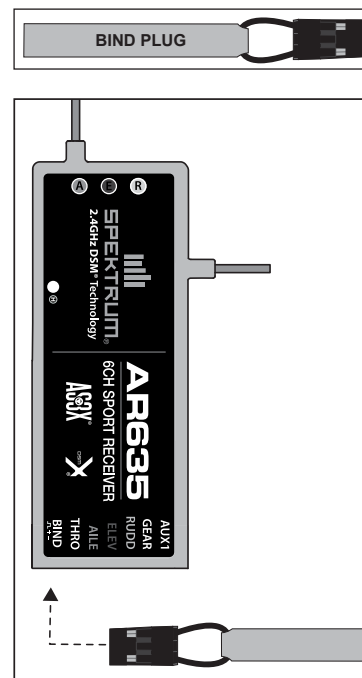

** The throttle will not arm if the transmitter's throttle control is not put at the lowest position. If you encounter problems, follow the binding instructions and refer to the transmitter Troubleshooting Guide for other instructions. If needed, contact the appropriate Horizon Product Support office.

Installing the Battery

1. Press the latch button (A) to lift the front edge of the canopy hatch, then pull the hatch up and forward from the fuselage.
2. Apply the included strip of hook and loop tape to the bottom of your battery(s).
3. For the recommended CG, install the battery(s) all the way to the back of the compartment, then press the battery(s) onto the hook and loop strip (B). Close the 2 hook and loop straps (C) around the battery(s). See the Adjusting the Center of Gravity instructions for more information.
4. Connect a fully charged battery(s) to the ESC. See the *Arming the ESC instructions for correct connection of the battery to the ESC*.
5. Reinstall the canopy hatch.

CAUTION: Always disconnect the Li-Po battery from the aircraft receiver when not flying to avoid over-discharging the battery. Batteries discharged to a voltage lower than the lowest approved voltage may become damaged, resulting in loss of performance and potential fire when batteries are charged.

CAUTION: Always keep hands away from the propeller. When armed, the motor will turn the propeller in response to any throttle movement.

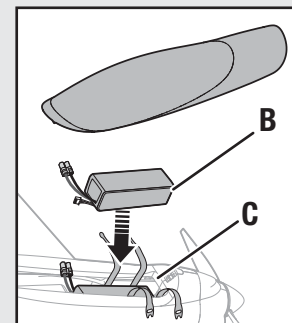
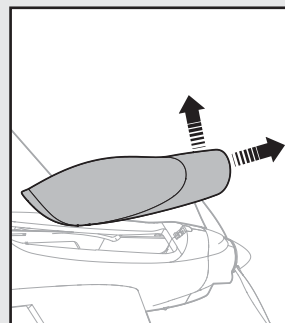
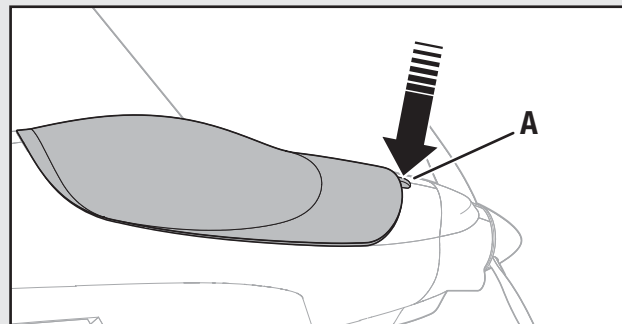

Dual Battery Setup

An optional Y-harness (EFLAEC308) is included to connect (2) 3S Li-Po batteries (EFLB32003S30, sold separately) in series to the ESC instead of (1) 6S Li-Po battery (sold separately). If (2) 3S Li-Po batteries are used, join them in a stack using hook and loop strips. Secure the battery stack in place using the instructions described in steps 2 and 3 above.

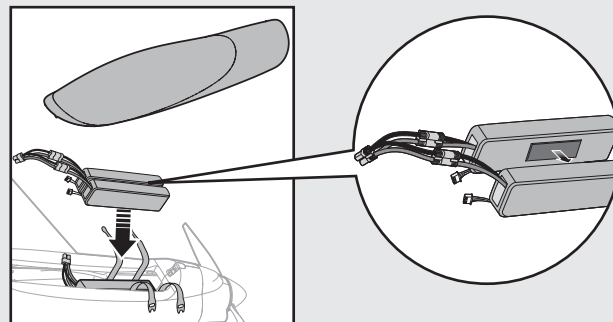

Low Voltage Cutoff (LVC)

When a Li-Po battery is discharged below 3V per cell, it will not hold a charge. The ESC protects the flight battery from over-discharge using Low Voltage Cutoff (LVC). Before the battery charge decreases too much, LVC removes power supplied to the motor. Power to the motor pulses, showing that some battery power is reserved for flight control and safe landing. When the motor

pulses, land the aircraft immediately and recharge the flight battery. Disconnect and remove the Li-Po battery from the aircraft after use to prevent trickle discharge. Charge your Li-Po battery to about half capacity before storage. During storage, make sure the battery charge does not fall below 3V per cell.

AS3X System

Horizon Hobby has always made RC sport, scale and unique aircraft with the kind of performance experts appreciate. First used in Blade® ultra micro flybarless helicopters, MEMS sensor technology within the Artificial Stability--3 axis (AS3X) System has been specifically tuned for airplanes helping invisibly correct for turbulence, torque and tip stalls.

Now the exclusive AS3X Stabilization system makes the leap from Ultra Micro aircraft to high performance parkflyers with the AR635 receiver. The precision and performance available from AS3X equipped Ultra Micro airplanes

has heralded a new era of performance, and with the AR635, that performance is introduced for larger airplanes.

The outstanding control agility delivers an ultra smooth, locked-in feel that obeys your every command with performance that's natural feeling. It's so gratifying, in fact, that it's as though you're the RC pilot of an expertly tuned, giant-scale aircraft. Welcome to AS3X, your parkflyer will never be the same! To see what we mean, go to www.E-fliteRC.com/AS3X.

Arming the ESC and Receiver

Arming the ESC also occurs after binding as previously described, but subsequent connection of a flight battery requires the steps below.

AS3X

The AS3X system will not activate until the throttle stick or trim is increased for the first time. Once the AS3X is active, the control surfaces may move rapidly on the aircraft. This is normal. AS3X will remain active until the battery is disconnected.

NOTICE: Due to increased servo power demands, only use the 60-Amp Pro Switch-Mode BEC Brushless ESC (EFA1060B V2) with the AR635 receiver. Use of any other ESC presently available may result in damage to the aircraft.

DO NOT connect the battery while the throttle stick is at full or the ESC will go into programming mode. If a musical tone sounds after 5 seconds, immediately disconnect the battery, then lower the throttle. Refer to the ESC manual (available separately) for more information.

1. Lower the throttle and throttle trim to lowest settings. Power on the Transmitter, then wait 5 seconds.
2. Remove the battery hatch and install the flight battery to the hook and loop strip, then connect the battery to the ESC, noting proper polarity.
3. Power on the ESC switch on the right side of the aircraft. Keep the aircraft immobile on its wheels away from wind for 5 seconds.
 - The ESC will sound a series of tones (refer to step 4 of the binding instructions for more information).
 - An LED will light on the receiver (the red, blue and green gain LEDs will also flash).

If the ESC sounds a continuous double beep after the flight battery is connected, recharge or replace the battery.

For further explanation of the gain lights, refer to the "Initializing the AR635" section of the AR635 receiver manual.

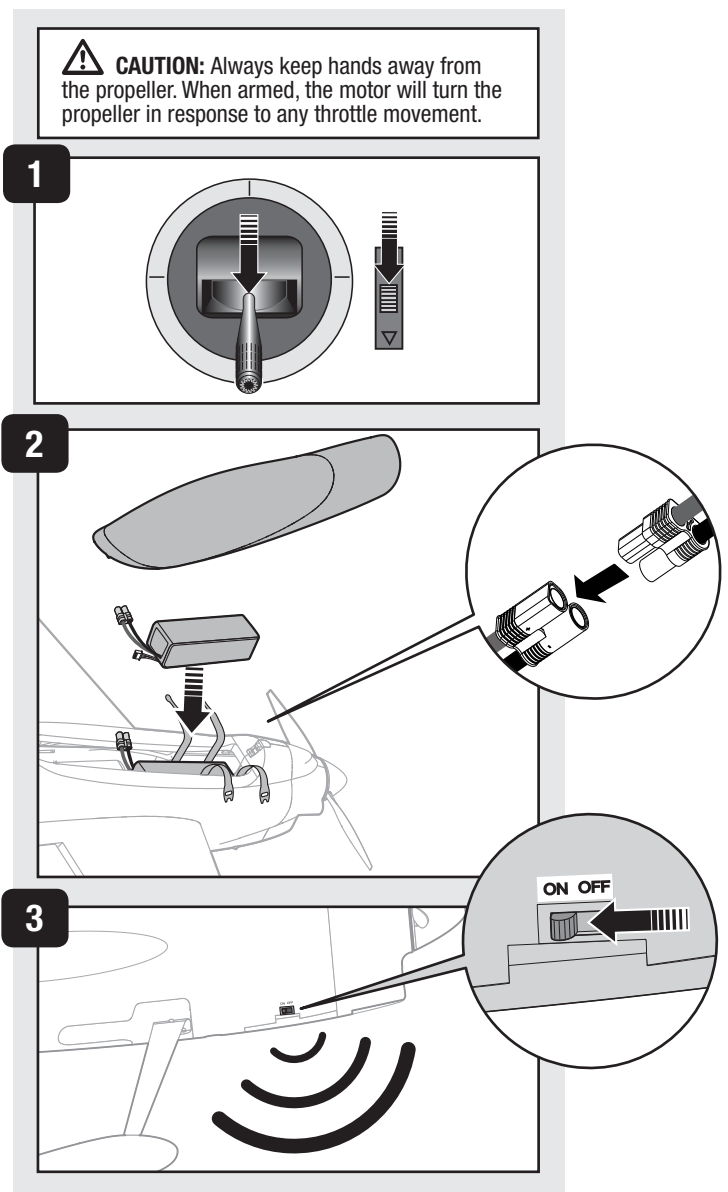

TIP

The ESC switch enables you to easily disarm the propeller while you are not flying, but will still draw current from the battery.

Installing Landing Gear

1. Install the landing gear (A) with the wheel pants pointed to the rear as shown.
2. Install the covers (B) and fairings (C) on the landing gear strut and fuselage using 4 screws (D).
3. When needed, disassemble in reverse order.



TIP

Carefully support the aircraft while installing or removing screws.

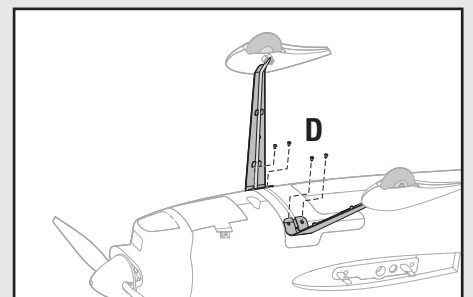
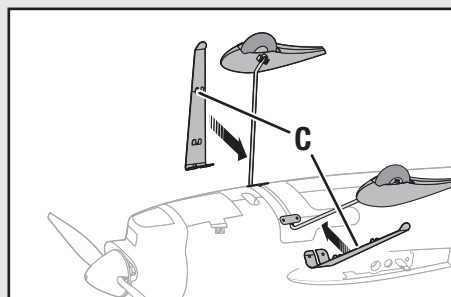
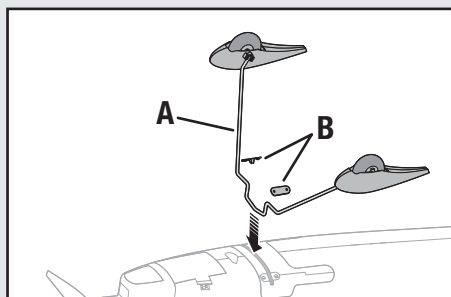

Installing the Horizontal Tail

1. Slide the horizontal tail tube (A) into the hole in the rear of the fuselage.
2. Install the 2 piece (left and right) horizontal tail as shown.
3. Install 2 short screws in the forward holes in the horizontal tail.
4. Install 2 long screws in the rear holes in the horizontal tail.
5. Attach the linkage between the servo arm and the control horn on the elevator using the included ball link (B), nut (C), screw (D) and link cover (E). Ensure the servo arms are in the correct positions, then adjust the linkages to center the control surfaces.
6. When needed, disassemble in reverse order.

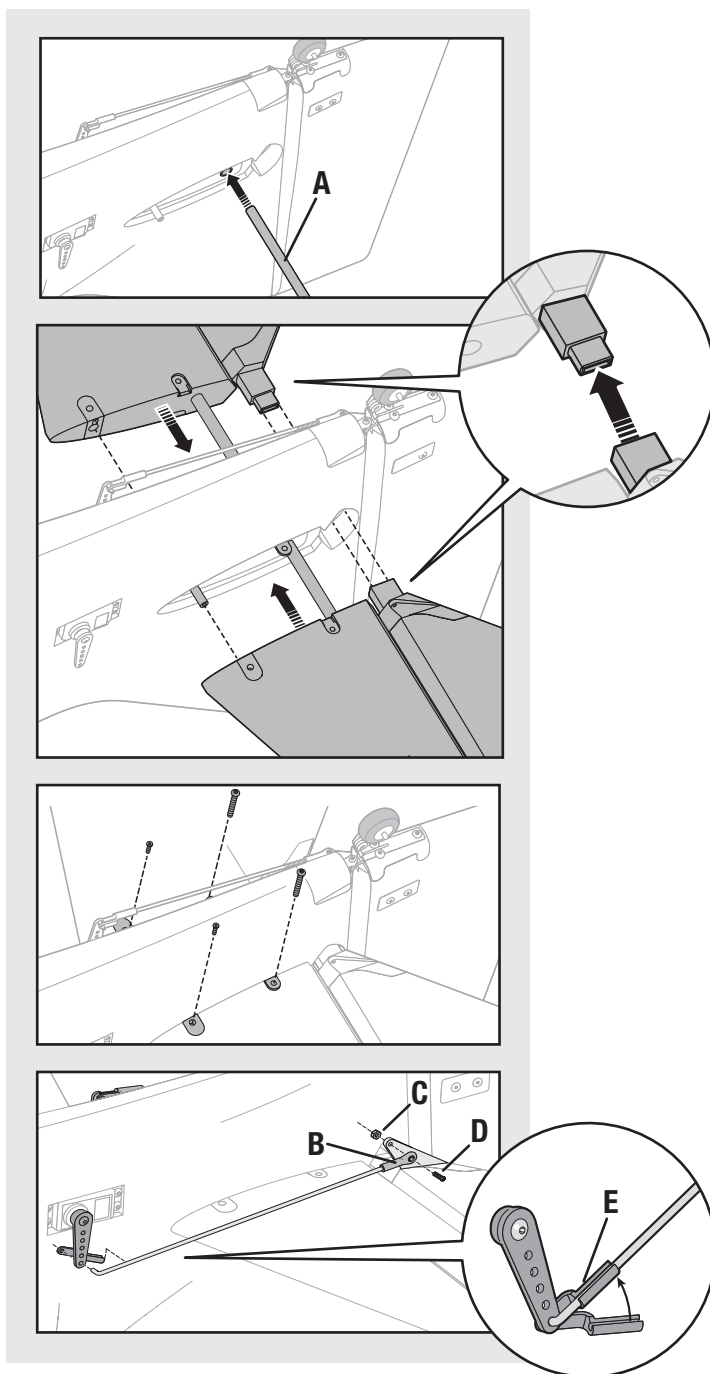

Factory Servo Arm Settings

Fly the model at recommended settings before making changes. The linkages installed at the factory position are chosen for the most balanced aerobatic response and AS3X performance. Linkage connections directly affect aircraft response and AS3X performance.

NOTICE: Moving a linkage to another position may block the servo arm or require the gain to be adjusted.

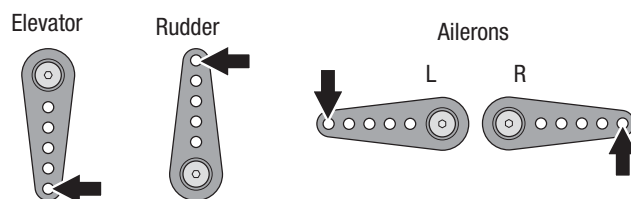

Installing the Wings

1. Remove the canopy hatch before installing the wings.
2. Slide the wing tube (A) into the fuselage.
3. Install the left and right wing (B and C) over the wing tube and into the wing slot of the fuselage while inserting the aileron servo connectors through the provided holes.

CAUTION: DO NOT crush or otherwise damage the wiring when attaching the wing to the fuselage.

4. Invert the fuselage so the landing gear is facing up. Secure the left and right wings to the fuselage using the 4 included screws (D).
5. Connect the aileron servos from the wings to the Y-harness connectors in the fuselage. The left and right aileron servos can be connected to either side of the Y-harness.
6. Replace the canopy hatch on the fuselage. Engage the latch so that the front edge of the canopy is flush with the fuselage.

Disassemble in reverse order.

IMPORTANT: Correct operation of the AS3X system requires connection of both ailerons to the included Y-harness and the AILE channel of the receiver.

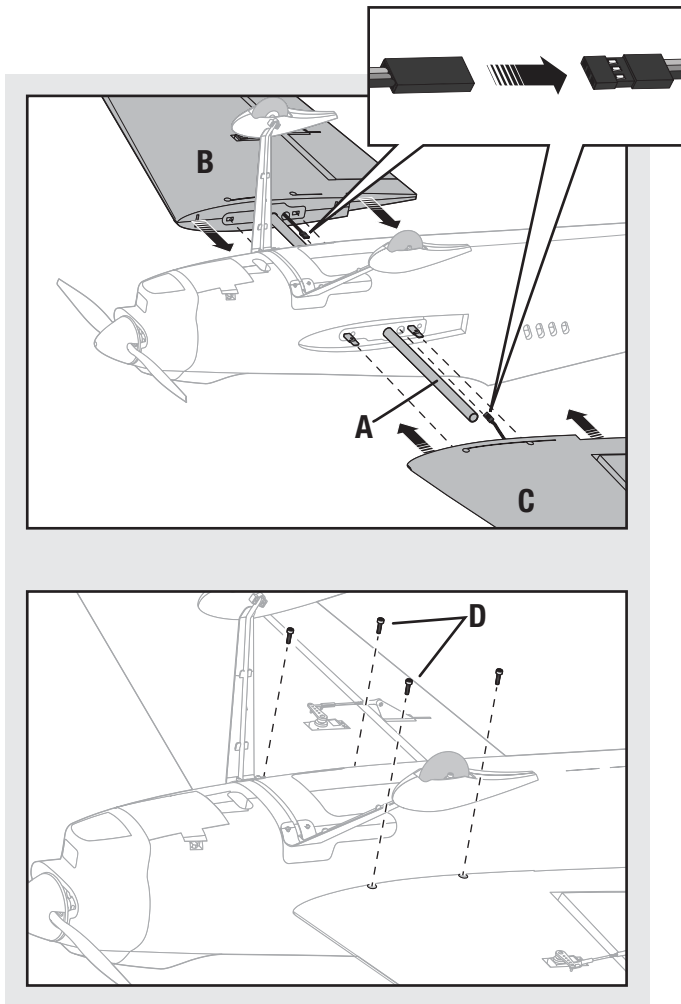

TIP

If needed, use hemostats or pliers to pull the servo connectors into the fuselage.

Center of Gravity (CG)

The CG location is measured from the leading edge of the wing at the root. This CG location has been determined with the recommended Li-Po battery installed near the rear of the battery compartment.

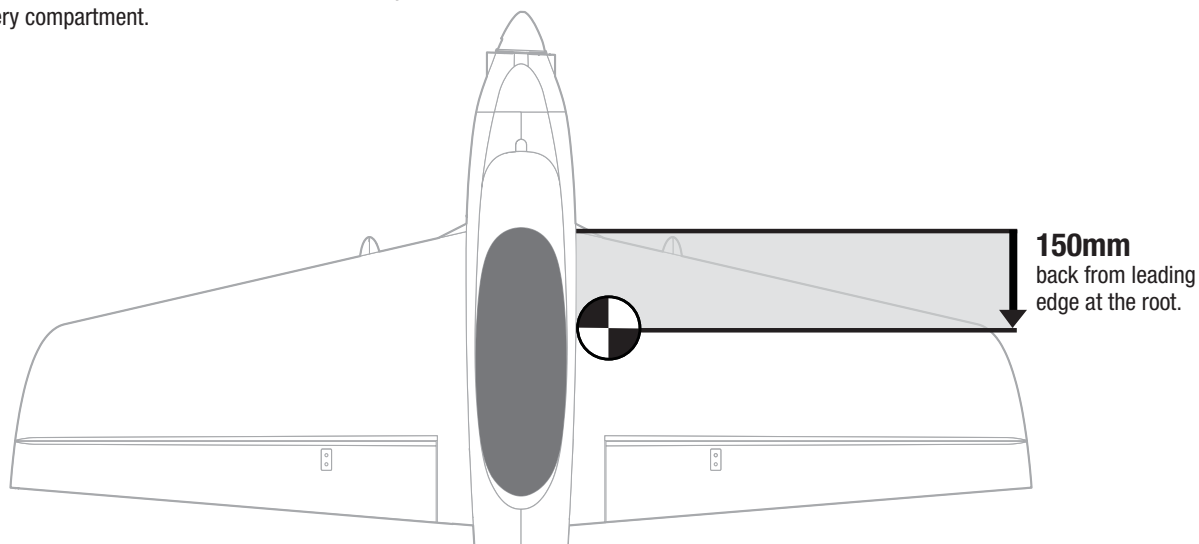







AS3X Control Direction Test

Assemble the aircraft and bind your transmitter to the receiver before performing this Test.

Activate the AS3X system by advancing the throttle to 25%, then fully lowering the throttle.

Move the aircraft as shown to ensure the AS3X system moves the control surfaces in their proper direction. If the control surfaces do not respond as shown, do not fly the aircraft. Refer to the receiver manual for more information.

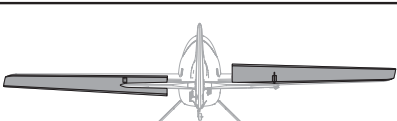
Once the AS3X system is active, the control surfaces may move rapidly on the aircraft. This is normal. AS3X will remain active until the battery is disconnected.

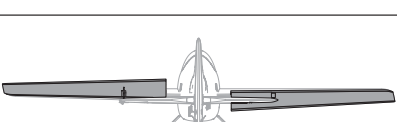
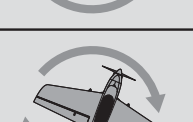
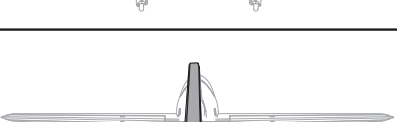
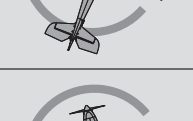
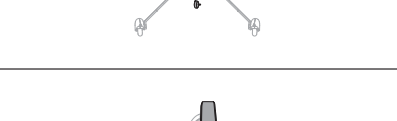
	Aircraft movement	AS3X Reaction
Elevator		
		
Aileron		
		
Rudder		
		

Control Direction Test

Move the controls on the transmitter to make sure the aircraft control surfaces move correctly and in the proper direction or reverse a servo. After performing the Control Test, correctly set the failsafe. Make sure the transmitter controls are at neutral and the throttle and throttle trim are in the low position, then rebind the model to your transmitter. If the receiver loses its connection to the transmitter, the failsafe will drive the servos to the settings made at binding.

NOTICE: In your transmitter, ensure Channel 5 servo is in NORMAL position for proper AS3X functionality.

Control Surface Centering, Transmitter and Receiver Operation

IMPORTANT: Perform the Control Direction Test before performing control surface centering.

Control Surface Centering and Adjusting a Linkage

Tip: While AS3X is inactive (before advancing the throttle), mechanically center the control surfaces.

IMPORTANT: Correct operation of the AS3X system requires sub-trim and trim at 0.

After binding a transmitter to the model receiver, set the trims and sub-trims to 0, ensure the servo arms are in the correct positions, then adjust the linkages to center the control surfaces.

- Turn the linkage clockwise or counter-clockwise until the control surface is centered.
- Attach the linkage to the servo arm or control horn after adjustment.

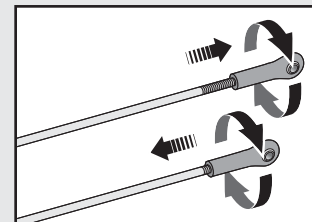

Tip: If using more than 8 clicks of flight trim, mechanically adjust the linkage so less trim is needed, or AS3X operation may be affected.

Tip: Use needle-nose pliers or ball link pliers (RV01005) to remove or install a link on a control horn.

Transmitter Setup

IMPORTANT: The AR635 receiver's default setting is Computerized Transmitter 3D. We recommend that you do not change this setup. Refer to the receiver manual for more information.

A DSM2/DSMX five-channel (or better) transmitter with adjustable Dual Rates and adjustable exponential is required for flying this aircraft. The *Spektrum™* DX6i, DX7s, DX8, DX10t, DX18 and JR® X9503, 11X or 12X transmitters may be used.

The settings below are Quique's recommended settings.

Servo Travel

Throttle	100%
Aileron	125%
Elevator	125%
Rudder	125%
Channel 5	100%

Tip: If desired, the recommended transmitters can activate all 3-channel Dual Rates (aileron, rudder, elevator) using a combined Dual Rate switch. This can decrease the pilot's work load. Adjust rate and expo to the recommended values shown in the chart below.

Dual Rates and Expos

F3A Mode (Channel 5, position 0)

Use low rates for general flying, snap rolls and point rolls.
Use high rates for stall turns, rolling circles, rolling loops and spins.

Dual Rate	High Rate	Expo	Low Rate	Expo
Aileron	100%	15%	80%	15%
Elevator	100%	15%	75%	15%
Rudder	100%	20%	60%	10%

3D Mode (Channel 5, position 1)

Use low rates for mild 3D.
Use high rates for extreme 3D.

Dual Rate	High Rate	Expo	Low Rate	Expo
Aileron	100%	15%	80%	15%
Elevator	100%	15%	75%	15%
Rudder	100%	20%	60%	10%

NOTICE: To ensure AS3X functions properly, do not lower rate values below 50%. If lower rates are desired, manually adjust the position of the pushrods on the servo arm.

✓ Transmitter Setup Checklist

Before binding for Computerized Transmitters (DX6i, DX7/DX7se, DX7s, DX8, DX10t, DX18):

1. Choose a blank model memory with only default (zero) settings (including trim and sub-trim).
2. Choose Wing/Aircraft Type for single aileron servo.
3. Set all sub-trims to NEUTRAL (0%).
4. Set servo travel values to 125% for Aileron, Elevator, and Rudder.
5. Set the Dual Rate value according to the Dual Rate and Expo chart.

After binding:

1. Check and adjust the servos so each arm's neutral position is perpendicular or as close to 90° as possible (loosen and adjust the servo arm splines on the servo only when needed). **DO NOT** use sub-trims to make fine adjustments. Off-center sub-trim will affect servo travel and AS3X operation.
2. Adjust linkage lengths so the control surfaces center when the servo arm is close to perpendicular.



CAUTION: For safe operation, always re-bind the airplane after setup is complete to ensure the failsafe is updated with the latest setup.



CAUTION: When flying above 50% of the top air speed in level flight, only use F3A mode. Flying at these speeds in 3D mode will result in strong oscillations that could damage the aircraft. Use care when switching between F3A and 3D modes.

Preflight Checklist

1. Remove and inspect contents.
2. Charge flight battery.
3. Read this instruction manual thoroughly.
4. Fully assemble model.
5. Install the flight battery in the aircraft (once it has been fully charged).
6. Check the Center of Gravity (CG)
7. Bind aircraft to your transmitter.
8. Make sure linkages move freely.
9. Perform the AS3X Control Direction Test with the aircraft.
10. Perform the Control Direction Test with the transmitter.
11. Adjust flight controls and transmitter.
12. Perform a radio system Range Check.
13. Find a safe and open area.
14. Plan flight for flying field conditions.

Flying Tips and Repairs

Flying Field

Always choose a wide-open space for flying your aircraft. It is ideal for you to fly at a sanctioned flying field. If you are not flying at an approved site, always avoid flying near houses, trees, wires and buildings. You should also be careful to avoid flying in areas where there are many people, such as busy parks, schoolyards, or soccer fields. Consult local laws and ordinances before choosing a location to fly your aircraft.

Range Check your Radio System

Before you fly, range check the radio system. Refer to your specific transmitter instruction manual for range test information.

Understanding Oscillation

Once the AS3X system is active (after advancing the throttle for the first time), you will see the control surfaces react to aircraft movement. In some flight conditions, you will see oscillation. If oscillation occurs, decrease the airspeed. If oscillation continues, ensure the aircraft is in F3A mode for higher airspeeds. If oscillation still persists, refer to the Troubleshooting Guide for more information.

Takeoff

Place the aircraft in position for takeoff (facing into the wind). Set the flight mode to F3A (Channel 5, position 0) and gradually increase the throttle to 3/4 to full and steer with the rudder. Pull back gently on the elevator and climb to a comfortable altitude.

Flying

Before activating 3D mode, fly the airplane and trim it for level flight at full throttle. After landing, adjust the linkages mechanically to account for trim changes, then reset the trims to neutral. Before changing flight modes, ensure the aircraft will fly straight and level with no trim or sub-trim.

This aircraft is extremely responsive to control input. Fly in F3A mode (Channel 5, position 0) until you are familiar with the aircraft's response. Fly first attempts in 3D mode at high altitude and slow speeds.

F3A and 3D flight

The receiver's default gain settings for F3A and 3D modes are set at the factory for safe and reliable performance.

CAUTION: Flying in level forward flight and calm wind conditions above 1/2 throttle in 3D mode or long high-speed dives may result in strong oscillation that can damage the aircraft.

If there is oscillation in either mode (F3A or 3D), decrease throttle immediately. If oscillation persists, refer to the Troubleshooting Guide to adjust (decrease) the axis gain to stop oscillation. For additional instructions on changing the gain settings, refer to the receiver manual.

Landing

For your first flights and with the recommended battery pack, set your transmitter timer or a stopwatch to 6 minutes.

Adjust your timer for longer or shorter flights once you have flown the model. When the motor pulses, land the aircraft immediately and recharge the flight battery. It is not recommended to fly the battery to LVC.

Make sure to land into the wind. Fly the aircraft to approximately 36 inches (90 cm) or less above the runway, using a small amount of throttle for the entire descent. Keep the throttle on until the aircraft is ready to flare. During flare, keep the wings level and the aircraft pointed into the wind. Gently lower the throttle while pulling back on the elevator to bring the aircraft down on its wheels.

NOTICE: If a crash is imminent, reduce the throttle and trim fully. Failure to do so could result in extra damage to the airframe, as well as damage to the ESC and motor.

Crash damage is not covered under warranty.

NOTICE: When you are finished flying, never keep the airplane in the sun. Do not store the aircraft in a hot, enclosed area such as a car. Doing so can damage the foam.

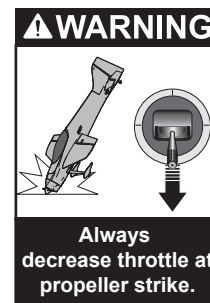

Repairs

Thanks to the Z-Foam™ material in this aircraft, repairs to the foam can be made using virtually any adhesive (hot glue, regular CA, epoxy, etc). When parts are not repairable, see the Replacement Parts List for ordering by item number. For a listing of all replacement and optional parts, refer to the list at the end of this manual.

NOTICE: Use of CA accelerant on your aircraft can damage paint. DO NOT handle the aircraft until accelerant fully dries.

Maintenance After Flying

1. Disconnect flight battery from ESC (Required for Safety and battery life).
2. Power off transmitter.
3. Remove flight battery from aircraft.
4. Recharge flight battery.
5. Repair or replace all damaged parts.
6. Store flight battery apart from aircraft and monitor the battery charge.
7. Make note of flight conditions and flight plan results, planning for future flights.

Guidelines for Precision Flying

The E-flite Splendor aircraft and its AS3X system were designed together to help an intermediate pilot apply standard flying skills to precision flying. This aircraft excels in precision maneuvers. While the AS3X system is activated, you can practice precision maneuvers in more wind or tougher conditions. This system gives this aircraft the feel of a bigger aircraft, similar to a 2-meter F3A competition aircraft.

Switch between F3A and 3D options, while in flight, using the assigned channel 5/AUX switch on your transmitter:

- Use the F3A option for high speed, precision maneuvers
- Use the 3D option for low speed, controlled flying-beyond-the-stall maneuvers

Building Your Skills

Increasing your skills takes time. Practice regularly and try following a plan for increasing your skills. Mastering one maneuver at a time may be more beneficial than trying to learn everything all at once. Always stay aware of your aircraft's performance in different conditions and attitudes:

What response can you consistently get from your aircraft?

- *Set up your aircraft for consistent response in all attitudes and flight conditions where you choose to fly. Not all challenges are due to the equipment, just as not all challenges are due to the pilot's skills.*
- *If you feel you reach a plateau in your skills, see if you have built the right habits in the fundamentals of precision flying. Play to your strengths and the strengths of your aircraft while minimizing reliance on areas of weakness.*
- *Know yourself and your equipment well enough so you can confidently take on greater challenges.*
- *Push yourself, but avoid pushing past your aircraft's performance envelope.*
- *Seek fun ways to safely share your enjoyment of precision flying.*

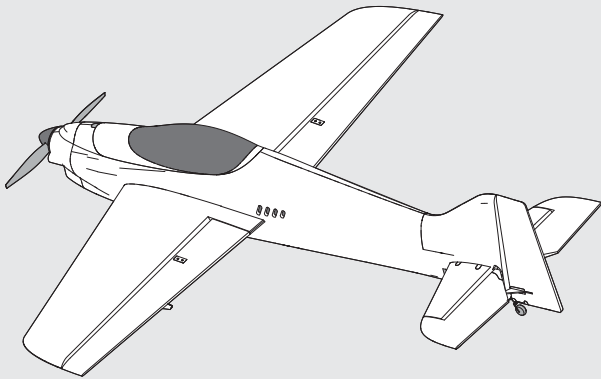

If you compete under national (AMA) or international rules (FAI), turn all gains to zero to deactivate the AS3X system (refer to the receiver manual). Competition rules do not allow the use of gyros or a stabilization system.

Visit www.fai.org, www.modelaircraft.org or www.mini-iac.com for current radio-controlled aerobatic competition rules. If desired, search for "Known" patterns, published annually for competitors to practice.

F3A Maneuvers

Lines:	For your first attempts, fly on an imaginary line perpendicular to a line directly in front of you. Strive to enter and exit maneuvers in straight and level flight.
Loops:	A loop must have a constant radius and must be flown in the vertical plane throughout. Loops, including snaps or rolls, must have all rotations within the radius of the loop.
Rolls:	Rolls may be flown individually or as part of other maneuvers. The rate of roll must be constant, with a well-defined start and stop. Point rolls must hesitate equally at each point. When flown correctly, there should not be any pitch up or down to start the roll. A roll should also start and end on the same line of travel. This requires coordination between the rudder and elevator to hold the aircraft on-line throughout the rotation.
Loop/Roll Combo:	F3A competitions include combinations of rolls with loops or circles, requiring coordination of all 4 channels. Keep your aircraft on the circular path with tail control while executing rolls with the ailerons.
Spins:	All spins start and end on horizontal lines. The model must be stalled so that the entry is near horizontal in a nose-high attitude, with the nose rising as speed decreases. The nose drops as the aircraft stalls. At the same time, the wing drops in the direction of the spin. Attempt to make your aircraft enter a spin directly in front of you.
Snaps:	A snap roll is a rapid rotation where the aircraft's nose makes a visible break in heading from its track in pitch and yaw for the duration of the roll. Practice is required to get the aircraft to start and stop at the desired rotation, as well as to keep the aircraft from losing too much energy.
Stall Turns (Hammerhead):	A Stall Turn or Hammerhead is a change of flight direction at stall speed in the vertical plane. The model should turn in a space no wider than 1.5 times the width of the wing span.

Service of Power Components

Disassembly

1. Remove the screw (A) and spinner (B) from the collet (G).
2. Remove the spinner nut (C), propeller (D), spinner back plate (E), backplate (F) and collet from the motor shaft (H). You will need a tool to turn the spinner nut.
3. Remove 2 screws (I) from inside the cowling (J). Carefully remove the cowling from the fuselage. Paint may keep the cowling attached to the fuselage.
4. Remove the 4 screws (K) from the motor mount (O) and the fuselage (L).
5. Disconnect the motor wires from the ESC wires.
6. Remove the 4 screws (M) and motor (N) from the motor mount.

Assembly

Assemble in reverse order.

1. Correctly align and connect the motor wire colors with the ESC wires.
2. The propeller size numbers (14 x 7) must face out from the motor for correct propeller operation.
3. A tool is required to tighten the spinner nut on the collet.

Not all wiring shown.

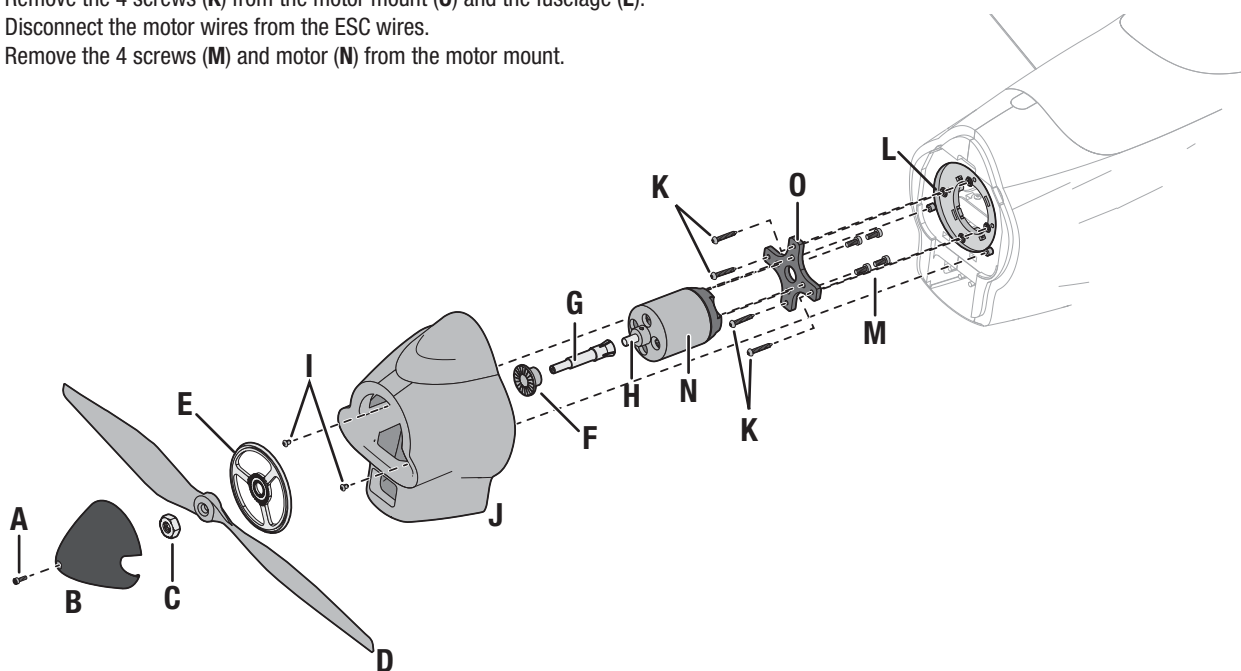

An Advanced Precision Composites "APC" brand propeller has been selected for use with your E-flite Splendor aircraft. This propeller was installed at the factory and it is designed for use on model airplanes only. Proper inspection, balance and installation are required for safe operation.

⚠ CAUTION: Always keep hands away from the propeller. When armed, the motor will turn the propeller in response to any throttle movement.

Propeller Warnings and Precautions

Failure to comply with these warnings and/or improperly using this propeller may result in serious injury. Read all safety precautions and warnings before use.

- Always keep body parts, hair and loose clothing away from the propeller. Failure to do so can result in injury and damage
- Always keep loose objects away from the propeller, including dirt, gravel, tools, string and paper
- Always ensure spectators, especially children, are at least 30 feet (9 meters) away when operating the aircraft
- Always ensure the propeller and all fasteners are securely attached before EACH flight. Propellers may loosen or sustain damage during flight, landing, crashes or storage

- Always stand behind the propeller when making adjustments to your aircraft
- Always confirm a propeller is correctly balanced before installation
- Always use the correct size and pitch of propeller for your aircraft
- Always discard any propeller that is warped, nicked, scratched, cracked or damaged in any way
- Always ensure an installed spinner does not touch the propeller to avoid vibration and abrasion
- Never put or throw any object into a moving propeller for any reason. Remove power from the motor to stop the propeller
- Never accidentally expose the propeller to excessive heat or cold. Failure to do so can result in damage
- Never attempt to repair or modify a propeller beyond its intended use

AMA National Model Aircraft Safety Code

Effective January 1, 2011

A. GENERAL

A model aircraft is a non-human-carrying aircraft capable of sustained flight in the atmosphere. It may not exceed limitations of this code and is intended exclusively for sport, recreation and/or competition. All model flights must be conducted in accordance with this safety code and any additional rules specific to the flying site.

1. Model aircraft will not be flown:
 - (a) In a careless or reckless manner.
 - (b) At a location where model aircraft activities are prohibited.
2. Model aircraft pilots will:
 - (a) Yield the right of way to all man carrying aircraft.
 - (b) See and avoid all aircraft and a spotter must be used when appropriate. (AMA Document #540-D-See and Avoid Guidance.)
 - (c) Not fly higher than approximately 400 feet above ground level within three (3) miles of an airport, without notifying the airport operator.
 - (d) Not interfere with operations and traffic patterns at any airport, heliport or seaplane base except where there is a mixed use agreement.
 - (e) Not exceed a takeoff weight, including fuel, of 55 pounds unless in compliance with the AMA Large Model Aircraft program. (AMA Document 520-A)
 - (f) Ensure the aircraft is identified with the name and address or AMA number of the owner on the inside or affixed to the outside of the model aircraft. (This does not apply to model aircraft flown indoors).
 - (g) Not operate aircraft with metal-blade propellers or with gaseous boosts except for helicopters operated under the provisions of AMA Document #555.
 - (h) Not operate model aircraft while under the influence of alcohol or while using any drug which could adversely affect the pilot's ability to safely control the model.
 - (i) Not operate model aircraft carrying pyrotechnic devices which explode or burn, or any device which propels a projectile or drops any object that creates a hazard to persons or property.

Exceptions:

 - Free Flight fuses or devices that burn producing smoke and are securely attached to the model aircraft during flight.
 - Rocket motors (using solid propellant) up to a G-series size may be used provided they remain attached to the model during flight. Model rockets may be flown in accordance with the National Model Rocketry Safety Code but may not be launched from model aircraft.
 - Officially designated AMA Air Show Teams (AST) are authorized to use devices and practices as defined within the Team AMA Program Document (AMA Document #718).
 - (j) Not operate a turbine-powered aircraft, unless in compliance with the AMA turbine regulations. (AMA Document #510-A).
3. Model aircraft will not be flown in AMA sanctioned events, air shows or model demonstrations unless:
 - (a) The aircraft, control system and pilot skills have successfully demonstrated all maneuvers intended or anticipated prior to the specific event.
 - (b) An inexperienced pilot is assisted by an experienced pilot.
4. When and where required by rule, helmets must be properly worn and fastened. They must be OSHA, DOT, ANSI, SNELL or NOCSAE approved or comply with comparable standards.

B. RADIO CONTROL

1. All pilots shall avoid flying directly over unprotected people, vessels, vehicles or structures and shall avoid endangerment of life and property of others.
2. A successful radio equipment ground-range check in accordance with manufacturer's recommendations will be completed before the first flight of a new or repaired model aircraft.
3. At all flying sites a safety line(s) must be established in front of which all flying takes place (AMA Document #706-Recommended Field Layout):
 - (a) Only personnel associated with flying the model aircraft are allowed at or in front of the safety line.
 - (b) At air shows or demonstrations, a straight safety line must be established.
 - (c) An area away from the safety line must be maintained for spectators.
 - (d) Intentional flying behind the safety line is prohibited.
4. RC model aircraft must use the radio-control frequencies currently allowed by the Federal Communications Commission (FCC). Only individuals properly licensed by the FCC are authorized to operate equipment on Amateur Band frequencies.
5. RC model aircraft will not operate within three (3) miles of any pre-existing flying site without a frequency-management agreement (AMA Documents #922-Testing for RF Interference; #923- Frequency Management Agreement)
6. With the exception of events flown under official AMA Competition Regulations, excluding takeoff and landing, no powered model may be flown outdoors closer than 25 feet to any individual, except for the pilot and the pilot's helper(s) located at the flight line.
7. Under no circumstances may a pilot or other person touch a model aircraft in flight while it is still under power, except to divert it from striking an individual. This does not apply to model aircraft flown indoors.
8. RC night flying requires a lighting system providing the pilot with a clear view of the model's attitude and orientation at all times.
9. The pilot of a RC model aircraft shall:
 - (a) Maintain control during the entire flight, maintaining visual contact without enhancement other than by corrective lenses prescribed for the pilot.
 - (b) Fly using the assistance of a camera or First-Person View (FPV) only in accordance with the procedures outlined in AMA Document #550.

Please see your local or regional modeling association's guidelines for proper, safe operation of your model aircraft.

Federal Aviation Administration

Prior to flying, contact your local or regional modeling organizations for guidance and familiarize yourself with the current local rules and FAA regulations governing model aviation in your location.

More information about model aviation can be found at www.modelaircraft.org. The Federal Aviation Administration can be found online at www.faa.gov.

Troubleshooting Guide AS3X

Problem	Possible Cause	Solution
Oscillation	Flying over recommended airspeed	Reduce air speed
	Damaged propeller or spinner	Replace propeller or spinner
	Imbalanced propeller	Balance the propeller. For more information, view John Redman's propeller balancing video at www.horizonhobby.com
	Flight condition variations	Adjust gain to current flight conditions (wind, updrafts, local conditions [elevation, humidity, temperature, etc.])
	Motor vibration	Replace parts or correctly align all parts and tighten fasteners as needed
	Loose receiver	Align and secure receiver in fuselage
	Loose aircraft controls	Tighten or otherwise secure parts (servo, arm, linkage, horn and control surface)
	Worn parts	Adjust gain to compensate for parts wear or replace worn parts (especially propeller, pivot points or servo)
	Irregular servo rotation	Replace servo
	Incorrect transmitter type (computerized or non-computerized) assigned in receiver	Assign correct transmitter type in the receiver (refer to receiver manual)
If oscillation persists...	Decrease gain (refer to receiver manual)	
Trim change when flight mode is switched	Trim is not at neutral	If you adjust trim more than 8 clicks, adjust the clevis to remove trim
	Sub-Trim is not at neutral	No Sub-Trim is allowed. Adjust the servo arm or the clevis
Incorrect response to the AS3X Control Direction Test	Incorrect direction settings in the receiver, which can cause a crash	DO NOT fly. Correct the direction settings (refer to the receiver manual), then fly.
Channel 5 switch position 0 is 3D and position 1 is F3A	In your transmitter, Channel 5 servo is set to REVERSE	In your transmitter, set Channel 5 servo to NORMAL

Troubleshooting Guide

Problem	Possible Cause	Solution
Aircraft will not respond to throttle but responds to other controls	Throttle not at idle and/or throttle trim too high	Reset controls with throttle stick and throttle trim at lowest setting
	Throttle servo travel is lower than 100%	Make sure throttle servo travel is 100% or greater
	Throttle channel is reversed	Reverse throttle channel on transmitter
	Motor disconnected from ESC	Make sure motor is connected to the ESC
Extra propeller noise or extra vibration	Damaged propeller and spinner, collet or motor	Replace damaged parts
	Propeller is out of balance	Balance or replace propeller
	Prop nut is too loose	Tighten the prop nut
	Spinner is not tight or fully seated in place	Tighten the spinner or remove the spinner and turn it 180 degrees
Reduced flight time or aircraft under-powered	Flight battery charge is low	Completely recharge flight battery
	Propeller installed backwards	Install propeller with numbers facing forward
	Flight battery damaged	Replace flight battery and follow flight battery instructions
	Flight conditions may be too cold	Make sure battery is warm before use
	Battery capacity too low for flight conditions	Replace battery or use a larger capacity battery
Aircraft will not Bind (during binding) to transmitter	Transmitter too near aircraft during binding process	Move powered transmitter a few feet from aircraft, disconnect and reconnect flight battery to aircraft
	Aircraft or transmitter is too close to large metal object, wireless source or another transmitter	Move aircraft and transmitter to another location and attempt binding again
	The bind plug is not installed correctly in the bind port	Install bind plug in bind port and bind the aircraft to the transmitter
	Flight battery/transmitter battery charge is too low	Replace/recharge batteries
	Bind switch or button not held long enough during bind process	Power off transmitter and repeat bind process. Hold transmitter bind button or switch until receiver is bound
	ESC is powered off	Power on the ESC switch
Aircraft will not connect (after binding) to transmitter	Transmitter too near aircraft during connecting process	Move powered transmitter a few feet from aircraft, disconnect and reconnect flight battery to aircraft
	Aircraft or transmitter is too close to large metal object, wireless source or another transmitter	Move aircraft and transmitter to another location and attempt connecting again
	Bind plug left installed in bind port	Rebind transmitter to the aircraft and remove the bind plug before cycling power
	Aircraft bound to different model memory (ModelMatch™ radios only)	Select correct model memory on transmitter
	Flight battery/Transmitter battery charge is too low	Replace/recharge batteries
	Transmitter may have been bound using different DSM protocol	Bind aircraft to transmitter
	ESC is powered off	Power on the ESC switch
Control surface does not move	Control surface, control horn, linkage or servo damage	Replace or repair damaged parts and adjust controls
	Wire damaged or connections loose	Do a check of wires and connections, connect or replace as needed
	Transmitter is not bound correctly or the incorrect model was selected	Re-bind or select correct model in transmitter
	Flight battery charge is low	Fully recharge flight battery
	BEC (Battery Elimination Circuit) of the ESC is damaged	Replace ESC
	ESC is powered off	Power on the ESC switch
Controls reversed	Transmitter settings are reversed	Perform the Control Direction Test and adjust the controls on transmitter appropriately
Motor power pulses then motor loses power	ESC uses default soft Low Voltage Cutoff (LVC)	Recharge flight battery or replace battery that is no longer performing
	Weather conditions might be too cold	Postpone flight until weather is warmer
	Battery is old, worn out, or damaged	Replace battery
	Battery C rating might be too small	Use recommended battery

Limited Warranty

What this Warranty Covers

Horizon Hobby, Inc. ("Horizon") warrants to the original purchaser that the product purchased (the "Product") will be free from defects in materials and workmanship at the date of purchase.

What is Not Covered

This warranty is not transferable and does not cover (i) cosmetic damage, (ii) damage due to acts of God, accident, misuse, abuse, negligence, commercial use, or due to improper use, installation, operation or maintenance, (iii) modification of or to any part of the Product, (iv) attempted service by anyone other than a Horizon Hobby authorized service center, (v) Product not purchased from an authorized Horizon dealer, or (vi) Product not compliant with applicable technical regulations.

OTHER THAN THE EXPRESS WARRANTY ABOVE, HORIZON MAKES NO OTHER WARRANTY OR REPRESENTATION, AND HEREBY DISCLAIMS ANY AND ALL IMPLIED WARRANTIES, INCLUDING, WITHOUT LIMITATION, THE IMPLIED WARRANTIES OF NON-INFRINGEMENT, MERCHANTABILITY AND FITNESS FOR A PARTICULAR PURPOSE. THE PURCHASER ACKNOWLEDGES THAT THEY ALONE HAVE DETERMINED THAT THE PRODUCT WILL SUITABLY MEET THE REQUIREMENTS OF THE PURCHASER'S INTENDED USE.

Purchaser's Remedy

Horizon's sole obligation and purchaser's sole and exclusive remedy shall be that Horizon will, at its option, either (i) service, or (ii) replace, any Product determined by Horizon to be defective. Horizon reserves the right to inspect any and all Product(s) involved in a warranty claim. Service or replacement decisions are at the sole discretion of Horizon. Proof of purchase is required for all warranty claims. SERVICE OR REPLACEMENT AS PROVIDED UNDER THIS WARRANTY IS THE PURCHASER'S SOLE AND EXCLUSIVE REMEDY.

Limitation of Liability

HORIZON SHALL NOT BE LIABLE FOR SPECIAL, INDIRECT, INCIDENTAL OR CONSEQUENTIAL DAMAGES, LOSS OF PROFITS OR PRODUCTION OR COMMERCIAL LOSS IN ANY WAY, REGARDLESS OF WHETHER SUCH CLAIM IS BASED IN CONTRACT, WARRANTY, TORT, NEGLIGENCE, STRICT LIABILITY OR ANY OTHER THEORY OF LIABILITY, EVEN IF HORIZON HAS BEEN ADVISED OF THE POSSIBILITY OF SUCH DAMAGES. Further, in no event shall the liability of Horizon exceed the individual price of the Product on which liability is asserted. As Horizon has no control over use, setup, final assembly, modification or misuse, no liability shall be assumed nor accepted for any resulting damage or injury. By the act of use, setup or assembly, the user accepts all resulting liability. If you as the purchaser or user are not prepared to accept the liability associated with the use of the Product, purchaser is advised to return the Product immediately in new and unused condition to the place of purchase.

Law

These terms are governed by Illinois law (without regard to conflict of law principals). This warranty gives you specific legal rights, and you may also have other rights which vary from state to state. Horizon reserves the right to change or modify this warranty at any time without notice.

WARRANTY SERVICES

Questions, Assistance, and Services

Your local hobby store and/or place of purchase cannot provide warranty support or service. Once assembly, setup or use of the Product has been started, you must contact your local distributor or Horizon directly. This will enable Horizon to better answer your questions and service you in the event that you may need any assistance. For questions or assistance, please visit our website at www.horizonhobby.com, submit a Product Support Inquiry, or call 877.504.0233 toll free to speak to a Product Support representative.

Inspection or Services

If this Product needs to be inspected or serviced and is compliant in the country you live and use the Product in, please use the Horizon Online Service Request submission process found on our website or call Horizon to obtain a Return Merchandise Authorization (RMA) number. Pack the Product securely using a shipping carton. Please note that original boxes may be included, but are not designed to withstand the rigors of shipping without additional protection. Ship via a carrier that provides tracking and insurance for lost or damaged parcels, as Horizon is not responsible for merchandise until it arrives and is accepted at our facility. An Online Service Request is available at http://www.horizonhobby.com/content/_service-center_render-service-center. If you do not have internet access, please contact Horizon Product Support to obtain a RMA number along with instructions for submitting your product for service. When calling Horizon, you will be asked to provide your complete name, street address, email address and phone number where you can be reached during business hours. When sending product into Horizon, please include your RMA number, a list of the included items, and a brief summary of the problem. A copy of your original sales receipt must be included for warranty consideration. Be sure your name, address, and RMA number are clearly written on the outside of the shipping carton.

NOTICE: Do not ship LiPo batteries to Horizon. If you have any issue with a LiPo battery, please contact the appropriate Horizon Product Support office.

Warranty Requirements

For Warranty consideration, you must include your original sales receipt verifying the proof-of-purchase date. Provided warranty conditions have been met, your Product will be serviced or replaced free of charge. Service or replacement decisions are at the sole discretion of Horizon.

Non-Warranty Service

Should your service not be covered by warranty, service will be completed and payment will be required without notification or estimate of the expense unless the expense exceeds 50% of the retail purchase cost. By submitting the item for service you are agreeing to payment of the service without notification. Service estimates are available upon request. You must include this request with your item submitted for service. Non-warranty service estimates will be billed a minimum of ½ hour of labor. In addition you will be billed for return freight. Horizon accepts money orders and cashier's checks, as well as Visa, MasterCard, American Express, and Discover cards. By submitting any item to Horizon for service, you are agreeing to Horizon's Terms and Conditions found on our website http://www.horizonhobby.com/content/_service-center_render-service-center.

ATTENTION: Horizon service is limited to Product compliant in the country of use and ownership. If received, a non-compliant Product will not be serviced. Further, the sender will be responsible for arranging return shipment of the un-serviced Product, through a carrier of the sender's choice and at the sender's expense. Horizon will hold non-compliant Product for a period of 60 days from notification, after which it will be discarded.

Contact Information

Country of Purchase	Horizon Hobby	Address	Phone Number/Email Address
United States of America	Horizon Service Center (Electronics and engines)	4105 Fieldstone Rd Champaign, Illinois 61822 USA	877-504-0233 Online Repair Request: visit www.horizonhobby.com/service
	Horizon Product Support (All other products)	4105 Fieldstone Rd Champaign, Illinois 61822 USA	877-504-0233 productsupport@horizonhobby.com
United Kingdom	Horizon Hobby Limited	Units 1-4 Ployters Rd Staple Tye Harlow, Essex CM18 7NS United Kingdom	+44 (0) 1279 641 097 sales@horizonhobby.co.uk
Germany	Horizon Technischer Service	Christian-Junge-Straße 1 25337 Elmshorn Germany	+49 (0) 4121 2655 100 service@horizonhobby.de
France	Horizon Hobby SAS	11 Rue Georges Charpak 77127 Lieusaint, France	+33 (0) 1 60 18 34 90 infofrance@horizonhobby.com
China	Horizon Hobby – China	Room 506, No. 97 Changshou Rd. Shanghai, China, 200060	+86 (021) 5180 9868 info@horizonhobby.com.cn

Compliance Information for the European Union

Declaration of Conformity

(in accordance with ISO/IEC 17050-1)

No. HH2012112203

Product(s): EFL Carbon-Z Splendor BNF Basic
Item Number(s): EFL10250
Equipment class: 1

The object of declaration described above is in conformity with the requirements of the specifications listed below, following the provisions of the European R&TTE directive 1999/5/EC and EMC Directive 2004/108/EC:

EN 301 489-1 V1.7.1: 2006

EN 301 489-17 V1.3.2: 2008

EN55022:2010 + AC:2011

EN55024:2010



Signed for and on behalf of:
Horizon Hobby, Inc.
Champaign, IL USA
Nov 22, 2012

Steven A. Hall
Executive Vice President and Chief Operating Officer
International Operations and Risk Management
Horizon Hobby, Inc

Instructions for disposal of WEEE by users in the European Union



This product must not be disposed of with other waste. Instead, it is the user's responsibility to dispose of their waste equipment by handing it over to a designated collection point for the recycling of waste electrical and electronic equipment. The separate collection and recycling of your waste equipment at the time of disposal will help to conserve natural resources and ensure that it is recycled in a manner that protects human health and the environment. For more information about where you can drop off your waste equipment for recycling, please contact your local city office, your household waste disposal service or where you purchased the product.

Parts Contact Information • Kontaktinformationen für Ersatzteile • Coordonnées pour obtenir des pièces détachées • Recapiti per i ricambi

Country of Purchase	Horizon Hobby	Address	Phone Number/Email Address
United States of America	Sales	4105 Fieldstone Rd Champaign, Illinois 61822 USA	800-338-4639 Sales@horizonhobby.com
United Kingdom	Horizon Hobby Limited	Units 1-4 Ployters Rd Staple Tye Harlow, Essex CM18 7NS, United Kingdom	+44 (0) 1279 641 097 sales@horizonhobby.co.uk
Germany	Horizon Hobby GmbH	Christian-Junge-Straße 1 25337 Elmshorn, Germany	+49 (0) 4121 2655 100 service@horizonhobby.de
France	Horizon Hobby SAS	11 Rue Georges Charpak 77127 Lieusaint, France	+33 (0) 1 60 18 34 90 infofrance@horizonhobby.com
China	Horizon Hobby – China	Room 506, No. 97 Changshou Rd. Shanghai, China, 200060	+86 (021) 5180 9868 info@horizonhobby.com.cn

Replacement Parts • Ersatzteile • Pièces de rechange • Pezzi di ricambio

Part # Nummer Numéro Codice	Description	Beschreibung	Description	Descrizione
EFL10250	Carbon-Z Splendor BNF Basic	E-flite Carbon-Z Splendor BNF Basic	E-flite Carbon-Z Splendor BNF Basic	Carbon-Z Splendor BNF Basic
EFL1025001	Fuselage: C-Z Splendor	E-flite Carbon-Z Splendor: Rumpf	Carbon-Z Splendor -Fuselage	Fusoliera: C-Z Splendor
EFL1025002	Wing Set: C-Z Splendor	E-flite Carbon-Z Splendor: Tragflächenset	Carbon-Z Splendor -Aile	Set ala: C-Z Splendor
EFL1025003	Stab Set: C-Z Splendor	E-flite Carbon-Z Splendor: Höhenruderset	Carbon-Z Splendor -Stabilisateur	Set stabilizzatore: C-Z Splendor
EFL1025004	Rudder w/Tail Gear: C-Z Splendor	E-flite Carbon-Z Splendor: Seitenruder m. Spornrad	Carbon-Z Splendor -Dérive avec jambe de train arrière	Timone c/carrello coda: C-Z Splendor
EFL1025005	Cowling:C-Z Splendor	E-flite Carbon-Z Splendor: Motorhaube	Carbon-Z Splendor -Capot	Capottina motore:C-Z Splendor
EFL1025006	Canopy Hatch: C-Z Splendor	E-flite Carbon-Z Splendor: Kabinenhaube	Carbon-Z Splendor -Trappe supérieure	Portello capottina: C-Z Splendor
EFL1025007	Landing Gear Set: C-Z Splendor	E-flite Carbon-Z Splendor: Hauptfahrwerk u. Spornrad	Carbon-Z Splendor -Set de jambes de train principal et arrière	Set carrello: C-Z Splendor
EFL1025008	Wing & Stab Tube: C-Z Splendor	E-flite Carbon-Z Splendor: Tragflächen- u. Leitwerksverbinder	Carbon-Z Splendor -Clé d'aile et de stabilisateur	Tubo ala e stabilizzatore: C-Z Splendor
EFL1025009	Fairings & Wheel Pants:C-Z Splendor	E-flite Carbon-Z Splendor: Fahrwerksverkleidungen u. Radschuhe	Carbon-Z Splendor -Carénages et chapeaux de roues	Carenature gambe e ruote carrello:C-Z Splendor
APC14070E	Thin Electric Propeller, 14 x 7E	APC Elektro Propeller 14 x 7	Hélice électrique APC , 14x7E	Elica sottile per motore elettrico, 14 x 7E
EFL1025011	Spinner: C-Z Splendor	E-flite Carbon-Z Splendor: Spinner	Carbon-Z Splendor -Cône	Ogiva: C-Z Splendor
EFLM7450	BL50 Brushless Outrunner Motor, 525Kv	E-flite Carbon-Z Splendor: BL50 Brushless Aussenläufer 525 Kv	Moteur brushless BL50 à cage tournante, 525Kv	BL50 Brushless Outrunner Motor, 525Kv
EFL1025012	Control Horn & Linkage Set: C-Z Splendor	E -flite Carbon-Z Splendor: Ruderhorn u. Anlenkungsset	Carbon-Z Splendor -Set de tringleries et de guignols	Set squadrette e comandi: C-Z Splendor
EFL1025013	Battery Tray: C-Z Splendor	E -flite Carbon-Z Splendor: Akkuträger	Carbon-Z Splendor -Support de batterie	Supporto batteria: C-Z Splendor
EFL1025014	Screw Set: C-Z Splendor	E -flite Carbon-Z Splendor: Schraubenset	Carbon-Z Splendor -Set de visserie	Set viti: C-Z Splendor
EFLR71454	Plastic Servo Arm: 26g Digital MG Mini Servo	E-flite Servohorn Kunststoff: 26g Digital MG Mini Servo	Bras de servo en plastique	Bracci servi in plastica: 26g Digital MG Mini Servo
EFL1025016	CA Hinges Set: C-Z Splendor	E-flite Carbon-Z Splendor: CA Scharniere	Jeu de charnières CA	Set cerniere CA: C-Z Splendor
EFL1025017	Decal Set: C-Z Splendor	E-flite Carbon-Z Splendor: Dekorbogen	Carbon-Z Splendor -Set d'autocollants	Set adesivi: C-Z Splendor

Part # Nummer Numéro Codice	Description	Beschreibung	Description	Descrizione
EFL1025018	Motor Mount Set: C-Z Splendor	E-flite Carbon-Z Splendor: Aluminium Motor u. Kunststoffing	Carbon-Z Splendor -Support moteur	Set supporto motore: C-Z Splendor
EFLM74501	Motor Shaft: BL50 Outrunner motor, 525Kv	E-flite Carbon-Z Splendor BL50 Aussenläufer Motor 525 Kv: Motorwelle	Axe pour moteur BL50, 525Kv	Albero motore: BL50 Outrunner motor, 525Kv
EFLM74502	Prop Adapter: BL50 Outrunner mo- tor, 525Kv	E-flite Carbon-Z Splendor: BL50 Aussenläufer Motor 525 Kv: Propelleradapter	Adaptateur d'hélice pour moteur BL50, 525Kv	Adattatore elica: BL50 Outrunner motor, 525Kv
EFLA1060B	60-Amp Pro Switch-Mode BEC Brushless ESC (V2)	E-flite 60-Amp Pro Switch-Mode BEC Brushless Regler (V2)	Contrôleur brushless 60A Pro switch Mode BEC (V2)	60-Amp Pro Switch-Mode BEC Brushless ESC (V2)
EFLAEC308	EC3 Battery Series Y-Harness	E-flite EC3 Akkukabel seriell, Silikon 13GA	Cordon Y pour batteries, prises EC3	Adattatore a Y per batteria EC3
SPMAR635	Spektrum 6-Channel AS3X Sport Receiver	Spektrum 6 Kanal AS3X Sport Empfänger	Récepteur Spektrum 6 voies à la technologie AS3X	Ricevitore Spektrum 6-canali AS3X Sport
EFLR7145	26 g Digital MG Mini Servo	E-flite 26g Digital MG Mini Servo	Mini servo digital 26g à pignons métal	26 g Digital MG Mini Servo

Optional Parts • Optionale Bauteile • Pièces optionnelles • Pezzi opzionali

Part # Nummer Numéro Codice	Description	Beschreibung	Description	Descrizione
EFLB32006S30	E-flite 6S 22.2V 3200mAh 30C Li-Po Battery Pack	E-flite 6S 22.2V 3200mAh 30C Li-Po Akku	Batterie Li-Po E-flite 22.2V 6S 3200mA 30C	Batteria E-flite 6S 22.2V 3200mAh 30C Li-Po
EFLB29006S30	E-flite 6S 22.2V 2900mAh 30C Li-Po Battery Pack, 13AWG EC3	E-flite 2900mAh 6S 22.2V 30C LiPo, 13AWG EC3	Batterie Li-Po E-flite 22.2V 6S 2900mA 30C, prise EC3	Batteria E-flite 6S 22.2V 2900mAh 30C Li-Po, 13AWG EC3
EFLAB32003S30	E-flite 3S 11.1V 3200mAh 30C Li-Po Battery Pack (2 required)	E-flite 3S 11.1V 3200mAh 30C Li-Po Akku Pack (2 erforderlich)	Batterie Li-Po E-flite 11.1V 3S 3200mA 30C (2 batteries requises)	Batteria E-flite 3S 11.1V 3200mAh 30C Li-Po (2 required)
EFLAEC302	EC3 Battery Connector, Female (2)	EC3 Akkukabel, Buchse (2)	Prise EC3 femelle (2pc)	EC3 Connettore femmina x batteria (2)
EFLAEC303	EC3 Device/Battery Connector, Male/Female	EC3 Kabelsatz, Stecker/Buchse	Prise EC3 male/femelle	EC3 Connettore batteria maschio/ femmina
EFLC3025	Celectra 80W AC/DC Multi-Chemistry Battery Charger	Celectra 80 W AC/DC Multi-Chemistry-Batterieladegerät	Chargeur de batterie AC/DC Celectra 80 W multi-types	Caricabatterie per batteria multichimica 80 W c.a./c.c.
EFLC3020	200W DC multi-chemistry battery charger	200W DC Multi-Batterie Ladegerät - EU	Chargeur multiple DC 200W	200W DC Caricabatterie universale
EFLC4010	Celectra 15VDC 250W Power Supply	Celectra 15 V DC 250-W-Netzstecker	Alimentation Celectra CC 15 V 250 W	Alimentatore Celectra 15V c.c., 250 W
EFLA261	Micro/Mini Heli Tool Assortment	Micro/Mini-Helikopter-Werkzeugsatz	Assortiment d'outils micro / mini pour hélicoptère	Assortimento utensili per micro/mini elicotteri
RV01005	Ball Link Pliers	Revolution: Kugelkopfzange	Pince pour rotules	Pinze per attacchi a sfera
	DX6i DSMX 6-Channel Transmitter	Spektrum DX6i DSMX 6-Kanal Sender	Emetteur DX6i DSMX 6 voies	DX6i DSMX Trasmettitore 6 canali
	DX7s DSMX 7-Channel Transmitter	Spektrum DX7s DSMX 7 Kanal Sender	Emetteur DX7s DSMX 7 voies	DX7s DSMX Trasmettitore 7 canali
	DX8 DSMX 8-Channel Transmitter	Spektrum DX8 DSMX 8 Kanal Sender	Emetteur DX8 DSMX 8 voies	DX8 DSMX Trasmettitore 8 canali
	DX10t DSMX 10-Channel Transmitter	Spektrum DX10t DSMX 10 Kanal Sender	Emetteur DX10t DSMX 10 voies	DX10t DSMX Trasmettitore 10 canali
	DX18 DSMX 18-Channel Transmitter	Spektrum DX18 DSMX 18 Kanal Sender	Emetteur DX18 DSMX 18 voies	DX18 DSMX Trasmettitore 18 canali
	DX18QQ DSMX 18-Channel Transmitter	Spektrum DX18QQ DSMX 18 Kanal Sender	Emetteur DX18QQ DSMX 18 voies	DX18QQ DSMX Trasmettitore 18 canali

© 2013 Horizon Hobby, Inc.

E-flite, Splendor, AS3X, ParkZone, Blade, Celectra, EC3, DSM, DSM2, DSMX, Bind-N-Fly and ModelMatch are trademarks or registered trademarks of Horizon Hobby, Inc.

The Spektrum trademark is used with permission of Bachmann Industries, Inc.

APC and the APC logo are trademarks or registered trademarks of Landing Products, Inc. and are used with permission by Horizon Hobby, Inc.

Futaba is a registered trademark of Futaba Denshi Kogyo Kabushiki Kaisha Corporation of Japan.

All other trademarks, service marks and logos are property of their respective owners.

US 8,201,776

<http://www.e-fliterc.com/>

EFL10250

