

PNP
PLUG-N-PLAY™

C-Ray™ 180



***Instruction Manual
Bedienungsanleitung
Manuel d'utilisation
Manuale di Istruzioni***

E-flite®
ADVANCING ELECTRIC FLIGHT

NOTICE

All instructions, warranties and other collateral documents are subject to change at the sole discretion of Horizon Hobby, Inc. For up-to-date product literature, visit www.horizonhobby.com and click on the support tab for this product.

Meaning of Special Language:

The following terms are used throughout the product literature to indicate various levels of potential harm when operating this product:

NOTICE: Procedures, which if not properly followed, create a possibility of physical property damage AND little or no possibility of injury.

CAUTION: Procedures, which if not properly followed, create the probability of physical property damage AND a possibility of serious injury.

WARNING: Procedures, which if not properly followed, create the probability of property damage, collateral damage, and serious injury OR create a high probability of superficial injury.



WARNING: Read the ENTIRE instruction manual to become familiar with the features of the product before operating. Failure to operate the product correctly can result in damage to the product, personal property and cause serious injury.

This is a sophisticated hobby product. It must be operated with caution and common sense and requires some basic mechanical ability. Failure to operate this product in a safe and responsible manner could result in injury or damage to the product or other property. This product is not intended for use by children without direct adult supervision. Do not use with incompatible components or alter this product in any way outside of the instructions provided by Horizon Hobby, Inc. This manual contains instructions for safety, operation and maintenance. It is essential to read and follow all the instructions and warnings in the manual, prior to assembly, setup or use, in order to operate correctly and avoid damage or serious injury.

Age Recommendation: Not for children under 14 years. This is not a toy.

Safety Precautions and Warnings

- Always keep a safe distance in all directions around your model to avoid collisions or injury. This model is controlled by a radio signal subject to interference from many sources outside your control. Interference can cause momentary loss of control.
- Always operate your model in open spaces away from full-size vehicles, traffic and people.
- Always carefully follow the directions and warnings for this and any optional support equipment (chargers, rechargeable battery packs, etc.).
- Always keep all chemicals, small parts and anything electrical out of the reach of children.
- Always avoid water exposure to all equipment not specifically designed and protected for this purpose. Moisture causes damage to electronics.
- Never place any portion of the model in your mouth as it could cause serious injury or even death.
- Never operate your model with low transmitter batteries.
- Always keep aircraft in sight and under control.
- Always use fully charged batteries.
- Always keep the transmitter powered on while aircraft is powered.
- Always remove batteries before disassembly.
- Always keep moving parts clean.
- Always keep parts dry.
- Always let parts cool after use before touching.
- Always remove batteries after use.
- Always ensure failsafe is properly set before flying.
- Never operate aircraft with damaged wiring.
- Never touch moving parts.

Thank you for purchasing the exciting new E-flite® flying wing, the C-Ray 180 PNP. Constructed of durable Z-Foam™ material, this agile little flying wing is designed to bounce back from mild impacts time and time again. The perfect airplane for parks and small flying areas, the C-Ray™ airplane delivers snappy, fast and fun performance that intermediate through expert pilots will love. With its included decal sheet, personalizing your C-Ray airplane is easy so you can distinguish which airplane is yours when flying with buddies.

Although this great flying plane requires very little assembly out of the box, we encourage you to take a little time to absorb the content of this manual before your first flight. Inside you'll find helpful setup tips, a handy troubleshooting guide and guidelines to help you select appropriate flying fields for this model, as well as important safety considerations.

Box Contents

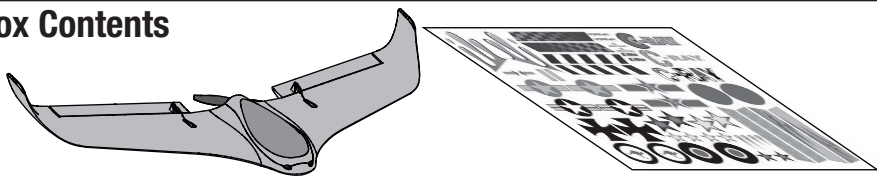
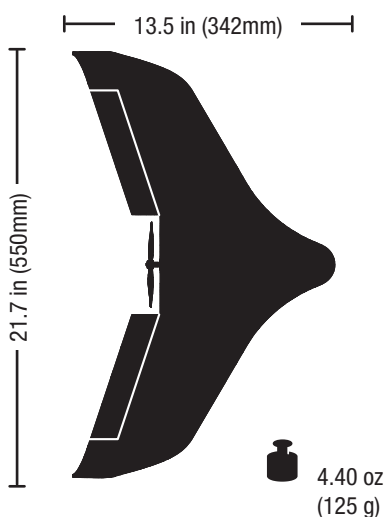

Table of Contents



Preflight Checklist.....	4	Applying Decals.....	10
Battery Selection.....	4	Flying Tips and Repairs.....	11
Low Voltage Cutoff (LVC).....	4	Post Flight Checklist.....	11
Installing a Receiver.....	5	Service of Power Components.....	12
Installing the Flight Battery.....	6	Troubleshooting Guide.....	13
Arming the ESC.....	7	Limited Warranty.....	14
Control Horn and Servo Arm Settings.....	7	Warranty and Service Information.....	15
Transmitter and Model Setup.....	8	Compliance Information for the European Union..	15
Control Direction Test.....	9	Replacement Parts.....	58
Control Centering.....	9	Optional Parts and Accessories.....	59
Adjusting the Center of Gravity (CG).....	10	Parts Contact Information.....	59

Specifications







To register your product online, go to www.e-flite.com

Installed

-  180 Brushless Outrunner Motor, 2500Kv (EFLM7005)
-  8-Amp Brushless ESC (EFLA7200)
-  (2) 3 g Super Sub-Micro Servo (EFLR7105)

Needed to Complete

-  **Recommended Battery:** 450mAh 2S 7.4V 30C Li-Po, 18AWG JST (EFLB4502SJ30)
-  **Recommended Battery Charger:** Celectra™ 80W AC/DC Multi-Chemistry Battery Charger (EFLC3025)
-  **Recommended Receiver:** Spektrum™ AR6310 DSMX Nanolite 6-Channel Receiver, Air (SPMAR6310)
-  **Recommended Transmitter:** Full Range DSM2®/DSMX® technology with adjustable dual rate, exponential and elevon mixing (DX6i and up)

Preflight Checklist

✓	
	1. Charge the flight battery.
	2. Install the flight battery in the aircraft (once it has been fully charged).
	3. Bind the aircraft to the transmitter.
	4. Make sure the linkages move freely.
	5. Perform the Control Direction Test with the transmitter.

✓	
	6. Adjust the center of gravity.
	7. Perform a radio system Range Check.
	8. Find a safe and open area.
	9. Plan flight appropriate for flying location

Battery Selection

We recommend the E-flite 450mAh 2S 7.4V 30C Li-Po, 18AWG JST (EFLB4502SJ30) battery. If using another battery, it must be at least a 20C 430mAh battery. Your battery should be approximately the same capacity, dimensions and weight as the recommended Li-Po battery to fit in the fuselage without changing the center of gravity.

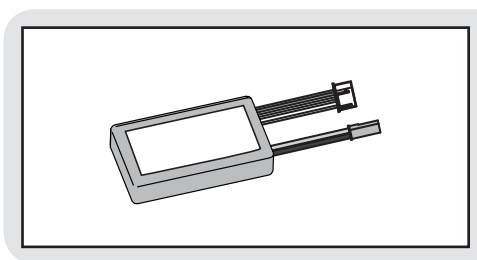

Low Voltage Cutoff (LVC)

When a Li-Po battery is discharged below 3V per cell, it will not hold a charge. The aircraft's ESC protects the flight battery from over-discharge using Low Voltage Cutoff (LVC).

Once the battery discharges to 3V per cell, the LVC will reduce the power to the motor in order to leave adequate power to the receiver and servos to land the airplane.

When the motor power decreases, land the aircraft immediately and replace or recharge the flight battery.

Always disconnect and remove the Li-Po battery from the aircraft after each flight. Charge your Li-Po battery to about half capacity before storage. Make sure the battery charge does not fall below 3V per cell. Failure to disconnect the battery will result in trickle discharge.

For your first flights, set your transmitter timer or a stopwatch to 8 minutes. Adjust your timer for longer or shorter flights once you have flown the model. Flights of 10 minutes are achievable with the recommended battery if using proper throttle management.

NOTICE: Repeated flying to LVC will damage the battery.

Installing a Receiver

Be sure you choose a receiver that uses JST: ZHR-3 micro connectors. We recommend the Spektrum™ AR6310 DSMX Nanolite 6-Channel Receiver (SPMAR6310).

1. Remove the canopy.
2. Install the receiver in the fuselage using the included double-sided servo tape.
3. Connect the left elevon (when facing the rear of the aircraft) servo connector to the elevator channel of the receiver.
4. Connect the right elevon (when facing the rear of the aircraft) servo connector to the aileron channel of the receiver.
5. Connect the ESC connector to the throttle channel of the receiver.

Some JST-type servos have a different polarity than Spektrum servos. Plug the servo leads into the appropriate servo ports in the receiver noting the polarity of the servo connector. See illustration for correct connector polarity.

- (A) Orange Wire: Signal
- (B) Brown Wire (middle wire): Negative
- (C) Red Wire: Positive

Transmitter and Receiver Binding

Refer to your transmitter and receiver manuals for binding instructions.

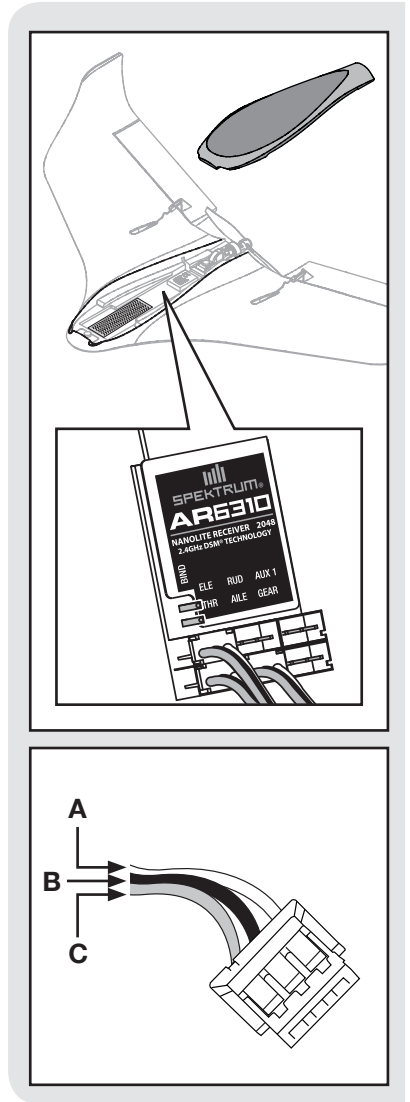

Installing the Flight Battery

1. Remove the canopy.

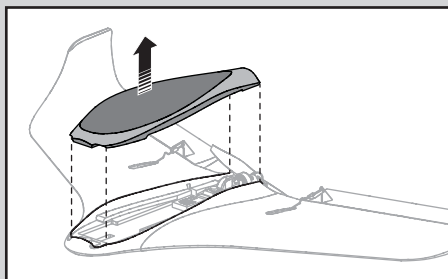

2. Center the included strip of hook and loop tape on the bottom of your battery.

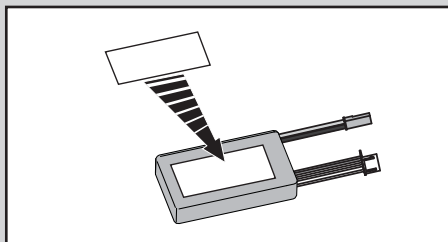

3. Install the battery in the battery cavity, then press the battery onto the hook and loop strip (A). See the Adjusting the Center of Gravity instructions for more information.

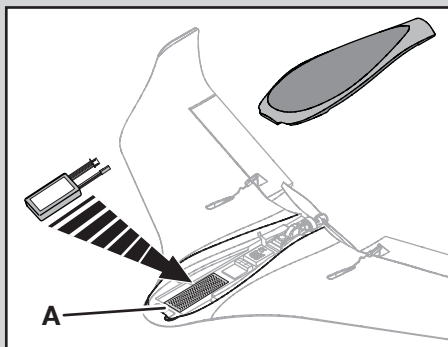

4. Connect the fully charged flight battery to the ESC. See the Arming the ESC instructions for correct connection of the battery to the ESC.

5. Reinstall the canopy.

⚠ CAUTION: Always disconnect the Li-Po battery from the ESC when not flying to eliminate power supplied to the motor. The ESC does not have an arming switch and will respond to any transmitter input when a signal is present.

⚠ CAUTION: Always disconnect the Li-Po battery from the ESC when not flying to avoid over-discharging the battery. Batteries discharged to a voltage lower than the lowest approved voltage may become damaged, resulting in loss of performance and potential fire when batteries are charged.

Arming the ESC

Arming the ESC also occurs after binding, but subsequent connection of a flight battery requires the following steps.

If you accidentally connect the battery while the throttle is fully opened, a musical tone will sound and the ESC will not arm until the throttle is returned to the off position.

⚠ CAUTION: Always keep hands away from the propeller. When armed, the motor will turn the propeller in response to any throttle movement.

1

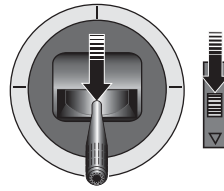

Lower throttle and throttle trim to lowest settings.

⚡ Power ON the transmitter.

2

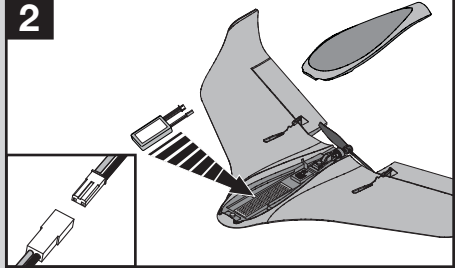

Remove the canopy and install the flight battery on the hook and loop strip, then connect the battery to the ESC, noting proper polarity.

3



🔊 Series of tones

💡 Continuous LED

Control Horn and Servo Arm Settings

This illustration shows the factory settings for linkages on the control horns and servo arms.

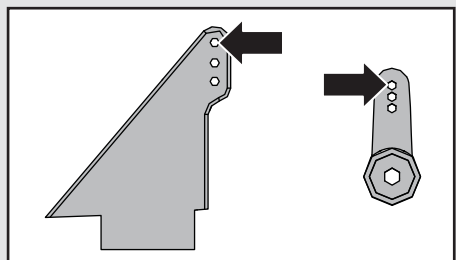

Transmitter and Model Setup

Transmitter Setup

Flying wings are controlled by elevons (the moveable surfaces on the C-Ray wing). Elevons combine aileron and elevator controls and mix them together electronically through the transmitter.

Make sure both elevons move up and down (travel) the same amount. This model tracks well when the left and right elevon travel the same amount in response to the control stick. See the Control Centering instructions for centering the control surfaces.

When using a DX6i transmitter, servo reversing on the elevator channel is required.

When using a DX7s, DX8 or DX18 transmitter, set the transmitter wing configuration to Elevon-B.

Expo

	High	Low
Aileron	10%	0%
Elevator	10%	0%

Dual Rates

	High	Low
Aileron	7mm ▲ / ▼	5mm ▲ / ▼
Elevator	7mm ▲ / ▼	5mm ▲ / ▼

Measuring Control Throws

Below is the location on this aircraft to measure the recommended low and high rate control throws (distance) in both directions.



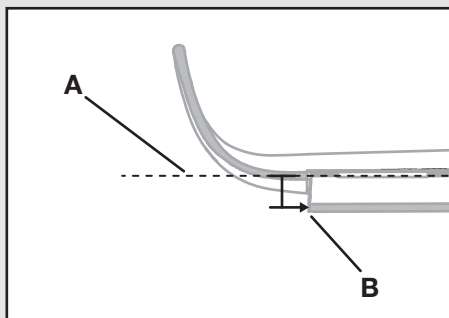

Elevons:

From the center line guide (A) deflect the trailing edge of the elevon (B).



Control Direction Test

Bind your aircraft and transmitter before doing these tests. Move the controls on the transmitter to make sure the aircraft control surfaces move correctly and in the proper direction. **Always keep throttle at the low position during testing.**

	Transmitter Command	Aircraft Reaction
Elevator	Up Elevator Command	
	Down Elevator Command	
Aileron	Stick Right	
	Stick Left	

Control Centering

Before the first flights, or in the event of an accident, make sure the flight control surfaces are centered. Adjust the linkages mechanically if the control surfaces are not centered.

1. Make sure the control surfaces are neutral when the transmitter controls and trims are centered. The transmitter sub-trim must always be set to zero.
2. When needed, use a pair of pliers to carefully bend the metal linkage (see illustration).
3. Make the U-shape narrower to make the connector shorter. Make the U-shape wider to make the linkage longer.

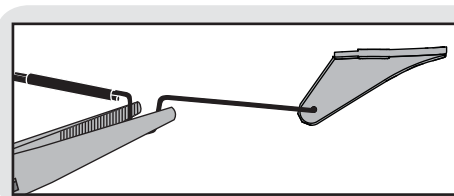

When centering the elevons, the control surface will not directly line up with the edge of the wing tip due to the wing tip's washout. The top of the elevon will line up with the approximate middle of the edge of the wing (see illustration).

Centering Controls After First Flights

If the model requires excessive transmitter trim, return the transmitter trim to zero and adjust the linkages mechanically so that the control surfaces are in the flight trimmed position.

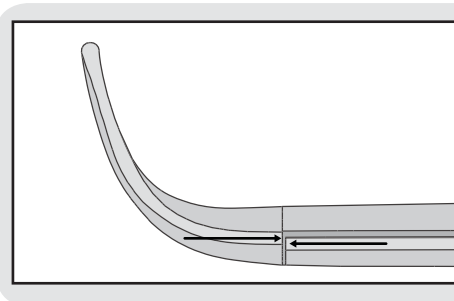

Adjusting the Center of Gravity (CG)

The recommended CG location is 18mm (0.71 inch) forward from the front edge of the servo casing. This CG location has been determined with the recommended 450mAh 2S 7.4V 30C Li-Po battery installed in the battery cavity.

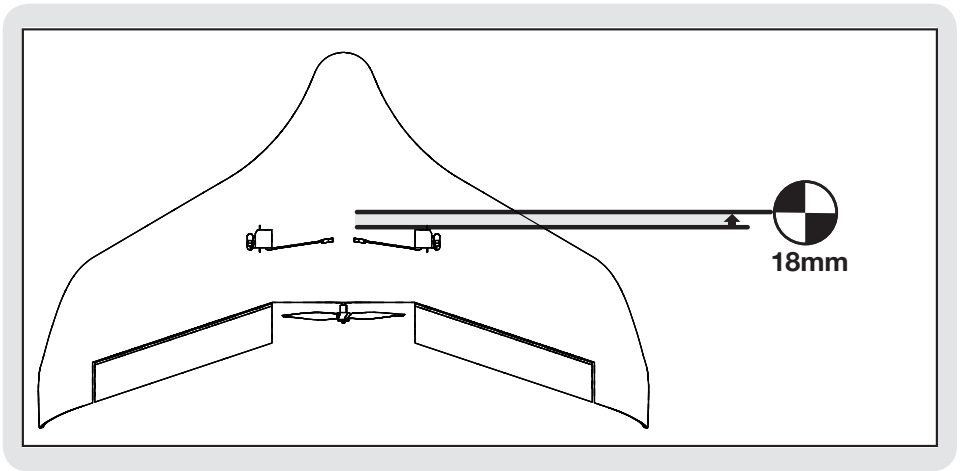

Applying Decals

Customize your aircraft with decals.

1. Ensure the surface area is clean.
2. Cut and remove the desired decals from the decal sheet.
3. Press the decal on the aircraft in the desired location.

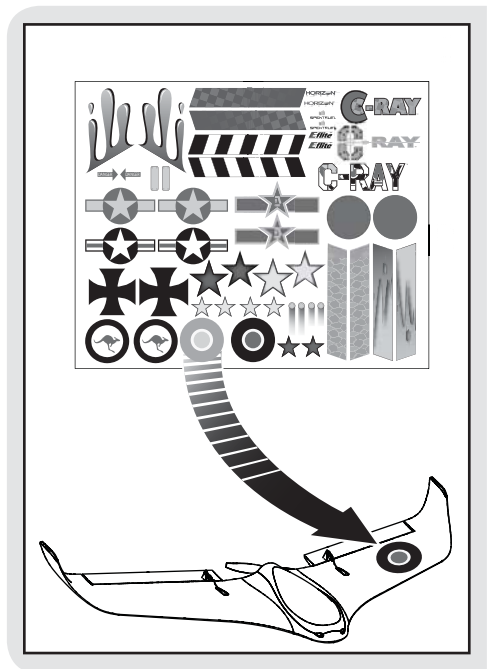

Flying Tips and Repairs

Consult local laws and ordinances before choosing a location to fly your aircraft.

We recommend flying your aircraft outside in no greater than moderate winds.

Always avoid flying near houses, trees, wires and buildings. You should also be careful to avoid flying in areas where there are many people, such as busy parks, schoolyards or soccer fields.

Range Check your Radio System

After final assembly, range check the radio system with the aircraft. Refer to your specific transmitter and receiver instruction manuals for range test information.

CAUTION: Keep hands away from the propeller. Always assume the motor is powered ON and that the propeller blades may turn at any time.

Flying

This aircraft is extremely responsive to control input. Fly at low rate settings until you are familiar with its response.

Fly your first attempts at high rate settings at high altitude and slow speeds.

Hand Launching

When hand-launching your aircraft alone, hold the aircraft in one hand and the transmitter in the other.

Hold the aircraft in the finger grips on the underside of the aircraft. Firmly throw the aircraft directly into the wind, angled slightly up (5 to 10 degrees above the horizon). When the propeller is clear of your hand, apply throttle. Climb to check the trim. Once the trim is adjusted, begin exploring the flight envelope of the aircraft.

Landing

Make sure to land on a soft surface, like grass. Fly the aircraft into the wind approximately 6 inches (15cm) or less above the surface, using a small amount of throttle for the entire descent. Keep throttle on until the aircraft is ready to flare. During flare, keep the wings level and the aircraft pointed into the wind. Before the aircraft touches down, always fully decrease throttle to avoid damage to the propeller, motor, ESC or other components.

CAUTION: Never catch a flying aircraft in your hands. Doing so could cause personal injury and damage to the aircraft.

NOTICE: If a crash is imminent, reduce the throttle and trim fully. Failure to do so could result in extra damage to the airframe, as well as damage to the ESC and motor.

NOTICE: Crash damage is not covered under warranty.

Repairs

Thanks to the Z-Foam™ construction of this aircraft, repairs to the foam can be made using virtually any adhesive (hot glue, regular CA, epoxy, etc). When parts are not repairable, see the Replacement Parts List for ordering by item number. For a listing of all replacement and optional parts, refer to the list at the end of this manual.

NOTICE: Use of CA accelerant on your aircraft can damage paint. DO NOT handle the aircraft until accelerant fully dries.

NOTICE: When you are finished flying, never keep the aircraft in the sun. Do not store the aircraft in a hot, enclosed area such as a car. Doing so can damage the foam.

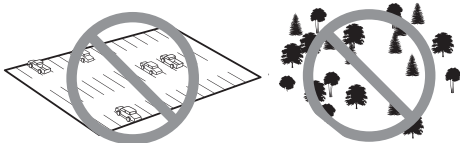

Post Flight Checklist

✓	
	1. Disconnect the flight battery from the ESC (required for safety and battery life).
	2. Power OFF the transmitter.
	3. Remove the flight battery from the aircraft.
	4. Recharge the flight battery.
	5. Store the flight battery apart from the aircraft and monitor the battery charge.
	6. Make note of flight conditions and flight plan results, planning for future flights.

Service of Power Components

Disassembly

⚠ CAUTION: Always disconnect the battery before handling or adjusting the propeller or motor. Failure to do so could result in personal injury.

1. Remove the canopy.
2. Carefully remove the propeller screw (A), washer (B) and propeller (C).
3. Remove the propeller spacer setscrew (D) and propeller spacer (E) from the motor shaft.
4. The motor housing and shaft (F) are magnetically secured to the motor. Remove the motor housing and shaft by pulling them away from the motor. Repair or replace the motor housing and shaft as necessary.
5. Remove the top screw (G) from the firewall to remove the motor (H). The motor magnet may attract screws to the motor.
6. Disconnect the motor wire connectors from the ESC.
7. Remove the motor from the firewall.

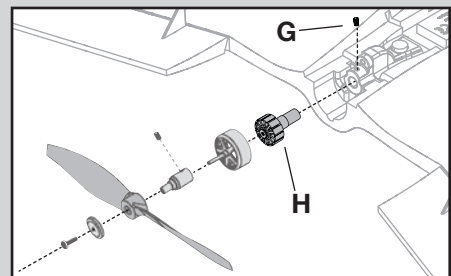
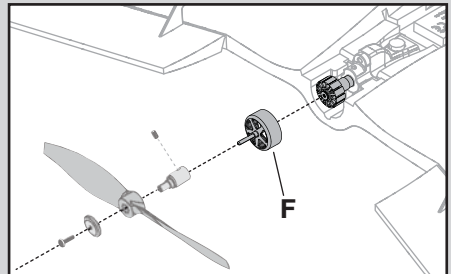
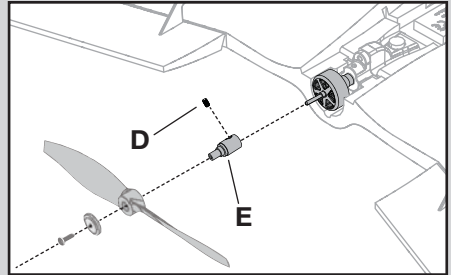
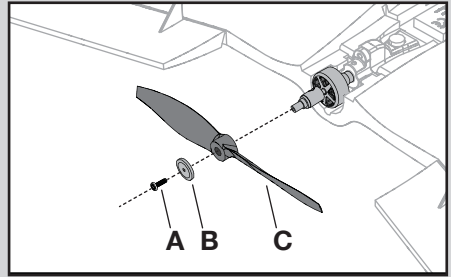

Assemble in reverse order.

- Connect the motor wire connectors to the ESC so that the propeller turns clockwise (facing the rear of the aircraft). If the motor turns in the wrong direction, switch any 2 motor wires.
- The propeller size numbers (4.5 x 4) must face forward towards the front of the aircraft for correct propeller operation.

Troubleshooting Guide

Problem	Possible Cause	Solution
Aircraft will not respond to throttle but responds to other controls	ESC did not arm because throttle stick and/or throttle trim too high	Lower throttle stick and throttle trim to lowest setting
	Throttle channel is reversed	Reverse throttle channel on transmitter
	Motor disconnected from ESC	Make sure motor is connected to the ESC
	Servo travel set up is less than 100%	Adjust servo travel to 100% or slightly greater
Extra propeller noise or extra vibration	Damaged propeller, prop shaft or motor	Replace damaged parts
	Prop screw is too loose	Tighten the prop screw
	Prop is out of balance	Remove and balance propeller, or replace with a balanced propeller
Reduced flight time or aircraft underpowered	Flight battery charge is low	Completely recharge flight battery
	Propeller installed backwards	Install propeller properly
	Flight battery damaged	Replace flight battery and follow flight battery instructions
	Flight battery is too cold	Make sure battery is warm before use
	Battery capacity too low for flight conditions	Replace battery or use a larger capacity battery
Aircraft will not Bind (during binding) to transmitter	Transmitter too near aircraft during binding process	Power off transmitter, move transmitter a larger distance from aircraft, disconnect and reconnect flight battery to aircraft and follow binding instructions
	Bind switch or button not held long enough during bind process	Power off transmitter and repeat bind process. Hold transmitter bind button or switch until receiver is bound
	Flight battery/Transmitter battery charge is too low	Replace/recharge batteries
	Bind pins on receiver are not correctly connected	Connect receiver bind pins as instructed and bind transmitter to receiver
	Aircraft or transmitter is too close to large metal object, wireless source or another transmitter	Move aircraft and transmitter to another location and attempt binding again
Aircraft will not connect (after binding) to transmitter	Transmitter too close to aircraft during connecting process	Power off transmitter, move transmitter a larger distance from aircraft, disconnect and reconnect flight battery to aircraft
	Flight battery/Transmitter battery charge is too low	Replace/recharge batteries
	Aircraft bound to different model memory (ModelMatch™ radios only)	Select correct model memory on transmitter
	Transmitter may have been bound using different DSM protocol	Bind aircraft to transmitter
	Bind pins on receiver are connected	Ensure bind pins on receiver are not connected
	Aircraft or transmitter is too close to large metal object, wireless source or another transmitter	Move aircraft and transmitter to another location and attempt connecting again
Control surface does not move	Control surface, control horn, linkage or servo damage	Replace or repair damaged parts and adjust controls
	Wire damaged or connections loose	Do a check of wires and connections, connect or replace as needed
	Flight battery charge is low	Fully recharge flight battery
	Control linkage does not move freely	Make sure control linkage moves freely
Controls reversed	Transmitter settings reversed	Adjust controls on transmitter appropriately
Motor power quickly decreases and increases then motor loses power	Battery voltage is down to the point of receiver/ESC Low Voltage Cutoff (LVC)	Recharge flight battery or replace battery that is no longer performing

Limited Warranty

What this Warranty Covers

Horizon Hobby, Inc. ("Horizon") warrants to the original purchaser that the product purchased (the "Product") will be free from defects in materials and workmanship at the date of purchase.

What is Not Covered

This warranty is not transferable and does not cover (i) cosmetic damage, (ii) damage due to acts of God, accident, misuse, abuse, negligence, commercial use, or due to improper use, installation, operation or maintenance, (iii) modification of or to any part of the Product, (iv) attempted service by anyone other than a Horizon Hobby authorized service center, (v) Product not purchased from an authorized Horizon dealer, or (vi) Product not compliant with applicable technical regulations.

OTHER THAN THE EXPRESS WARRANTY ABOVE, HORIZON MAKES NO OTHER WARRANTY OR REPRESENTATION, AND HEREBY DISCLAIMS ANY AND ALL IMPLIED WARRANTIES, INCLUDING, WITHOUT LIMITATION, THE IMPLIED WARRANTIES OF NON-INFRINGEMENT, MERCHANTABILITY AND FITNESS FOR A PARTICULAR PURPOSE. THE PURCHASER ACKNOWLEDGES THAT THEY ALONE HAVE DETERMINED THAT THE PRODUCT WILL SUITABLY MEET THE REQUIREMENTS OF THE PURCHASER'S INTENDED USE.

Purchaser's Remedy

Horizon's sole obligation and purchaser's sole and exclusive remedy shall be that Horizon will, at its option, either (i) service, or (ii) replace, any Product determined by Horizon to be defective. Horizon reserves the right to inspect any and all Product(s) involved in a warranty claim. Service or replacement decisions are at the sole discretion of Horizon. Proof of purchase is required for all warranty claims. SERVICE OR REPLACEMENT AS PROVIDED UNDER THIS WARRANTY IS THE PURCHASER'S SOLE AND EXCLUSIVE REMEDY.

Limitation of Liability

HORIZON SHALL NOT BE LIABLE FOR SPECIAL, INDIRECT, INCIDENTAL OR CONSEQUENTIAL DAMAGES, LOSS OF PROFITS OR PRODUCTION OR COMMERCIAL LOSS IN ANY WAY, REGARDLESS OF WHETHER SUCH CLAIM IS BASED IN CONTRACT, WARRANTY, TORT, NEGLIGENCE, STRICT LIABILITY OR ANY OTHER THEORY OF LIABILITY, EVEN IF HORIZON HAS BEEN ADVISED OF THE POSSIBILITY OF SUCH DAMAGES. Further, in no event shall the liability of Horizon exceed the individual price of the Product on which liability is asserted. As Horizon has no control over use, setup, final assembly, modification or misuse, no liability shall be assumed nor accepted for any resulting damage or injury. By the act of use, setup or assembly, the user accepts all resulting liability. If you as the purchaser or user are not prepared to accept the liability associated with the use of the Product, purchaser is advised to return the Product immediately in new and unused condition to the place of purchase.

Law

These terms are governed by Illinois law (without regard to conflict of law principals). This warranty gives you specific legal rights, and you may also have other rights which vary from state to state. Horizon reserves the right to change or modify this warranty at any time without notice.

WARRANTY SERVICES

Questions, Assistance, and Services

Your local hobby store and/or place of purchase cannot provide warranty support or service. Once assembly, setup or use of the Product has been started, you must contact your local distributor or Horizon directly. This will enable Horizon to better answer your questions and service you in the event that you may need any assistance. For questions or assistance, please visit our website at www.horizonhobby.com, submit a Product Support Inquiry, or call 877.504.0233 toll free to speak to a Product Support representative.

Inspection or Services

If this Product needs to be inspected or serviced and is compliant in the country you live and use the Product in, please use the Horizon Online Service Request submission process found on our website or call Horizon to obtain a Return Merchandise Authorization (RMA) number. Pack the Product securely using a shipping carton. Please note that original boxes may be included, but are not designed to withstand the rigors of shipping without additional protection. Ship via a carrier that provides tracking and insurance for lost or damaged parcels, as Horizon is not responsible for merchandise until it arrives and is accepted at our facility. An Online Service Request is available at http://www.horizonhobby.com/content/_service-center_render-service-center. If you do not have internet access, please contact Horizon Product Support to obtain a RMA number along with instructions for submitting your product for service. When calling Horizon, you will be asked to provide your complete name, street address, email address and phone number where you can be reached during business hours. When sending product into Horizon, please include your RMA number, a list of the included items, and a brief summary of the problem. A copy of your original sales receipt must be included for warranty consideration. Be sure your name, address, and RMA number are clearly written on the outside of the shipping carton.

NOTICE: Do not ship LiPo batteries to Horizon. If you have any issue with a LiPo battery, please contact the appropriate Horizon Product Support office.

Warranty Requirements

For Warranty consideration, you must include your original sales receipt verifying the proof-of-purchase date. Provided warranty conditions have been met, your Product will be serviced or replaced free of charge. Service or replacement decisions are at the sole discretion of Horizon.

Non-Warranty Service

Should your service not be covered by warranty, service will be completed and payment will be required without notification or estimate of the expense unless the expense exceeds 50% of the retail purchase cost. By submitting the item for service you are agreeing to payment of the service without notification. Service estimates are available upon request. You must include this request with your item submitted for service. Non-warranty service estimates will be billed a minimum of ½ hour of labor. In addition you will be billed for return freight. Horizon accepts money orders and cashier's checks, as well as Visa, MasterCard, American Express, and Discover cards. By submitting any item to Horizon

for service, you are agreeing to Horizon's Terms and Conditions found on our website http://www.horizonhobby.com/content/_service-center_render-service-center.

ATTENTION: Horizon service is limited to Product compliant in the country of use and ownership. If received, a non-compliant Product will not be

serviced. Further, the sender will be responsible for arranging return shipment of the un-serviced Product, through a carrier of the sender's choice and at the sender's expense. Horizon will hold non-compliant Product for a period of 60 days from notification, after which it will be discarded.

Warranty and Service Information

Country of Purchase	Horizon Hobby	Address	Phone Number/Email Address
United States of America	Horizon Service Center (Air)	4105 Fieldstone Rd Champaign, Illinois 61822 USA	888-959-2305 Online Repair Request visit: www.horizonhobby.com/service
	Horizon Product Support (All other products)	4105 Fieldstone Rd Champaign, Illinois 61822 USA	877-504-0233 productsupport@horizonhobby.com
United Kingdom	Horizon Hobby Limited	Units 1-4 Ployters Rd Staple Tye Harlow, Essex CM18 7NS, United Kingdom	+44 (0) 1279 641 097 sales@horizonhobby.co.uk
Germany	Horizon Technischer Service	Christian-Junge-Straße 1 25337 Elmshorn, Germany	+49 (0) 4121 2655 100 service@horizonhobby.de
France	Horizon Hobby SAS	11 Rue Georges Charpak 77127 Lieusaint	+33 (0) 1 60 18 34 90 infofrance@horizonhobby.com
China	Horizon Hobby – China	Room 506, No. 97 Changshou Rd. Shanghai, China, 200060	+86 (021) 5180 9868 info@horizonhobby.com.cn

Compliance Information for the European Union

Declaration of Conformity

(in accordance with ISO/IEC 17050-1)
No. HH2013041401

	Product(s):	EFL C-Ray PNP
	Item Number(s):	EFL3075
	Equipment class:	1

The object of declaration described above is in conformity with the requirements of the specifications listed below, following the provisions of the European EMC Directive 2004/108/EC:

EN55022:2010 + AC:2011
EN55024:2010

Signed for and on behalf of:
Horizon Hobby, Inc.
Champaign, IL USA
Apr 14, 2013

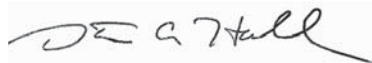

Steven A. Hall
Executive VP – Chief Operating Officer
International Operations and Risk Management
Horizon Hobby, Inc.

Instructions for disposal of WEEE by users in the European Union



This product must not be disposed of with other waste. Instead, it is the user's responsibility to dispose of their waste equipment by handing it over to a designated collections point for the recycling of waste electrical and electronic equipment. The separate collection and recycling of your waste equipment at the time of disposal will help to conserve natural resources and ensure that it is recycled in a manner that protects human health and the environment. For more information about where you can drop off your waste equipment for recycling, please contact your local city office, your household waste disposal service or where you purchased the product.

Replacement Parts – Ersatzteile – – Pièces de rechange – Recapiti per i ricambi –

Part # • Nummer Numéro • Codice	Description	Beschreibung	Description	Descrizione
EFL307501	Replacement Airframe: C-Ray 180	E-flite C-Ray 180: Ersatzrumpf	Structure de remplacement : C-Ray 180	Ricambio cellula: C-Ray 180
EFL307502	Hatch: C-Ray 180	E-flite C-Ray 180: Kabinenhaube	Verrière : C-Ray 180	Portello: C-Ray 180
EFL307503	Motor Mount & Hardware: C-Ray 180	E-flite C-Ray 180: Motorträger m. Zbh	Support moteur avec visserie : C-Ray 180	Supporto motore e viteria: C-Ray 180
EFL307504	Decal Sheet: C-Ray 180	E-flite C-Ray 180: Dekorbogen	Planche de décoration : C-Ray 180	Foglio adesivi: C-Ray 180
EFLM7005	180 Brushless Outrunner Motor, 2500Kv: C-Ray 180	E-flite C-Ray: 180 Brushless Aussenläufer	Moteur brushless 180 à cage tournante 2500Kv : C-Ray 180	Motore brushless 180 a cassa rotante: C-Ray 180
EFLM700501	180 Motor Outer Housing and Shaft, 2500Kv: C-Ray 180	E-flite C-Ray: 180 Motor 2500 KV Motorgehäuse und Welle	Cloche et axe pour BL180 2500Kv : C-Ray 180	Carcassa motore 180 e albero: C-Ray 180
EFLA7200	8-Amp Brushless ESC	E-flite 8-Amp Brushless ESC	Contrôleur brushless 8A	Regolatore (ESC) brushless 8A
EFLR7105	3-Gram Super Sub-Micro Servo	E-flite 3-Gram Super Sub-Micro Servo	Super-sub-micro servo 3g	Servo super sub-micro 3 grammi
EFLM1933A	Prop Adapter with Setscrew, 1.5mm	E-flite Prop Adapter m. Schraube 1.5mm	Adaptateur d'hélice, avec vis , 1.5mm	Adattatore elica con grano, 1.5mm
EFLP4540E	4.5 x 4 Electric Propeller	E-flite 4.5 x 4 Elektro Propeller	Adaptateur d'hélice, avec vis , 1.5mm	Elica per elettrico 4,5x4

– Optional Parts and Accessories –
– Optionale Bauteile und Zubehörteile –
– Pièces optionnelles et accessoires –
– Parti opzionali e accessori –

Part # • Nummer Numéro • Codice	Description	Beschreibung	Description	Descrizione
EFLB4502SJ30	450mAh 2S 7.4V 30C Li-Po, 20AWG JST	450mAh 2S 7.4V 30C Li-Po, 20AWG JST	Batterie Li-Po 7.4V 2S 450mA 30C	450mAh 2S 7.4V 30C Li-Po, 20AWG JST
SPMAR6310	AR6310 DSMX Nanolite 6-Channel Receiver, Air	Spektrum 6 Kanal Nanolite Empfänger DSMX	Récepteur AR6310 DSMX Nanolite 6 voies	AR6310 DSMX Nanolite ricevitore 6 canali, Air
EFLA230	Charger Lead with JST Female	E-flite Ladekabel m/ JST Buchse	Câble de charge avec prise JST femelle	Cavo di carica con femmina JST
EFLA250	Park Flyer Tool Assortment, 5 pc	Park Flyer Werkzeugsortiment, 5 teilig	Assortiment d'outils park flyer, 5pc	Park Flyer assortimento attrezzi, 5 pc
EFLB4302SJ	430mAh 2S 7.4V 20C Li-Po, 20AWG JST	E-flite 430mAh 2S 20C Lipo JST	Batterie Li-Po 7.4V 2S 430mA 20C	430mAh 2S 7.4V 20C Li-Po, 20AWG JST
EFLC3025	Celectra 80W AC/DC Multi-Chemistry Battery Charger	E-flite 80W AC/DC Multi-Akku Ladegerät - EU	Chargeur Celectra 80W AC/DC	Celectra 80W AC/DC Carica batterie multiplo
EFLA110	Power Meter	E-flite Lastmessgerät	Multimètre E-flite	Misuratore di potenza
	DX6i DSMX 6-Channel Transmitter	DX6i DSMX 6-Kanal Sender	Emetteur DX6i DSMX 6 voies	DX6i DSMX Trasmettitore 6 canali
	DX7s DSMX 7-Channel Transmitter	Spektrum DX7s 7 Kanal Sender	Emetteur DX7s DSMX 7 voies	DX7s DSMX Trasmettitore 7 canali
	DX8 DSMX Transmitter	Spektrum DX8 nur Sender	Emetteur DX8 DSMX 8 voies	DX8 DSMX trasmettitore 8 canali
	DX18 DSMX Transmitter	Spektrum DX18 nur Sender	Emetteur DX18 DSMX 18 voies	DX18 DSMX trasmettitore 18 canali

– Parts Contact Information –
– Kontaktinformationen für Ersatzteile –
– Coordonnées pour obtenir des pièces détachées –
– Recapiti dei distributori –

Country of Purchase	Horizon Hobby	Address	Phone Number/Email Address
United States	Sales	4105 Fieldstone Rd Champaign, Illinois, 61822 USA	888-959-2305 sales@horizonhobby.com
United Kingdom	Horizon Hobby Limited	Units 1-4 Ployters Rd Staple Tye Harlow, Essex CM18 7NS, United Kingdom	+44 (0) 1279 641 097 sales@horizonhobby.co.uk
Germany	Horizon Hobby GmbH	Christian-Junge-Straße 1 25337 Elmshorn, Germany	+49 (0) 4121 2655 100 service@horizonhobby.de
France	Horizon Hobby SAS	11 Rue Georges Charpak 77127 Lieusaint, France	+33 (0) 1 60 18 34 90 infofrance@horizonhobby.com
China	Horizon Hobby – China	Room 506, No. 97 Changshou Rd. Shanghai, China, 200060	+86 (021) 5180 9868 info@horizonhobby.com.cn

© 2013 Horizon Hobby, Inc.

E-flite, Z-Foam, C-Ray, DSM, DSM2, DSMX, Celectra, JR, ModelMatch, Plug-N-Play and the Horizon Hobby logo are trademarks or registered trademarks of Horizon Hobby, Inc.

The Spektrum trademark is used with permission of Bachmann Industries, Inc.

Patents pending.
www.e-fliterc.com

