



ESTES INDUSTRIES
1295 H STREET
PENROSE, CO 81240 USA

BETA
SERIES

BIG BERTHA™

FLYING MODEL ROCKET KIT

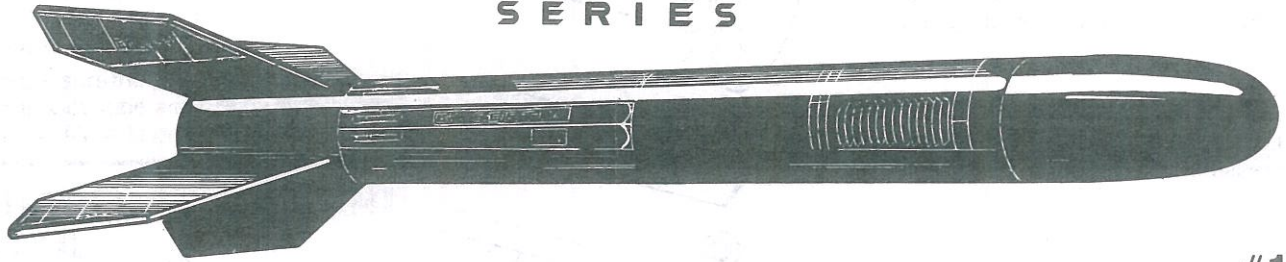

#1948

HOW TO USE THESE INSTRUCTIONS:

READ ALL INSTRUCTIONS BEFORE STARTING WORK ON THIS MODEL

- A. This rocket, incorporating basic model rocketry construction techniques, will help you in the development of your rocketry modeling skills.
- B. Read each step first and visualize the procedure thoroughly in your mind before starting construction.
- C. Lay parts out on the table in front of you. (Check inside tubes for any small parts.)
- D. Use exploded view to match all parts contained in kit.
- E. Collect all construction supplies that are not included in the kit.
- F. The tube marking guide and shock cord mount are printed in the instructions and will be found on page 5.
- G. Test fit parts before applying any glue.
- H. Sand parts as necessary for proper fit.
- I. The construction supplies required for each step are listed at the beginning of each step.
- J. Check off each step as you complete it.

EXPLODED VIEW

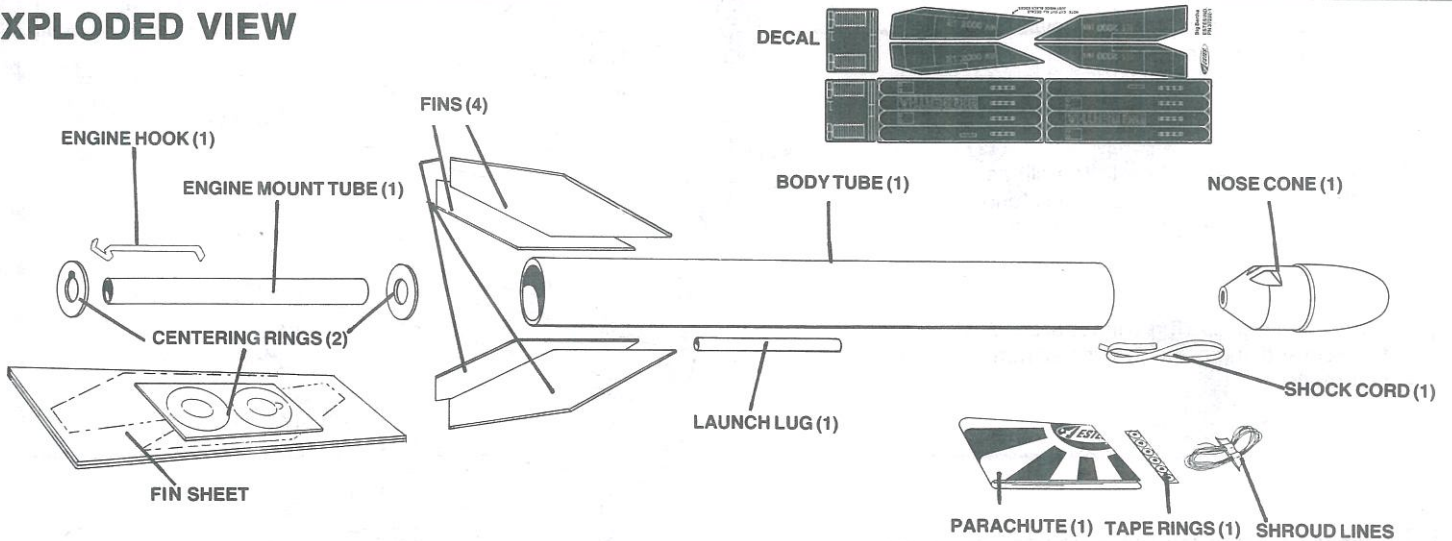

SHOCK CORD MOUNT & TUBE MARKING GUIDE LOCATED ON PAGE 5

EXTREMELY IMPORTANT: THE EXPLODED VIEW IS FOR REFERENCE ONLY! DO NOT USE THIS DRAWING ALONE TO ASSEMBLE THIS MODEL.

The exploded view is only intended to assist you in locating the parts included in this kit. Refer back to this exploded view as you build your model step by step. This method will help you to put the parts into perspective as you progress through the construction.

CONSTRUCTION SUPPLIES

In addition to the parts included in your kit, you will need these construction supplies. Each step shows which supplies will be required.



PENCIL



HOBBY KNIFE



MASKING TAPE



WOOD GLUE
(white or yellow)



SCISSORS



SANDPAPER



SANDING SEALER



SPRAY PAINT
(Black)

GLUE IS APPLIED TO SURFACES SHOWN IN RED.

1. ENGINE MOUNT ASSEMBLY



- A. You will need the engine mount tube, engine hook and two centering rings.
- B. Locate the ruler printed in the center crease of this instruction sheet.
- C. Lay one end of the engine mount tube on the zero mark of the ruler.
- D. Take your pencil and place four marks on the engine mount tube at 6 mm (1/4"), 25 mm (1"), 64 mm (2 1/2") and 216 mm (8 1/2") from zero.
- E. Cut a 3 mm (1/8") wide slit as shown at the 64 mm (2 1/2") mark only.
- F. Insert the engine hook into the slit as shown. The engine hook should extend beyond the rear of the engine tube.
- G. Wrap masking tape three times around the tube and engine hook at the 25 mm (1") mark.
- H. Carefully remove the centering rings from their card. Use a knife to finish cuts.
- I. Slide the notched centering ring 6 mm (1/4") onto the rear of the engine mount tube with the notch over the engine hook. Slide the remaining centering ring over the front of the engine mount tube down to the 216 mm (8 1/2") mark you made in step D.
- J. Once the rings are in place, apply glue to both sides of the rings. Set assembly aside and allow to dry.

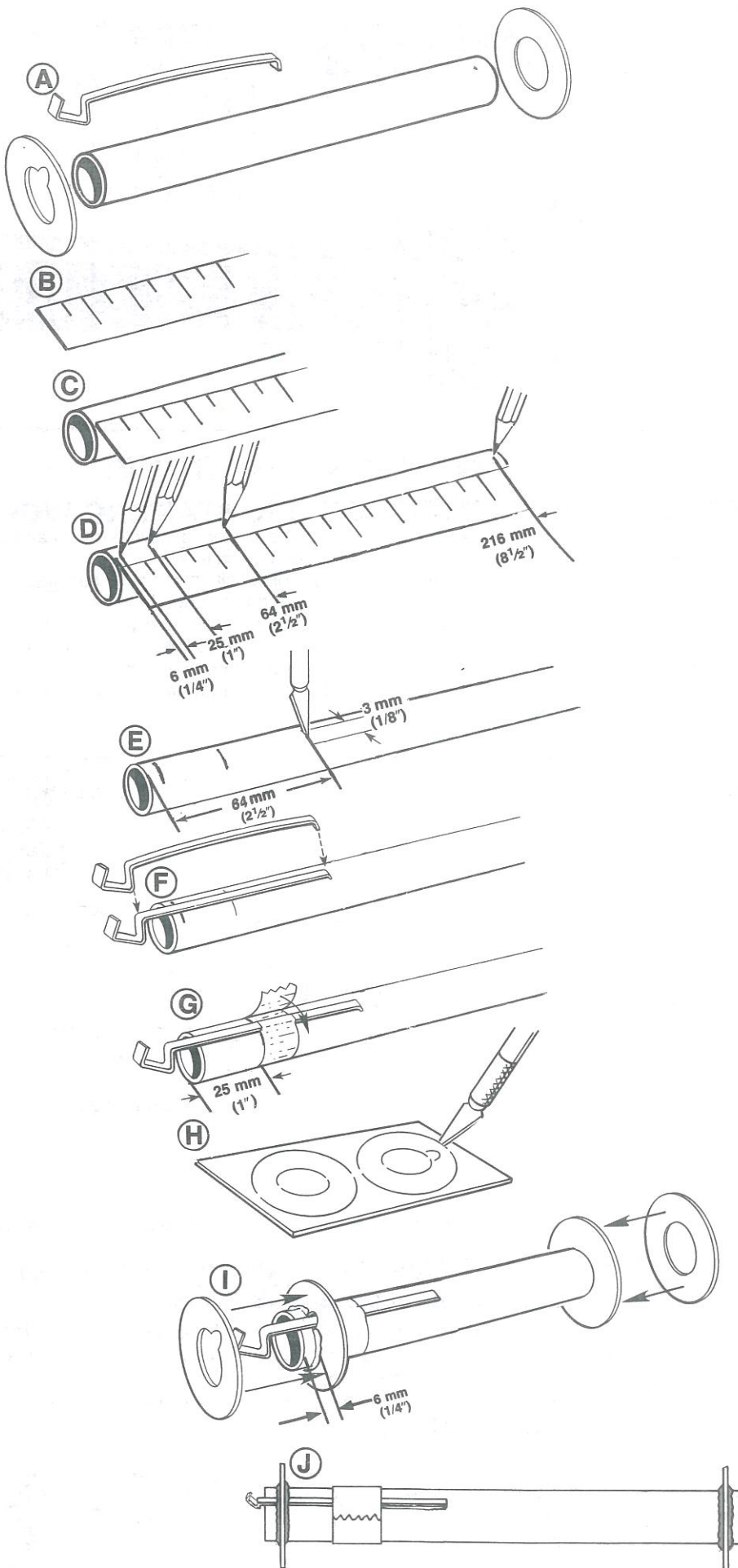

2. SHOCK CORD MOUNT ASSEMBLY



- A. Locate the shock cord mount on the bottom of page 5 in the patterns section.
- B. Cut out the shock cord mount along the solid black outline.
- C. Crease on dotted lines by folding.
- D. Spread glue on section 2 and lay end of shock cord into glue at a slight diagonal as shown.
- E. Fold section 1 forward. Apply glue to section 3. Fold forward again.
- F. Clamp firmly with your fingers for 2 minutes until glue dries. Set aside until step 9.

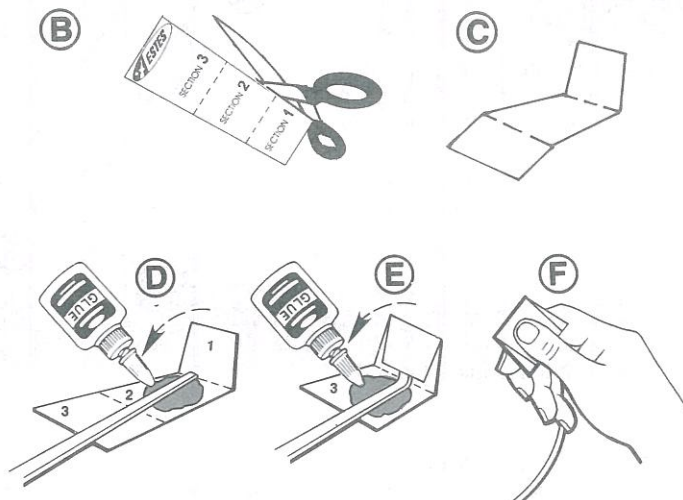

3. FIN PREPARATION



NOTE: Read before proceeding with this step.

- Since your fins are not completely cut out of the balsa sheet stock, you will need to **work carefully** with your hobby knife to free the fins from the sheet.
- Be sure to cut completely around each fin outline before attempting to remove fins from the sheet.
- Check both sides of the sheet to make sure you cut through.
- Pay close attention to the corner areas where die cutting is not complete.
- As you cut around each fin, cut away from adjacent fins so you will not damage the other fins on the sheet.

- A. Free the fins from both balsa sheets with your hobby knife.
- B. Keep a piece of scrap balsa to use as a glue applicator in step 4.
- C. Lay sandpaper, rough face up, on your table. Stack the fins together and lightly sand the edges smooth and flat.
HINT: To replace damaged fins, trace fins onto a sheet of paper and save it with your instructions.

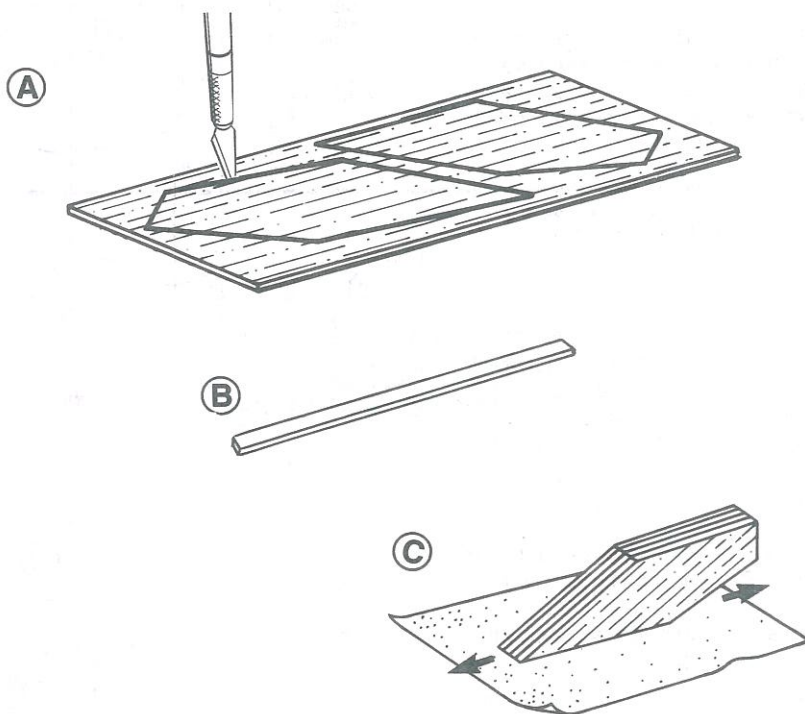

4. ENGINE MOUNT INSTALLATION



- A. Locate the body tube.
- B. Slide the front end of the engine mount assembly part way into the body tube.
- C. Using the scrap balsa glue applicator, spread glue around the inside rear end of the body tube.
- D. Continue to push the engine mount assembly into the body tube until the end of the engine mount tube is even with the end of the body tube.
- E. Make a glue reinforcement joint between the body tube and rear centering ring.

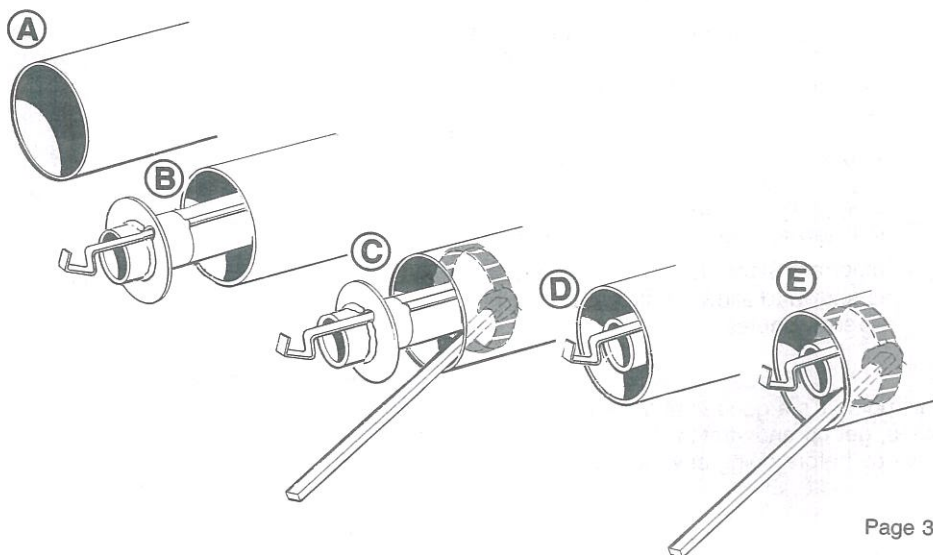

5. TUBE MARKING DETAIL



NOTE: It will be easier to attach the fins if the body tube is slightly roughened by sanding with #600 grit sandpaper. Sand before marking body tube.

- A. Locate the tube marking guide on the bottom of page 5 in the patterns section. Cut the guide along the outline.
- B. Wrap the guide around the body tube and tape it in place (this is the same end that contains the engine mount).
- C. Mark tube at all arrow locations. One line on your tube marking guide is labeled LL, this means launch lug. Write LL on the body tube for that line. Remove marking guide.
- D. Using a door frame as a guide, draw straight lines connecting each pair of fin marks. Extend these lines 127 mm (5") along the tube. Draw a line the full length of the tube for the launch lug.

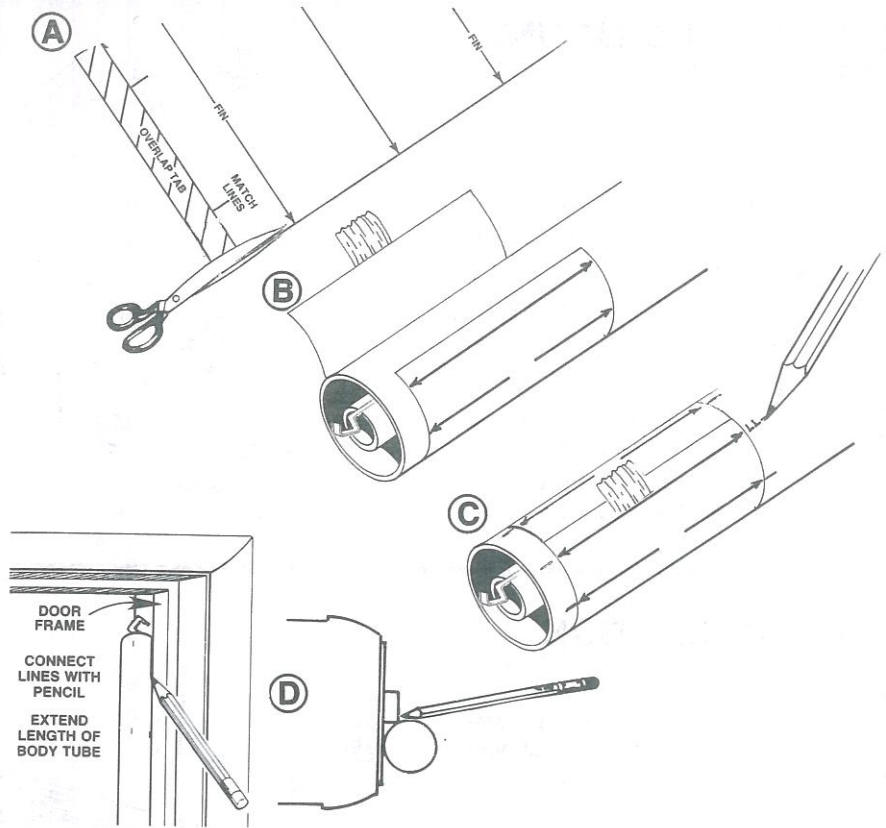

6. FIN ATTACHMENT



NOTE: Before gluing your fins, identify the root edge that will be glued to the body tube and the front (leading) edge. (The leading edge always parallels the grain of the wood for extra fin strength.) This will help you attach your fins correctly. **Remember:** Fins must be attached correctly for stable flights.

- A. Apply a thin film of glue to the root edge of one fin. Allow it to dry for a minute or two.
- B. Apply a second thin film of glue to the root edge of the same fin.
- C. Set the rear edge of the fin even with the rear of the body tube and gently press the root edge along the body tube fin line.
- D. Carefully adjust the fin, if needed, so it will project straight up from body tube as shown. Work slowly and carefully so as not to disturb the glue joint. Attach remaining fins in same manner. Hold the fin upright. Do not set the rocket on its fins while glue is still wet.
- E. After all fins are attached, use shaded end view to check proper fin spacing.
- F. Important: Stand the rocket on the table as shown to allow the fins to dry for several minutes.

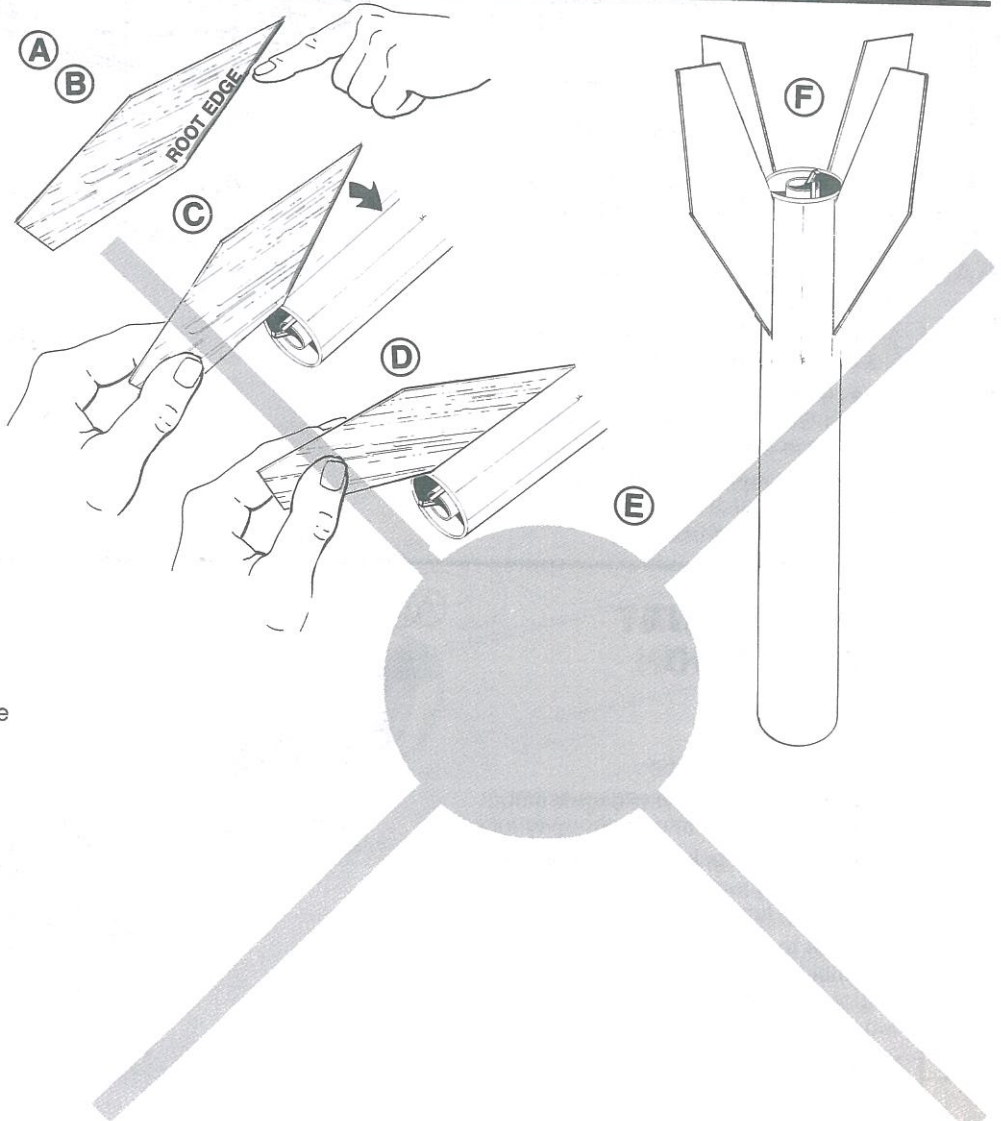

At this point, it's a good idea to rest for a few minutes, get up and stretch or read through the next steps before doing any more work.

7. LAUNCH LUG ATTACHMENT



- A. Apply glue to the launch lug and attach it to the body tube on the launch lug line with its rear edge even with the front tips of the fins.
- B. Make sure the launch lug is aligned with the body tube as shown on the end view. Allow to dry.

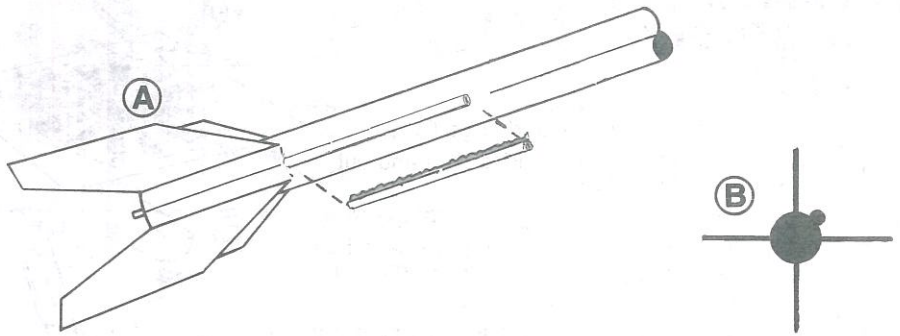

8. GLUE REINFORCEMENT DETAIL



NOTE: Glue joint reinforcements or fillets are important because they help blend the fins, launch lugs or other components into the body tube. This blending improves the looks of your model, allows smoother air flow over your rocket during flight and strengthens the attachment points.

- A. Reinforce each fin/body tube joint with glue and each side of launch lug as shown. Use your finger to help smooth the glue fillet.
- B. Stand rocket on table as shown to allow glue to dry for approximately five minutes. Wipe away any excess glue that may run down the side of the body tube. Allow to dry.

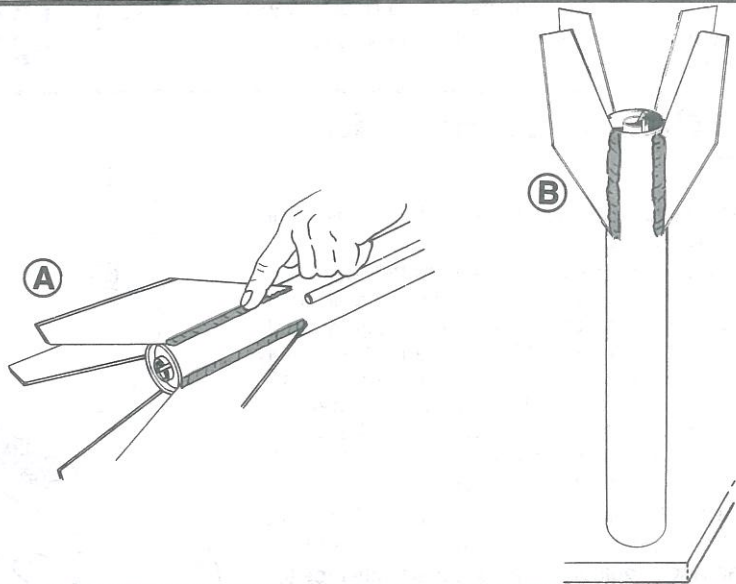

9. SHOCK CORD MOUNT ATTACHMENT



- A. Measure approximately 25 mm (1") from the front end of the body tube.
- B. Apply glue to shock cord mount and insert into tube.
- C. Set the mount back at least 25 mm (1") to allow for nose cone clearance and press mount firmly into glue as shown.
- D. Hold until glue sets.

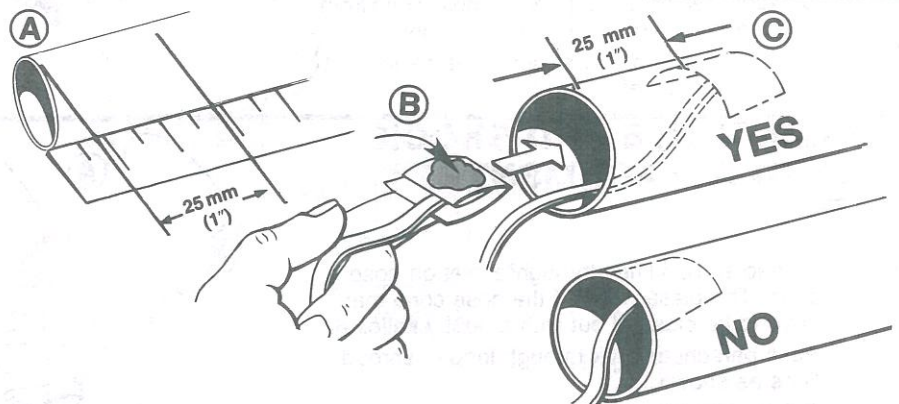

PATTERNS SECTION

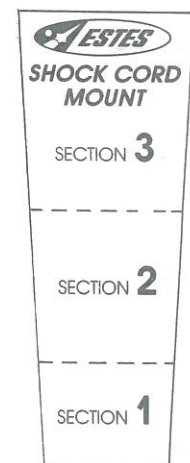
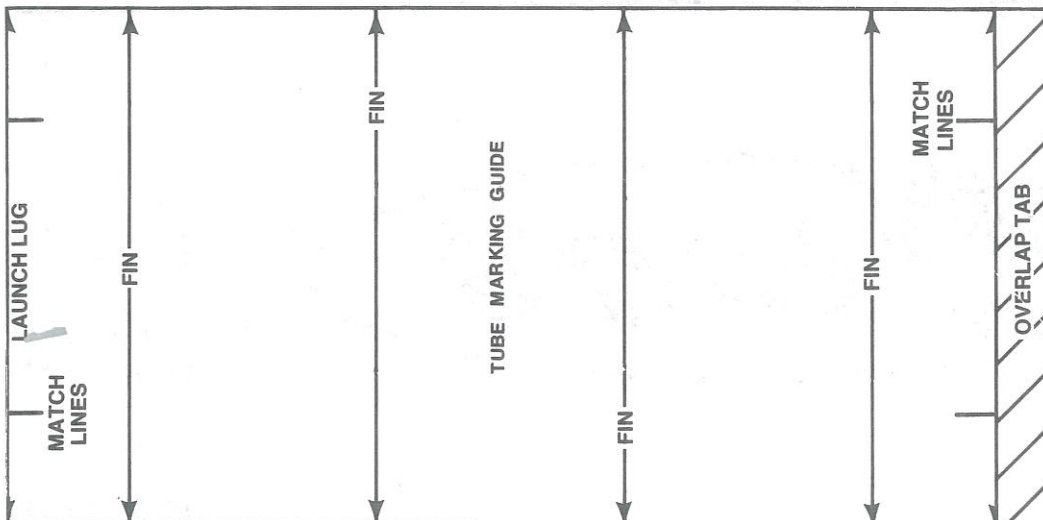

10. PARACHUTE ASSEMBLY



- A. Cut out parachute on printed edge lines.
- B. Remove tape from shroud lines, fold and cut into three equal lengths.
- C. Attach tape rings to top of parachute and press firmly into place. Punch hole through the parachute material with the point of a sharp pencil. (Do not use a dull pencil or ballpoint pen.)
- D. Pass shroud line through hole in parachute and tape ring. Tie lines together with a double knot.
- E. Attach remaining lines to other corners to complete parachute.

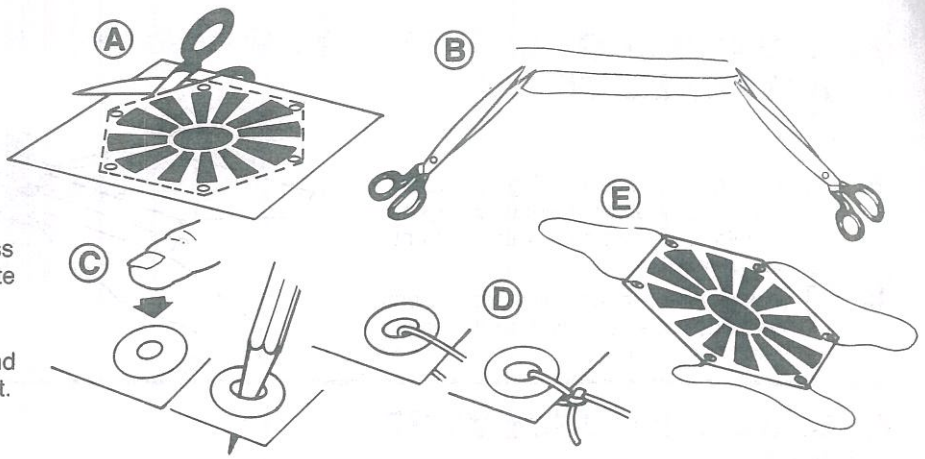

11. PAINTING YOUR ROCKET



- A. Before you paint your rocket, make sure all of the glue joints are completely dry.
- B. Optional: For a smoother and better-looking finish, spray a coat of automotive primer on your rocket. Do not apply too much. Lightly sand the rocket with a 400 to 600 grit sandpaper. Apply another coat if needed. Sand between coats. The primer will allow the final coats of paint to adhere better to the rocket. Several light mist coats of paint are preferable. Too much paint will add to the rocket's weight.
- C. Refer to the illustration on the front of the color panel for paint locations and decal placement.
- D. Mask the shoulder of the nose cone with tape to prevent overspray. Suspend the nose cone from a string and paint it black. Allow to dry.
- E. Paint body as shown. Use spray enamel to paint your model rocket.

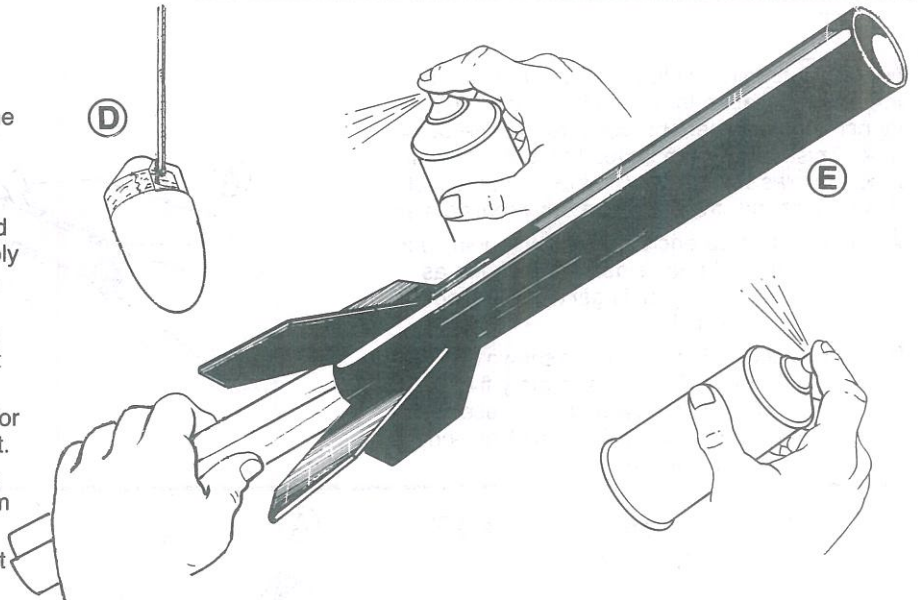

12. PARACHUTE AND SHOCK CORD ATTACHMENT



- A. Thread shroud lines through eyelet on nose cone. The plastic loop of the nose cone may have to be cleaned out with a hobby knife.
- B. Pass parachute back through loop of shroud lines as shown.
- C. Pull lines tight.
- D. Tie free end of shock cord to nose cone. Use a double knot.

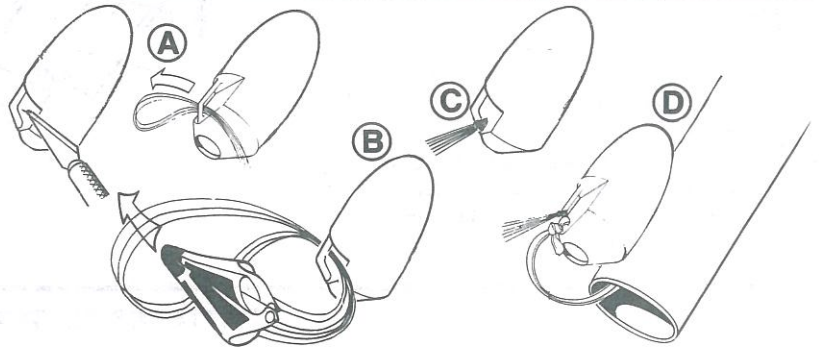

ROCKET PREFLIGHT

CRUMPLE AND INSERT 6 SQUARES OF RECOVERY WADDING

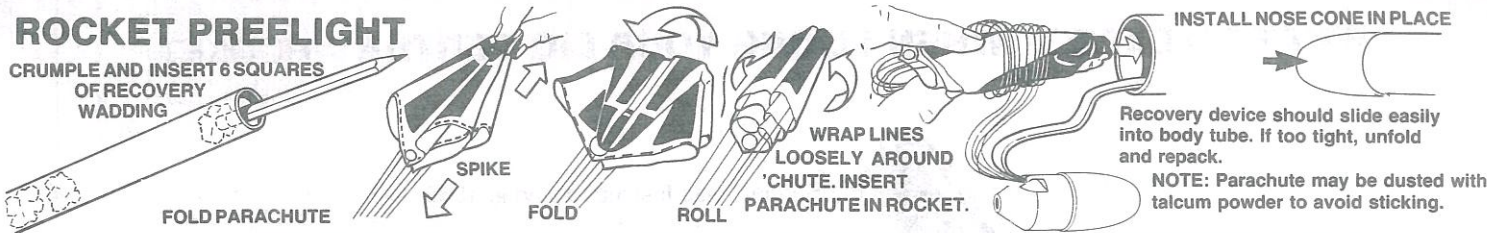

FOLD PARACHUTE

SPIKE

FOLD

ROLL

WRAP LINES LOOSELY AROUND CHUTE. INSERT PARACHUTE IN ROCKET.

INSTALL NOSE CONE IN PLACE

Recovery device should slide easily into body tube. If too tight, unfold and repack.

NOTE: Parachute may be dusted with talcum powder to avoid sticking.

PREPARE ENGINE

NOTE: Igniter plugs come with rocket engines. If your engines did not come with plugs, follow the instructions that came with the engines.



SEPARATE IGNITER AND IGNITER PLUG



HOLD ENGINE UPRIGHT, DROP IN IGNITER

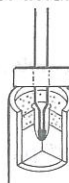

IGNITER MUST TOUCH PROPELLANT



INSERT IGNITER PLUG

FIRMLY PUSH ALL THE WAY IN



BEND IGNITER WIRES BACK

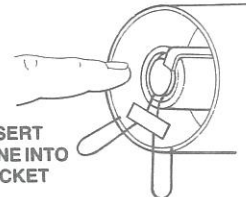

INSERT ENGINE INTO ROCKET

LAUNCH SUPPLIES

To launch your rocket you will need the following items:

- Estes Electrical Launch Controller and Launch Pad
 - Estes Recovery Wadding No. 2274
 - Recommended Estes Engines: A8-3, B4-2, B6-4, B6-2 (First Flight), B6-4, B8-5 or C6-5
- To become familiar with your rocket's flight pattern, use a B6-2 engine for your first flight. Use only Estes products to launch this rocket.

FLYING YOUR ROCKET

Choose a large field away from power lines, tall trees, and low flying aircraft. Try to find a field at least 76 meters (250 feet) square. The larger the launch area, the better your chance of recovering your rocket. Football fields and playgrounds are great.

Launch area must be free of dry weeds and brown grass.

Launch only during calm weather with little or no wind and good visibility.

Don't leave parachute packed more than a minute or so before launch during cold weather [colder than 4° Celsius (40° Fahrenheit)].

Parachute may be dusted with talcum powder to avoid sticking.

MISFIRES

If the igniter functions properly but the propellant does not ignite, keep in mind the following: An Estes igniter will function properly even if the coated tip is chipped. However, if the coated tip is not in direct contact with the engine propellant, it will only heat and not ignite the engine.

When an ignition failure occurs, remove the safety key from the launch control system and wait one minute before approaching the rocket. Remove the expended igniter from the engine and install a new one. Be certain the coated tip is in direct contact with the engine propellant, then reinstall the igniter plug as illustrated above. Repeat the countdown and launch procedure.

FOR YOUR SAFETY AND ENJOYMENT

Always follow the NAR* MODEL ROCKETRY SAFETY CODE while participating in any model rocketry activities.

*National Association of Rocketry

MICRO-CLIPS MUST NOT TOUCH BLAST DEFLECTOR OR EACH OTHER

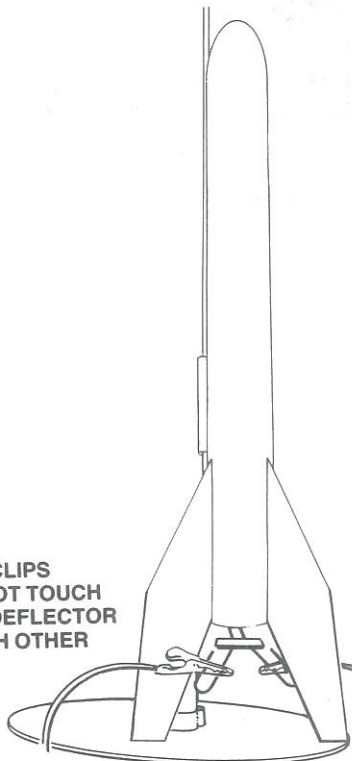

SAFETY KEY MUST NOT BE IN LAUNCH CONTROLLER WHEN ATTACHING MICRO-CLIPS TO ENGINE IGNITERS

COUNTDOWN AND LAUNCH

- ⑩ BE CERTAIN SAFETY KEY IS NOT IN LAUNCH CONTROLLER.
- ⑨ Remove safety cap and slide launch lug over launch rod to place rocket on launch pad. Make sure the rocket slides freely on the launch rod.
- ⑧ Attach micro-clips to the igniter wires. Arrange the clips so they do not touch each other or the metal blast deflector. Attach clips as close to protective tape on igniter as possible.
- ⑦ Move back from your rocket as far as launch wire will permit (at least 5 meters-15 feet).
- ⑥ INSERT SAFETY KEY to arm the launch controller. Give audible countdown-5...4...3...2...1

LAUNCH!!

PUSH AND HOLD LAUNCH BUTTON UNTIL ENGINE IGNITES

REMOVE SAFETY KEY FROM LAUNCH CONTROLLER. REPLACE SAFETY KEY AND SAFETY CAP ON LAUNCH ROD.

If you use the ultrasafe E2™ or Command™ Launch Controllers to fly your models, use the following launch steps.

- A. After attaching micro-clips, etc., insert the safety key into the controller receptacle. If the igniter clips have been attached properly to the igniter, the red L.E.D. will now begin to flash on and off and the audio continuity indicator will beep on and off.
- B. Hold the yellow (left) arm button down. The L.E.D. will stop flashing and the audio indicator will produce a steady tone.
- C. Verbally count down from five to zero loud enough for the bystanders to hear. Still holding the yellow arm button down, push and hold the orange (right) button down until the rocket ignites and lifts off.

WHAT TO EXPECT WHEN FLYING YOUR BIG BERTHA™ ROCKET

Big Bertha™ was first introduced in 1965.

Even with a powerful C6-5 engine, this rocket can be flown on a baseball field.

Estimated altitude is 168 meters (550 feet).

At apogee, the big 45 cm (18") parachute is ejected and Big Bertha™ drifts slowly back to Earth.

Big Bertha™ has a tendency to tilt into the breeze (weathercock) when flying.

If so, the breeze will carry it back, so keeping your eye on Big Bertha™ is fun and easy.

