

HANGAR 9

P-47 Thunderbolt

ASSEMBLY MANUAL



Specifications

Wingspan:	65" / 165.1 cm	Weight:	8–9 lbs (3.5–4.1 kg)
Wing area:	727.5 sq in / 4693.5 sq cm	Recommended engine:.....	.60–1.00 2-stroke
Fuselage length:	51.18" / 130 cm	72–1.00 4-stroke
		Radio:	5-channel w/6 servos

Table of Contents

Contents of Kit	3
Required Radio and Engine.	3
Additional Required Tools and Adhesives.	4
Warning	4
Covering Colors	4
Before Starting Assembly	5
Using the Manual	5
Warranty Information	5
Section 1: Joining the Wing Halves	6
Section 2: Attaching the Wing.	9
Section 3: Installing the Horizontal Stabilizer	10
Section 4: Installing the Vertical Stabilizer	12
Section 5: Installing the Ailerons	14
Section 6: Installing the Elevators.	16
Section 7: Rudder Installation.	17
Section 8: Retract Linkage Installation	18
Section 9: Four-Stroke Engine Installation	21
Section 10: Two-Stroke Engine Installation.	23
Section 11: Fuel Tank Installation	25
Section 12: Radio Installation	26
Section 13: Linkage Installation	30
Section 14: Cowling Installation	33
Section 15: Canopy and Decal Installation	35
Adjusting the Engine.	36
Preflight	36
Control Throws.	37
Recommended CG	37
Range Testing the Radio	37
2005 Official AMA National Model Aircraft Safety Code	38

Contents of Kit

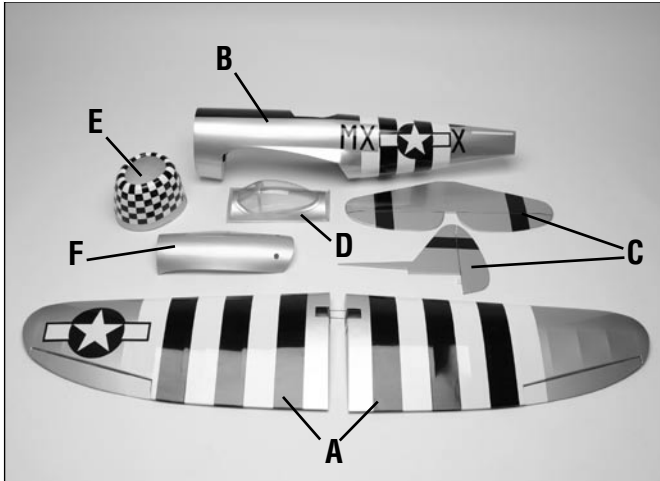

Large Parts:

A. Wing Set	HAN2976
B. Fuselage	HAN2977
C. Tail Set	HAN2978
D. Painted Canopy	HAN2981
E. Cowling	HAN2979
F. Fiberglass Belly Pan	HAN2985

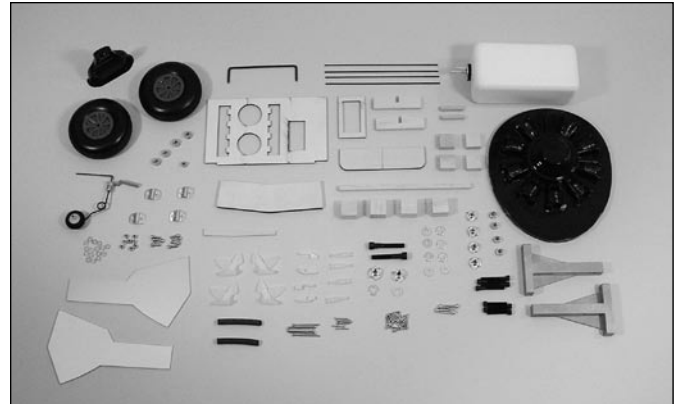

Small Parts:

1. 3 1/4" Wheels	HAN2385
2. Fuel Tank	HAN1987
3. Engine Mount	HAN2033
4. Tailwheel Assembly	HAN2980

Items Not Shown:

Plastic Wheel Wells	HAN2984
P-47 Mechanical Retracts	HAN2983
Decal Set	HAN2987
Pushrod Set	HAN2986
Cockpit Detail	HAN2982

Required Radio and Engine

Radio Equipment

- 5-channel radio system (minimum)
- 5 standard servos (JRPS537 recommended or equivalent)
- Low-Profile Retract Servo (JRPS791)
- 12" Servo Extension (JRPA098) (2)
- 18" Servo Extension (JRPA099) (2)
- Large Servo Arms w/Screw (JRPA212)
- Radio Switch (JRPA003)
- 900mAh receiver battery (minimum)

Recommended Engines

- .61 2-stroke
- 1.00 4-stroke



Evolution .61NT
EVOE0610

Recommended JR® Systems

- XF421EX
- XP6102
- XP662
- X-378
- XP9303
- 10X

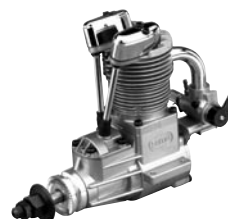

Saito 1.00 FA-AAC
SAIE100



JR XF631



JR XP9303

Additional Required Tools and Adhesives

Tools

- Hobby scissors
- Drill
- Drill bits: 1/16", 5/64", 3/32", 1/8", 9/64", 5/32", 1/4"
- Felt-tipped pen
- Flat blade screwdriver
- Foam: 1/4"
- Hex wrench: 9/64", 3/16"
- Hobby knife
- Phillips screwdriver (small)
- Pliers
- Sandpaper
- Socket wrench: 11/32"
- Square
- T-pins

Adhesives

- 6-Minute Epoxy (HAN8000)
- 30-Minute Epoxy (HAN8002)
- Thin CA (PAAPT07)
- Medium CA (PAAPT01)
- CA Remover/Debonder (PAAPT16)
- Masking Tape (MMM20901)
- Canopy glue (Formula 560)

Other Required Items

- Epoxy Brushes (DUB345)
- Fuel tubing
- Mixing Sticks for Epoxy (DUB346)
- Paper towels
- Rotary tool w/sanding drum
- Rubbing alcohol
- Ruler
- String
- Wax paper

Warning

An RC aircraft is not a toy! If misused, it can cause serious bodily harm and damage to property. Fly only in open areas, preferably at AMA (Academy of Model Aeronautics) approved flying sites, following all instructions included with your radio and engine.

Covering Colors

- | | | | |
|---------|---------|----------|---------|
| • Black | HANU870 | • Silver | HANU881 |
| • White | HANU874 | | |

Before Starting Assembly

Before beginning the assembly of the P-47, remove each part from its bag for inspection. Closely inspect the fuselage, wing panels, rudder, and stabilizer for damage. If you find any damaged or missing parts, contact the place of purchase.

If you find any wrinkles in the covering, use a heat gun or covering iron to remove them. Use caution while working around areas where the colors overlap to prevent separating the colors.



HAN100 – Heat Gun

HAN150 – Covering Glove



HAN101 – Covering Iron

**HAN141 – Sealing Iron
Sock**

Using the Manual

This manual is divided into sections to help make assembly easier to understand and to provide breaks between each major section. In addition, check boxes have been placed next to each step to keep track of them as they're completed. Steps with two boxes indicate that the step will require repeating, such as for a right or left wing panel, two servos, etc. Remember to take your time and follow the directions.

Warranty Information

Horizon Hobby, Inc. guarantees this kit to be free from defects in both material and workmanship at the date of purchase. This warranty does not cover any parts damaged by use or modification. In no case shall Horizon Hobby's liability exceed the original cost of the purchased kit. Further, Horizon Hobby reserves the right to change or modify this warranty without notice.

In that Horizon Hobby has no control over the final assembly or material used for the final assembly, no liability shall be assumed nor accepted for any damage of the final user-assembled product. By the act of using the product, the user accepts all resulting liability.

Once assembly of the model has been started, you must contact Horizon Hobby, Inc. directly regarding any warranty question that you have. Please do not contact your local hobby shop regarding warranty issues, even if that is where you purchased it. This will enable Horizon to better answer your questions and provide service in the event that you may need any assistance.

If the buyer is not prepared to accept the liability associated with the use of this product, the buyer is advised to return this kit immediately in new and unused condition to the place of purchase.

Horizon Hobby Service Department
4105 Fieldstone Road
Champaign, Illinois 61822
(217) 355-9511
horizonhobby.com

Section 1: Joining the Wing Halves

Required Parts

- Left and right wing panels
- Center wing panel
- Wing joiner
- Wing dowels (2)

Required Tools and Adhesives

- Masking tape
- 30-minute epoxy
- Epoxy brush
- Mixing stick
- Rubbing alcohol
- Paper towels

□ Step 1

Draw a centerline on the wing joiner as shown.

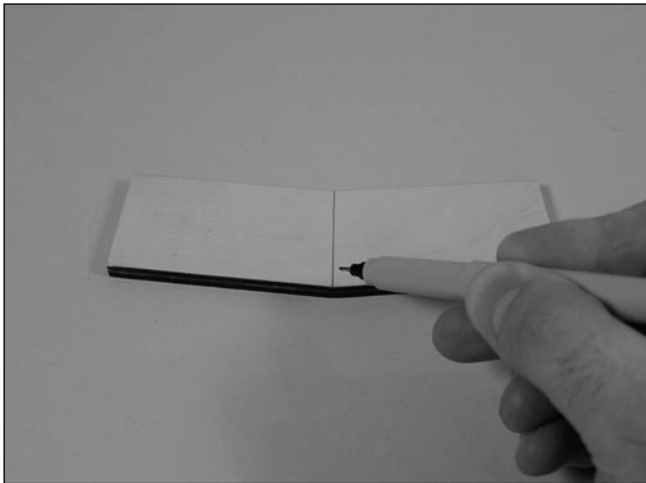

□ Step 2

Test the fit of the wing joiner into one of the wing panels. The joiner should slide into the panel with little resistance up to the line drawn on the joiner. Lightly sand the joiner as necessary to achieve a proper fit.

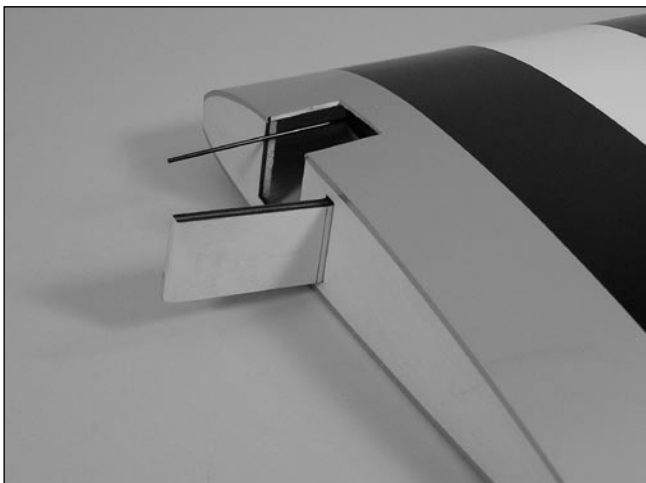

Note: The joiner will be angled towards the top of the wing.

□ Step 3

Test the fit of the wing joiner into the remaining wing panel. The joiner should again slide into the panel with little resistance up to the line drawn on the joiner. Lightly sand the joiner as necessary to achieve a proper fit.

□ Step 4

Remove the covering in the leading edge for the wing dowels. Locate a $1/4" \times 1\frac{3}{16}"$ wing dowel. Use 30-minute epoxy to glue the wing dowels into the wing panels. The dowels should be inserted so $3/8"$ of the dowel is left exposed in front of the leading edge. Repeat for both wing dowels.

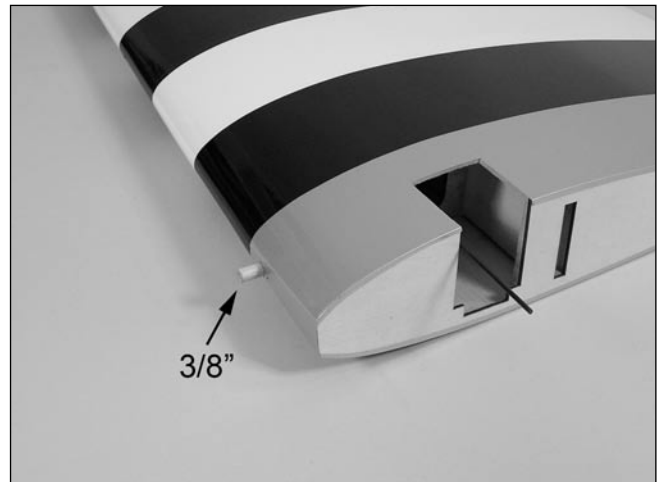

□ Step 5

Without using any glue, test fit the wing panels together using the wing joiner. The panels must fit together without any gaps top or bottom. If any gaps do exist, use a sanding bar to lightly sand the root ribs of both panels until the panels fit together perfectly.

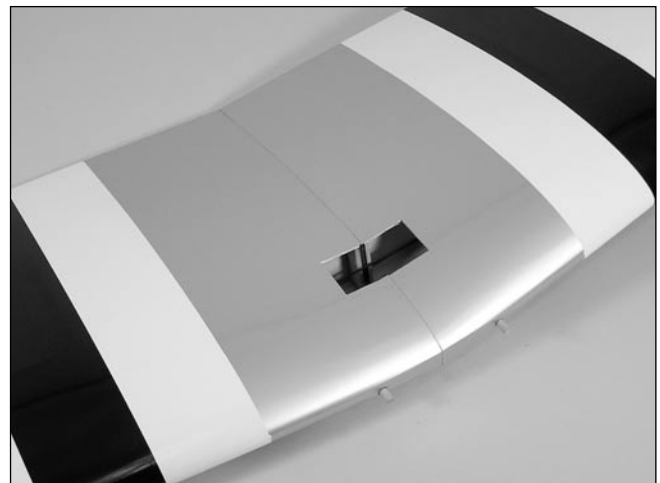

Section 1: Joining the Wing Halves

Note: Read through the remaining steps of this section before mixing any epoxy.

Hint: It is extremely important to use plenty of epoxy when joining the wing panels. It will also be helpful to use wax paper under the wing joint to avoid gluing the wing to your work surface.

□ Step 6

Mix approximately 1 ounce of 30-minute epoxy. Using an epoxy brush, apply a generous amount of epoxy to the wing joiner cavity of one of the wing panels.

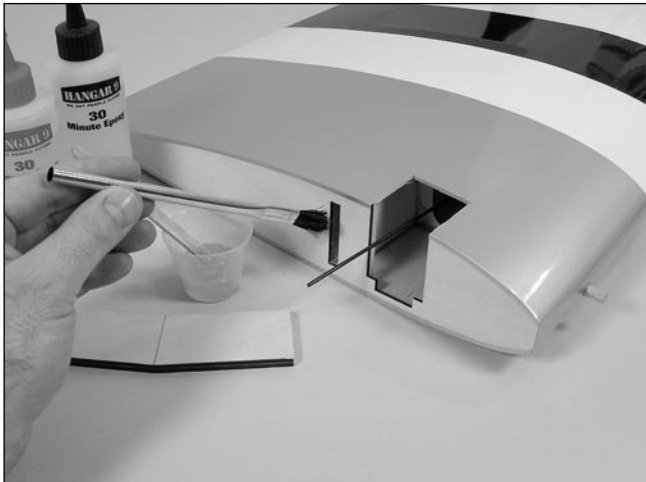

□ Step 7

Completely coat half of the wing joiner with epoxy. Be sure to apply epoxy to the top and bottom of the joiner also. Insert the epoxy-coated side of the joiner into the wing joiner cavity up to the mark on the joiner. If you have used enough epoxy, it will ooze out of the cavity as the joiner is installed. Remove any excess epoxy using a paper towel and rubbing alcohol.

□ Step 8

Apply epoxy to the exposed portion of the wing joiner and to both root wing ribs of both panels.

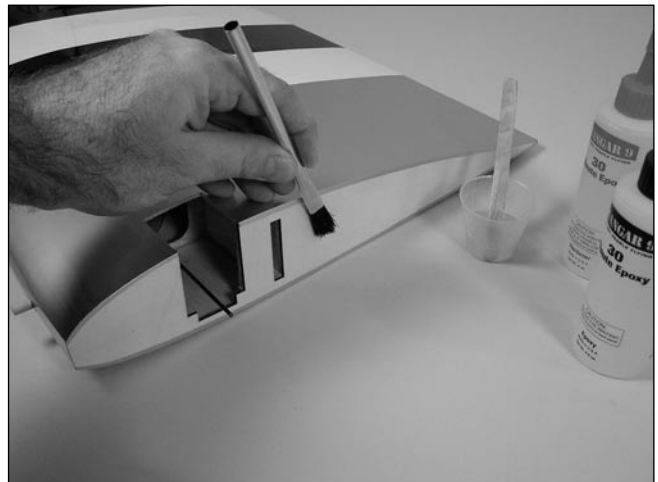

Section 1: Joining the Wing Halves

□ Step 9

Carefully slide the wing panels together. Apply enough pressure to firmly seat the two wing panels together, causing any excess epoxy to ooze out from between the panels. Use rubbing alcohol and a paper towel to remove the excess epoxy. Check to make sure there are no visible gaps between the panels. Use masking tape to securely hold the wing panels together. Allow the epoxy to fully cure before continuing to the next section.

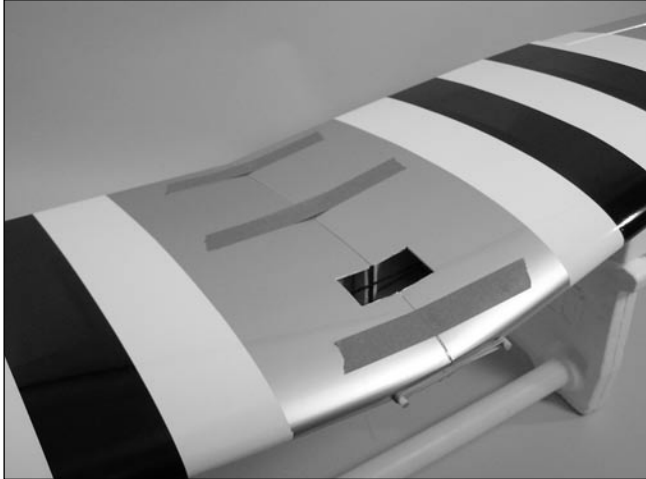

□ Step 10

Center the wing bolt plate on the bottom of the wing and trace the placement of the plate onto the wing using a felt-tipped pen.



□ Step 11

Remove the covering 1/16" inside the line drawn using a sharp hobby knife. Remove the lines from the wing using rubbing alcohol and a paper towel. Use medium CA to glue the plate in position.



□ Step 12

Use a 1/4" drill bit and drill through the place for the wing bolts.

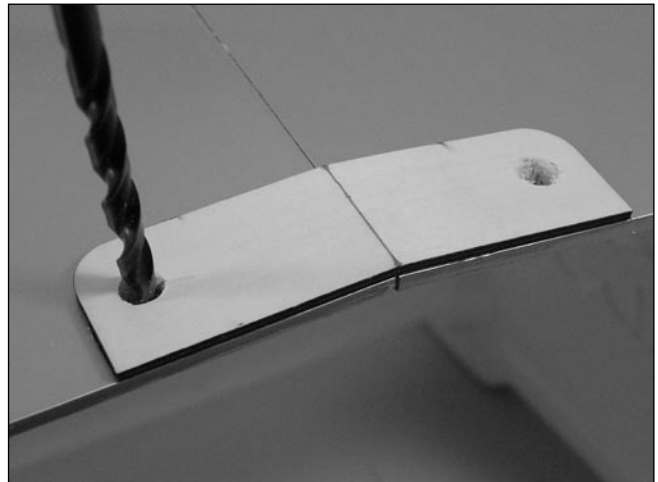

Section 2: Attaching the Wing

Required Parts

- Assembled wing
- Fuselage
- 1/4-20 blind nut (2)
- 1/4" washer (2)
- 1/4-20 x 1 1/2" socket head bolt (2)
- Fiberglass wing fairing

Required Tools and Adhesives

- 30-minute epoxy
- Pliers
- Hex wrench: 3/16"

□ Step 1

Locate the two 1/4-20 blind nuts. Mix a small amount of 30-minute epoxy and apply it to the barbs of the blind nut. Use pliers or a C-clamp to install the blind nut from the inside of the fuselage.



Note: Make sure no epoxy gets into the threads of the blind nut.

□ Step 2

Use the two 1/4 x 1 1/2" socket head bolts and 1/4" washers to attach the wing to the fuselage.

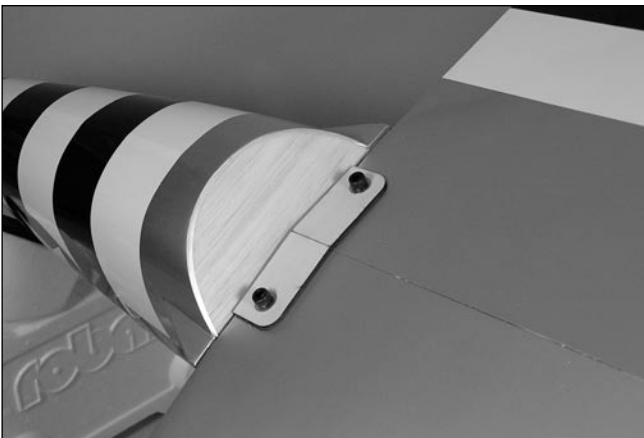

□ Step 3

Measure the distance between a point centered at the rear of the fuselage and each wing tip. The measurement will be equal if the wing is aligned correctly. If the measurement is not the same, slightly oval the hole for the wing bolts until an equal measurement is achieved.

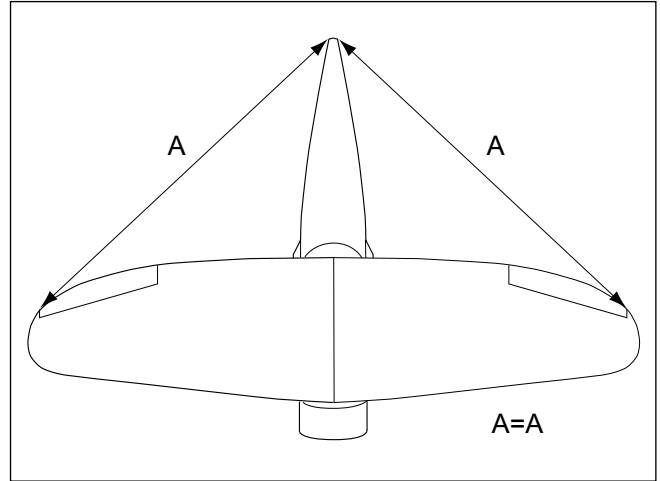

□ Step 4

Position the fiberglass wing fairing onto the wing. Trace around the fairing using a felt-tipped pen.



Section 2: Attaching the Wing

Step 5

Remove a strip of covering that is 1/8" wide inside the lines drawn in the previous step. **Use care not to cut into the underlying wood, weakening the wing structure.**



Step 6

Use 30-minute epoxy to glue the fairing to the wing. Use a covering iron to apply the trim covering along the joint between the wing fairing and the wing.



Section 3: Installing the Horizontal Stabilizer

Required Parts

- Assembled wing
- Fuselage
- Stabilizer
- Elevator joiner wire
- 1/4-20 x 2" wing bolt (2)

Required Tools and Adhesives

- Hobby knife
- Felt-tipped pen
- Ruler

Step 1

Slide the stab into the fuselage, making sure the stabilizer is as far forward as possible. Center the stab in the opening by measuring the distance from the fuselage to each tip. The stab is aligned when both measurements are identical.



Step 2

Check the distance from each stab tip to a center point at the firewall. These measurements must be equal for the stab to be aligned.

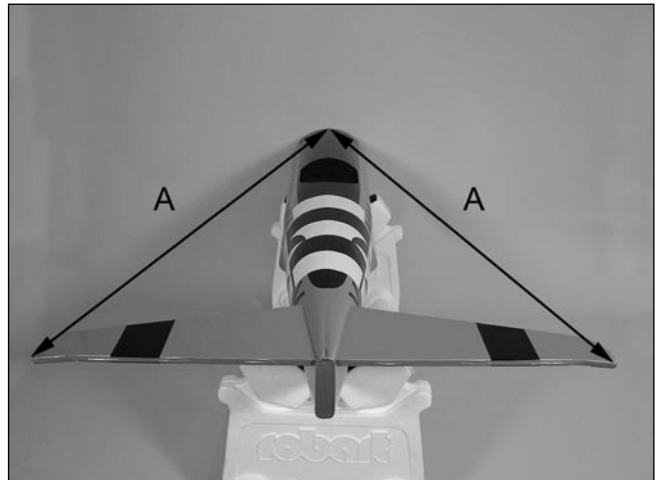

Section 3: Installing the Horizontal Stabilizer

□ Step 3

Check to make sure the wing and stabilizer are parallel. If they are not, lightly sand the opening in the fuselage for the stab until the stab is parallel to the wing.

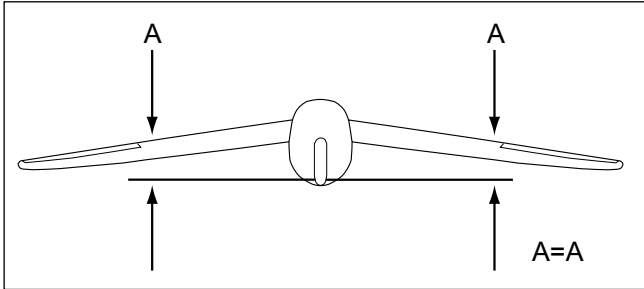

□ Step 4

After verifying the alignment of the stabilizer, use a felt-tipped pen to trace the outline of the fuselage on the stab.

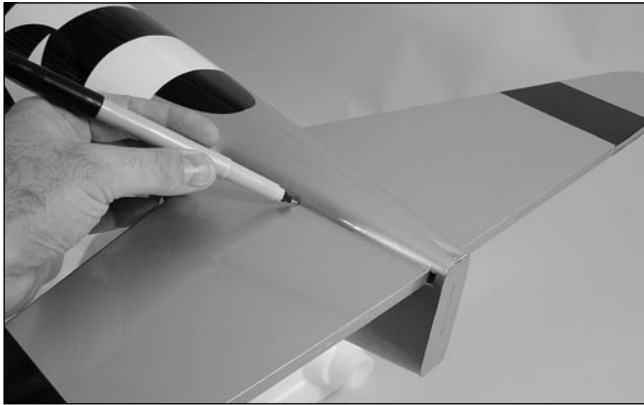

□ Step 5

Remove the stab and use a hobby knife with a new blade to remove the covering 1/16" inside the lines just drawn. Use rubbing alcohol and a paper towel to remove the lines once they are no longer needed.

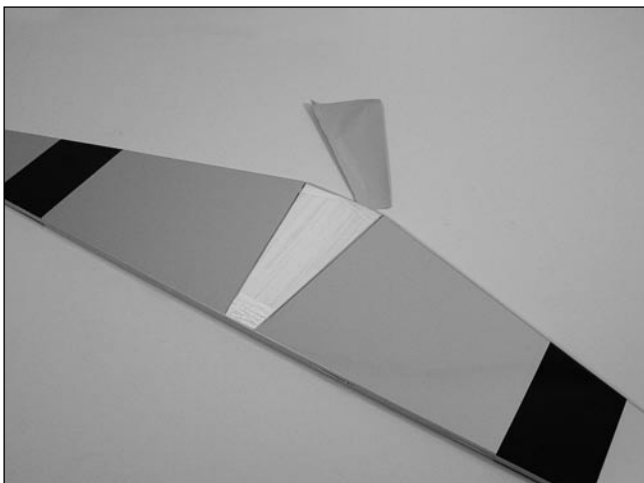

Note: Use care not to cut into the underlying wood and weaken the structure. Doing so could cause the stab to fail in flight, resulting in the loss of your airplane.

□ Step 6

Slide the elevator joiner wire into the slot for the stabilizer. Slide the stabilizer partially back into the slot.

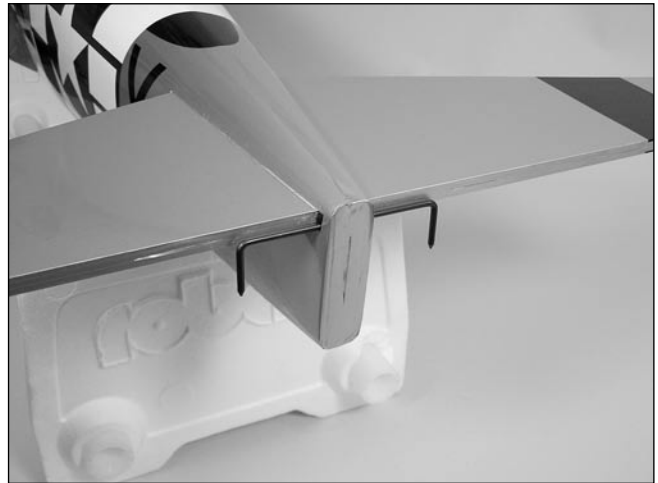

□ Step 7

Mix 1/2 ounce of 30-minute epoxy. Apply epoxy to the top and bottom of the exposed wood of the stabilizer. Slide the stabilizer the rest of the way into the slot in the fuselage. Double-check the alignment to verify it's correct. Remove any excess epoxy using a paper towel and rubbing alcohol. Allow the epoxy to fully cure before continuing.



Section 4: Installing the Vertical Stabilizer

Required Parts

- Fuselage assembly
- Tail wheel wire
- Tail wheel wire support bracket
- Fin
- Steering control arm

Required Tools and Adhesives

- 30-minute epoxy
- Square
- Pliers
- 6-minute epoxy
- Hobby knife
- Ruler

□ Step 1

Remove the covering from the fuselage for the vertical fin. Test fit the fin to the fuselage. Slide the fin as far back in the slot as possible. Trace the outline of the fuselage onto the fin using a felt-tipped pen. Trace the outline of the dorsal fin onto the top of the fuselage as well.



□ Step 2

Remove the fin and use a hobby knife with a new blade to remove the covering 1/16" below the lines just drawn. Use rubbing alcohol and a paper towel to remove the lines once they are no longer needed. Remove the covering from the bottom of the dorsal fin and the top of the fuselage.

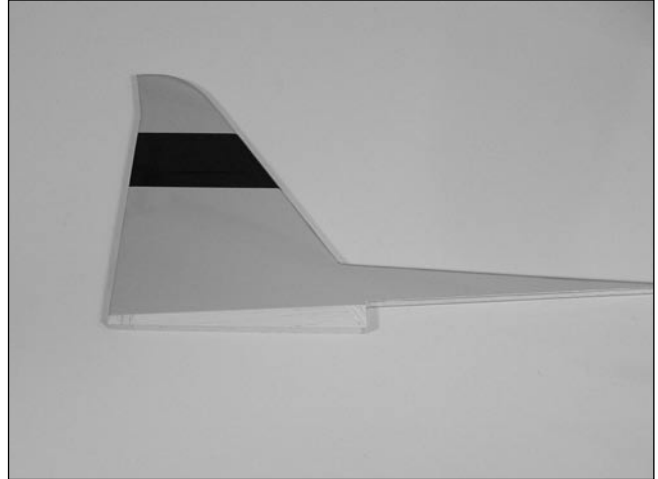

Note: Use care not to cut into the underlying wood and weaken the structure. Doing so could cause the fin to fail in flight, resulting in the loss of your airplane.

Section 4: Installing the Vertical Stabilizer

□ Step 3

Slide the fin back into the fuselage. Check the alignment of the fin to the stabilizer using a square. The fin must be 90 degrees to the stabilizer when properly aligned.

If not, carefully sand the bottom of the fin to provide the clearance to align the fin.

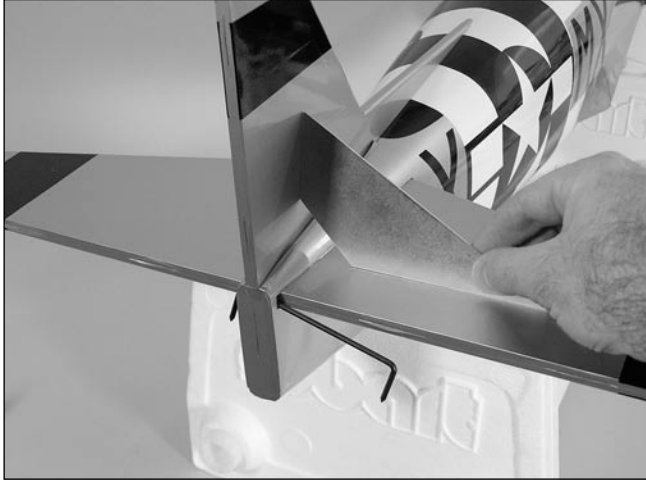

□ Step 4

Mix 1/2 ounce of 30-minute epoxy. Apply the epoxy to both the exposed wood on the fin and the slot in the fuselage. Use care not to get epoxy on the elevator joiner wire. Insert the fin and use tape to hold the fin in position until the epoxy fully cures.

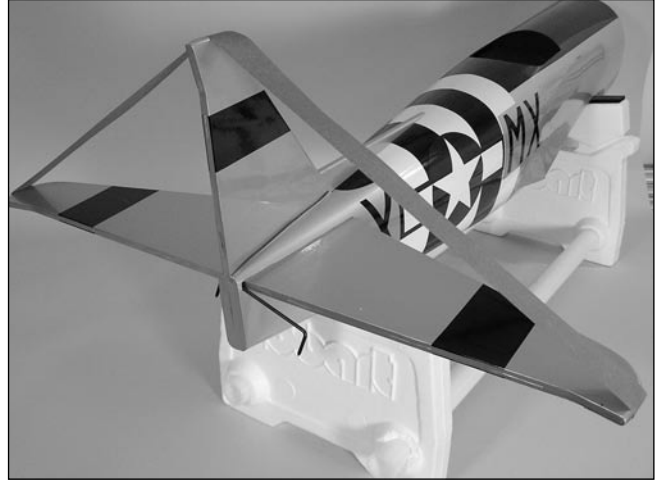

Note: Check the alignment of the fin periodically to make sure it isn't moving while the epoxy cures.

Section 5: Installing the Ailerons

Required Parts

- Wing
- CA hinges (6)
- Aileron (left and right)

Required Tools and Adhesives

- Thin CA
- T-pins

□ □ Step 1

Remove the aileron from the wing. Place a T-pin in the center of each hinge.

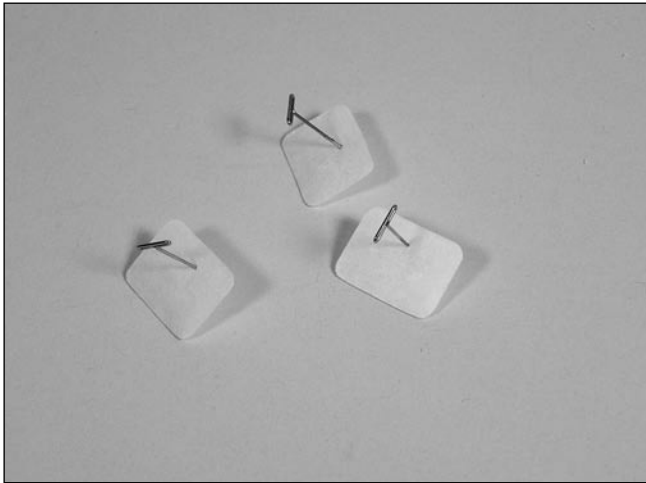

□ □ Step 2

Place the hinges in the precut slots in the aileron. The T-pin will rest against the leading edge of the aileron when installed correctly.

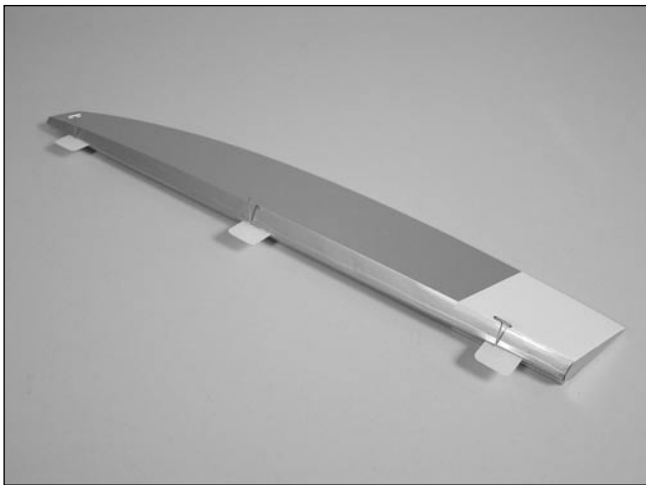

□ □ Step 3

Slide the aileron and wing together. The gap between the leading edge of the aileron and wing should be a maximum of approximately 1/64". Check to make sure the gap, at both ends of the aileron, is equal and the aileron can move without rubbing on the wing.



Note: Do not use CA accelerator during the hinging process. The CA must be allowed to soak into the hinge to provide the best bond. Using accelerator will not provide enough time for this process.

□ □ Step 4

Remove the T-pins and move the aileron to provide the best access to the hinge. Apply thin CA to each hinge. Make sure the hinge is fully saturated with CA. Use a paper towel and CA remover/debonder to clean up any excess CA from the wing and/or aileron. Make sure to apply CA to both sides of the hinges.

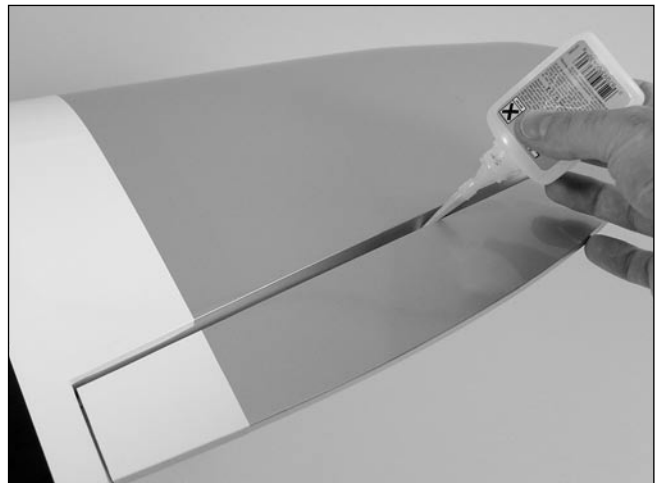

Section 5: Installing the Ailerons

Step 5

Firmly grasp the wing and aileron and gently pull on the aileron to ensure the hinges are secure and cannot be pulled apart. Use caution when gripping the wing and aileron to avoid crushing the structure.



Step 6

Work the aileron up and down several times to work in the hinges and check for proper movement.

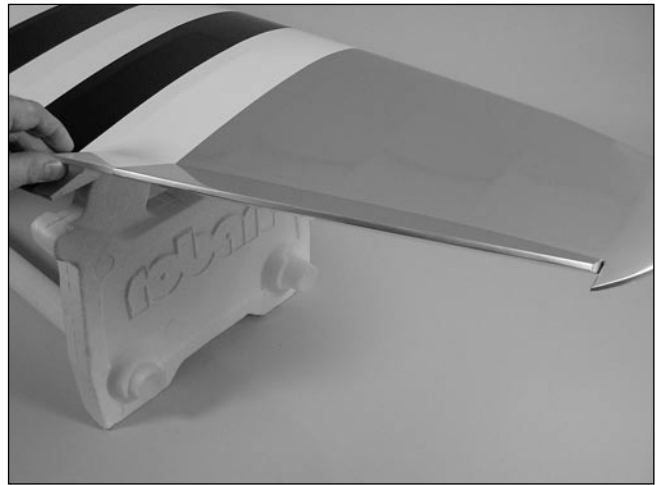

Step 7

Repeat Steps 1 through 6 for the remaining aileron.

Section 6: Installing the Elevators

Required Parts

- Fuselage assembly
- Elevator (left and right)
- Elevator joiner wire
- CA hinge (6)

Required Tools and Adhesives

- Thin CA
- 30-minute epoxy
- Drill
- T-pins
- Medium sandpaper
- Drill bit: 9/64"

□ □ Step 1

Locate three CA hinges. Place a T-pin in the center of the hinges. Place the hinges into the elevator half.

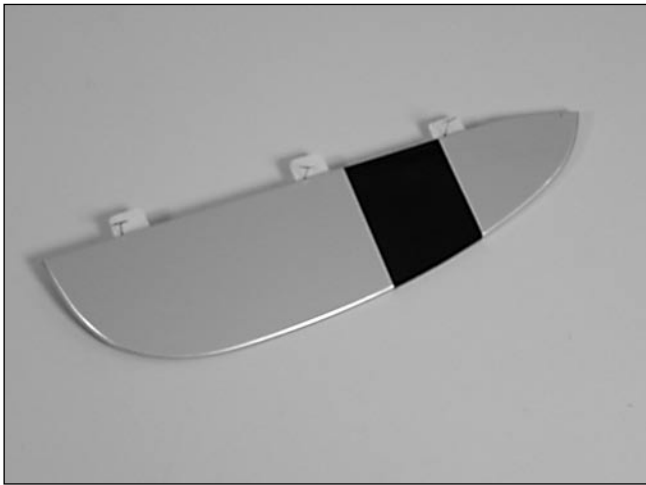

□ □ Step 2

Test fit the elevator and stab together. The elevator joiner wire will be inserted into the hole drilled in the elevator.

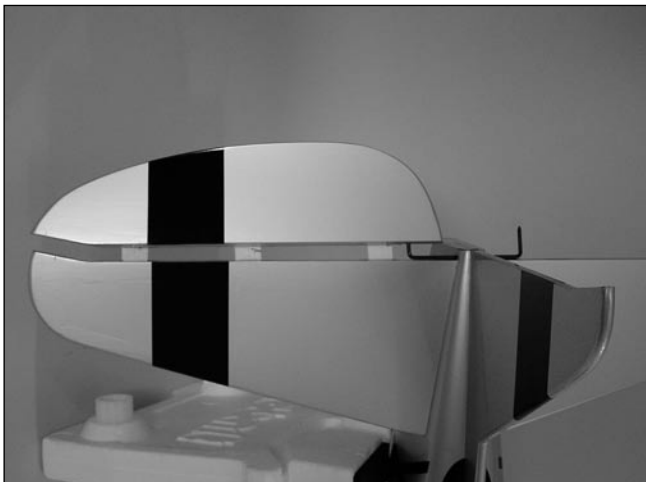

□ □ Step 3

Mix 1/2 ounce of 30-minute epoxy and apply it to the groove and hole in the elevator half. Insert the elevator joiner wire. Remove any excess epoxy using rubbing alcohol and a paper towel.

Note: You can combine the previous step with the following step if you like. This will hold the elevator in position while the epoxy cures.

□ □ Step 4

Check to make sure the elevator moves freely. Check to make sure the hinge gap between the elevator and stabilizer is roughly 1/64". Apply thin CA to both sides of the hinge. Make sure to saturate the hinge and don't use accelerator.



□ □ Step 5

Once the CA and epoxy have fully cured, gently pull on the elevator and stab to make sure the hinges are well glued. Flex the elevators a few times to break-in the hinges following the same procedure as the aileron installation.

□ Step 6

Repeat Steps 1 through 5 to install the remaining elevator half.

Section 7: Rudder Installation

Required Parts

- Fuselage assembly
- Tail wheel assembly
- #2 x 3/8" sheet metal screw (2)
- Rudder
- Tail wheel bracket

Required Tools and Adhesives

- 6-minute epoxy
- Drill bit: 1/8"
- T-pins
- Drill
- Thin CA

□ Step 1

Roughen the tail gear wire using medium grit sandpaper where it will enter the rudder. Use 6-minute epoxy to glue the wire into the rudder.



□ Step 2

Locate three CA hinges. Place a T-pin in the center of the hinges. Place the hinges into the rudder. Slide the hinges and rudder into position. Check that the gap between the rudder and fin is roughly 1/64". Apply thin CA to both sides of the hinges. Perform the pull test after the CA has fully cured.

□ Step 3

Secure the tail wheel bracket to the fuselage using two #2 x 3/8" sheet metal screws.



□ Step 4

Slide the wheel collar against the tail wheel bracket and tighten the setscrew.



Section 8: Retract Linkage Installation

Required Parts

- Quick connector (2)
- Quick connector washer (2)
- Quick connector retainer (2) • 3mm setscrew (2)
- Retract servo tray mount (2) • Retract servo tray
- 3 1/4" main wheel (2) • 5/32" wheel collar (2)
- 3mm setscrew (4)
- 8 7/8" unthreaded retract wire (2)

Required Tools and Adhesives

- 6-minute epoxy
- Thick CA
- Retract Servo (JRPS703)
- Hobby knife
- Drill
- Drill bit: 1/16", 5/64"
- Hex wrench (included in kit)

□ Step 1

Notes regarding the retracts:

The included mechanical retracts may require some adjustment after about 30 minutes of flight to keep them in the best working order. The following clarifies the operation of the retract, as well as how to make future adjustments to keep your retracts working as well as they did when new.

Installation

When installing the linkage, make sure the actuator rod is moving to the full up and down positions without binding the servo. Increase the throw by moving the linkage outward on the servo arm. Decrease the throw by moving the linkage inward on the servo arm.

If the servo is binding, it will add extra current draw to the receiver battery and will greatly reduce flight times. Change the location of the linkage at the servo arm inward slightly to eliminate binding.

After flying for around 30 flights, you may notice that the retracts will begin to have a little play. This is normal and can easily be adjusted out. There are two setscrews to adjust the up and down stops for these retracts.

Adjustments

Adjust the retract down stop by screwing the setscrew in slightly. It will only take a small amount, so start by turning it around 1/16 of a turn. If the setscrew is tightened too much, the retract can bind and stall the servo, placing unnecessary current loads on the receiver battery.

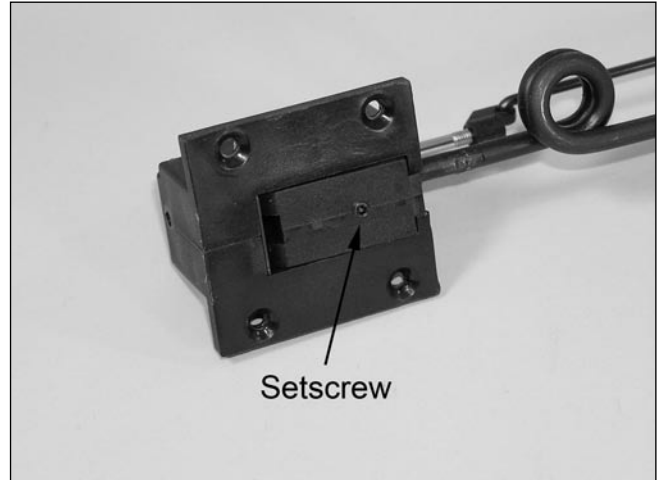

The adjustment procedure is common after about 30 flights, depending on your runway surface. Check the operation of your retracts often to keep them in the best working order. Keep this section handy for future reference for your P-47 Thunderbolt retracts.

□ Step 2

Use 6-minute epoxy to glue the two retract servo tray mounts into the wing as shown. They will rest flush with the wing sheeting on the inside of the wing.



Section 8: Retract Linkage Installation

□ Step 3

Locate the retract servo tray. Use 6-minute epoxy to glue the servo tray into position.



□ Step 4

Install a low profile retract servo in the servo tray using the hardware provided with the servo. Prevent splitting the servo tray by drilling 1/16" holes for the servo mounting screws.

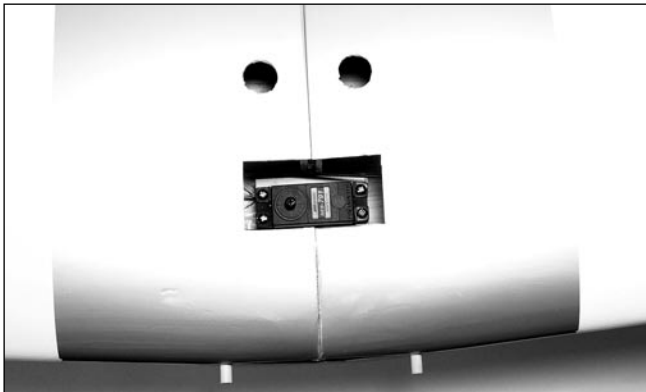

□ Step 5

Select a servo arm from those included with your servo that has a distance of 7/8" to 1" between equally spaced holes as shown to start with.

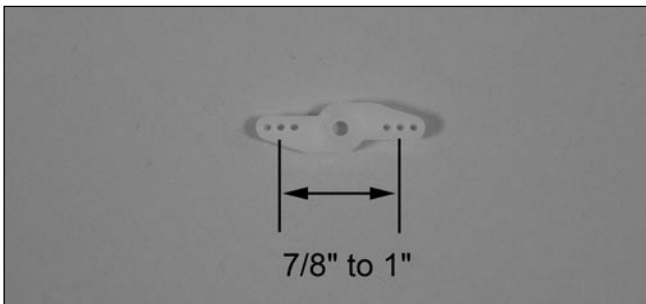

□ Step 6

Use a 5/64" drill bit to drill the appropriate holes in the arm. Attach two quick connectors to the servo arm using quick connector washers and retainers.

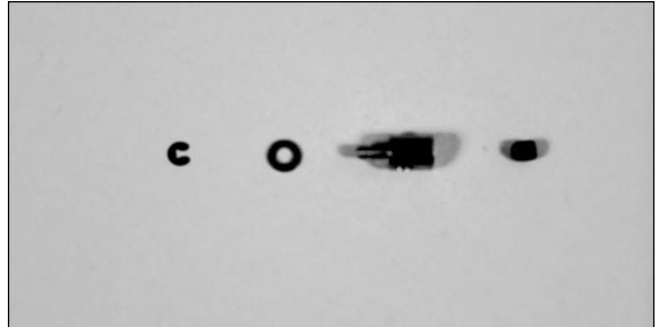

□ Step 7

Connect the retract servo to your radio system and electronically move the servo to the retracted position. Slide the retract control wires through the quick connectors as shown and secure the servo arm to the retract servo.

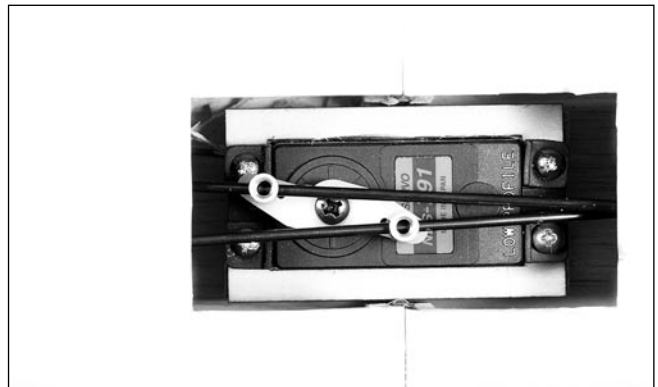

Section 8: Retract Linkage Installation

□ Step 8

With the retract servo in the retracted position, push the retract linkage to manually retract the landing gear. Install 3mm setscrews into the quick connectors and tighten them to secure the retract linkage. Check the actuation of the retracts, making sure they lock in both the up and down positions. Make any necessary adjustments to the linkages as necessary for proper operation of the retracts.

Hint: Adjustments and fine tuning can also be made to the retract linkages from inside the wheel wells.

Remember: It may take some time to get the retracts adjusted so the servo does not stall when the landing gear is up and extended.

□ □ Step 9

Draw a centerline onto the back of one of the gear doors.

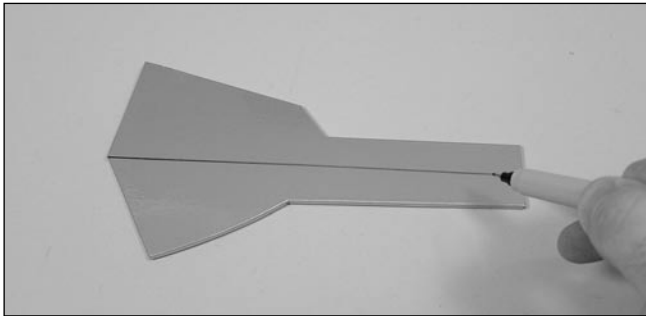

□ □ Step 10

Locate two of the gear door brackets. Position the brackets $2\frac{1}{4}$ " and 5" from the top of the door. Mark the locations for the screws using a felt-tipped pen. Drill the locations using a $\frac{1}{8}$ " drill bit.

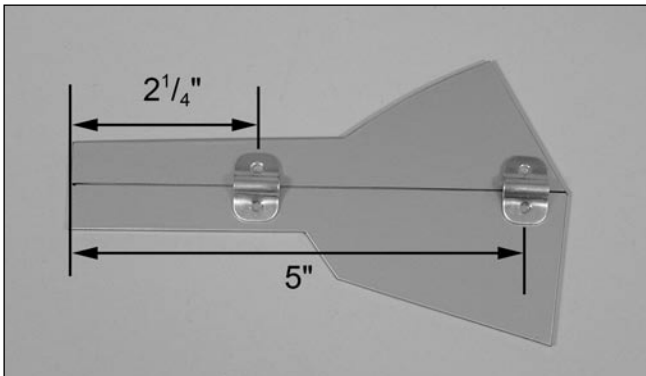

□ □ Step 11

Attach the gear doors using four 3mm x 10mm screws, four 3mm lock nuts, eight 3mm washers and two gear door brackets.



□ □ Step 12

Install a wheel and two wheel collars on the main landing gear. The order of items is $\frac{5}{32}$ " wheel collar, wheel, and then another wheel collar. Secure the collars using the 3mm setscrews.



□ Step 13

Repeat Steps 9 through 12 to complete the retract installation.

Section 9: Four-Stroke Engine Installation

Required Parts

- Fuselage
- Engine mount (2)
- 8-32 nylon lock nut (4)
- 8-32 blind nut (4)
- #8 washer (8)
- Engine
- 8-32 x 1 1/4" socket head screw (4)
- 8-32 x 1" socket head screw (4)

Required Tools and Adhesives

- Hex Wrench: 9/64"
- Ruler
- Adjustable wrench
- 11/32" socket wrench
- Felt-tipped pen
- Medium CA
- 2-56 x 18" pushrod
- Plastic pushrod sleeve (12")

□ Step 1

Locate the engine mount and the associated hardware. Temporarily install the engine to the fuselage using four 8-32 x 1" socket head screws, four #8 washers and four blind nuts. Leave the bolts loose enough not to draw the blind nuts into the wood inside the fuselage.



Hint: You can also install the blind nuts backwards to prevent them from pulling into the wood on the backside of the firewall. Just remember to move them to their correct positioning before moving to the next section.

□ Step 2

Position the engine on the mount and temporarily attach the engine using four 8-32 x 1 1/4" socket head screws, four #8 washers and four nylon lock nuts. Position the engine so the front of the drive washer is 5 1/8" from the firewall. Tighten the bolts holding the engine once the engine is positioned.

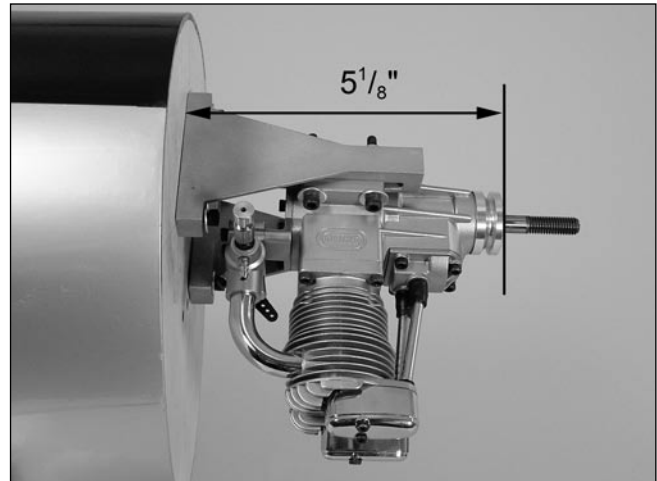

Section 9: Four-Stroke Engine Installation

□ Step 3

Center the engine mount in relationship to the oval holes in the firewall. Tighten the bolts holding the mount to the firewall. (Remember to make sure the barbs on the blind nuts go into the backside of the firewall.) Test fit the throttle pushrod tube into the fuselage. Once satisfied with the fit, roughen the tube using medium sandpaper. Slide the tube back into position and use medium CA to glue it to the firewall.

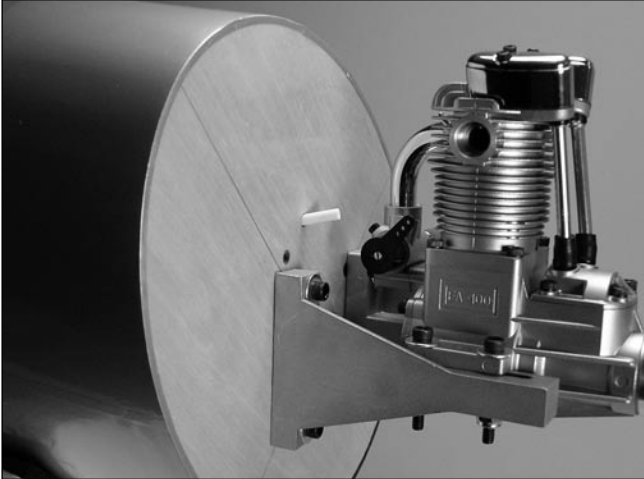

□ Step 4

Position the throttle servo tray so the opening for the servo is on the same side of the fuselage as the throttle pushrod tube. Use Medium CA to glue the tray into position.

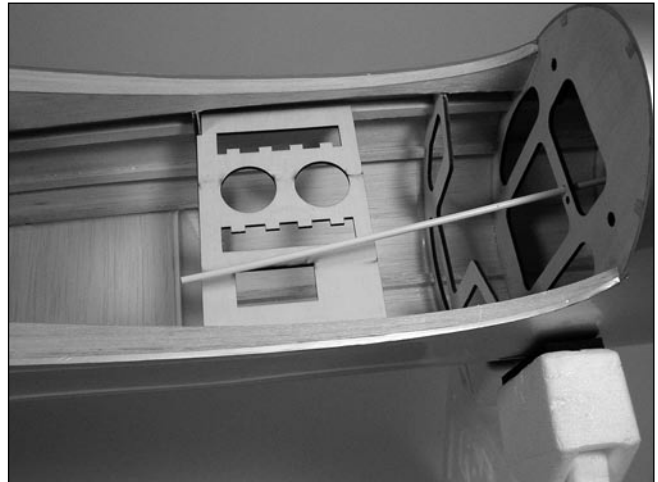

□ Step 5

Attach the "Z" bend on the throttle pushrod wire onto the carburetor arm. Slide the pushrod wire into the tube.



Section 10: Two-Stroke Engine Installation

Required Parts

- Fuselage
- Engine mount (2)
- 8-32 nylon lock nut (4)
- 8-32 blind nut (4)
- #8 washer (8)
- Engine
- 8-32 x 1 1/4" socket head screw (4)
- 8-32 x 1" socket head screw (4)

Required Tools and Adhesives

- Hex Wrench: 9/64"
- Ruler
- Adjustable wrench
- 11/32" socket wrench
- Felt-tipped pen
- Medium CA
- 2-56 x 18" pushrod
- Plastic pushrod sleeve (12")

□ Step 1

Locate the engine mount and the associated hardware. Temporarily install the engine to the fuselage using four 8-32 x 1" socket head screws, four #8 washers and four blind nuts. Leave the bolts loose enough not to draw the blind nuts into the wood inside the fuselage.

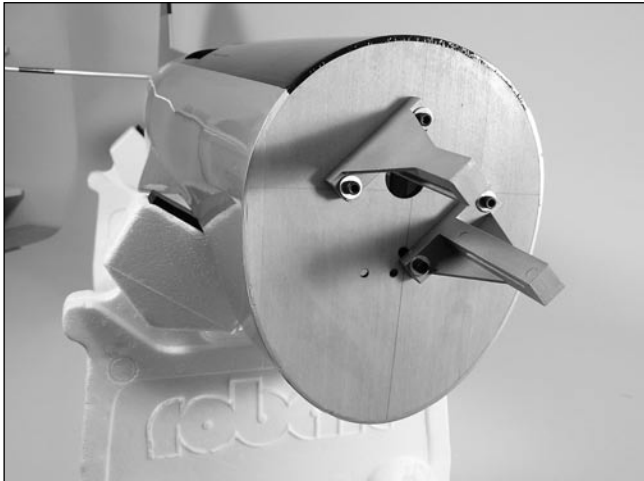

Hint: You can also install the blind nuts backwards to prevent them from pulling into the wood on the backside of the firewall. Just remember to move them to their correct positioning before moving to the next section.

□ Step 2

Position the engine on the mount and temporarily attach the engine using four 8-32 x 1 1/4" socket head screws, four #8 washers and four nylon lock nuts. Position the engine so the front of the drive washer is 5 1/8" from the firewall. Tighten the bolts holding the engine once the engine is positioned.

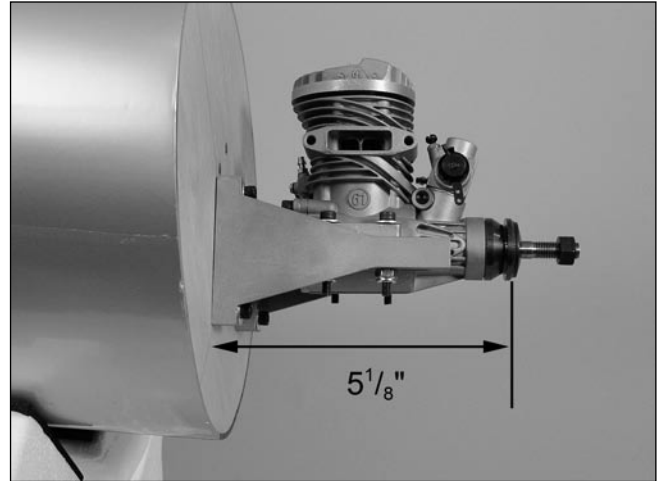

Section 10: Two-Stroke Engine Installation

□ Step 3

Center the engine mount in relationship to the oval holes in the firewall. Tighten the bolts holding the mount to the firewall. (Remember to make sure the barbs on the blind nuts go into the backside of the firewall.) Test fit the throttle pushrod tube into the fuselage. Once satisfied with the fit, roughen the tube using medium sandpaper. Slide the tube back into position and use medium CA to glue it to the firewall.

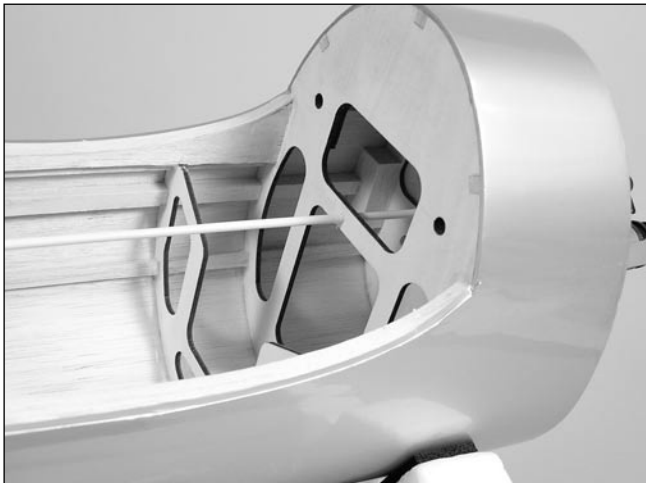
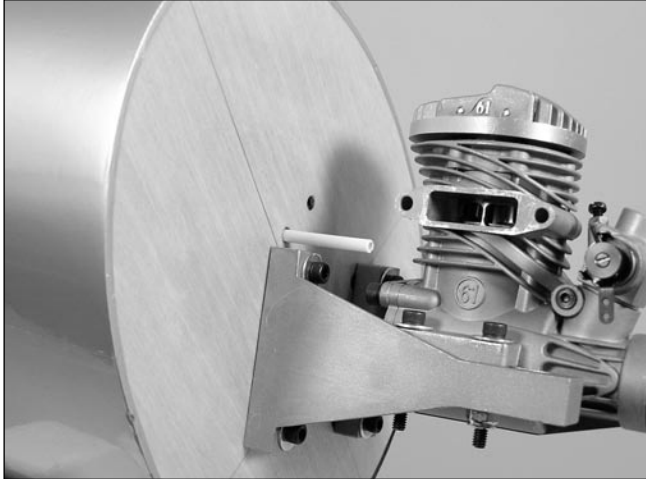

□ Step 4

Position the throttle servo tray so the opening for the servo is on the same side of the fuselage as the throttle pushrod tube. Use Medium CA to glue the tray into position.

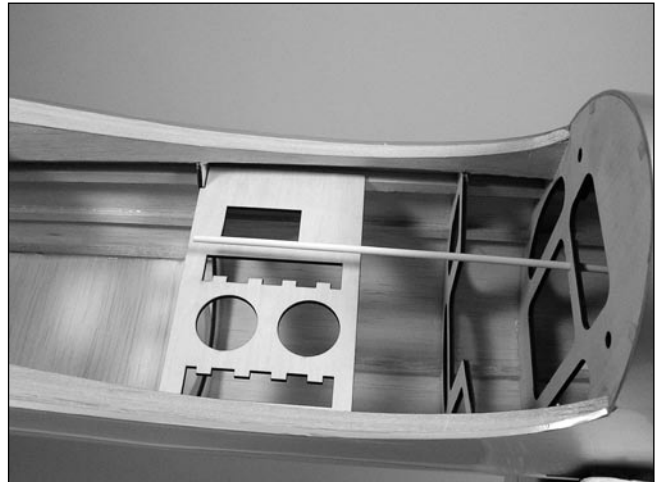

□ Step 5

Attach the "Z" bend on the throttle pushrod wire onto the carburetor arm. Slide the pushrod wire into the tube.

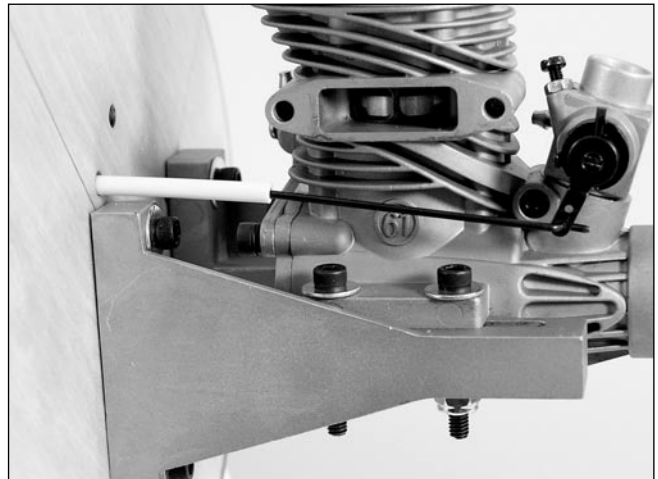

Section 11: Fuel Tank Installation

Required Parts

- Fuselage assembly
- Fuel tank assembly

Required Tools and Adhesives

- Hobby knife
- Fuel tubing
- Foam: 1/4"
- Masking tape
- Phillips screwdriver (small)

□ □ Step 1

Mark the vent tube on the fuel tank. This will be helpful after the tank has been mounted in the fuselage.

Note: When installing the fuel tank, make sure to have a piece of foam at any point that contacts any structure inside the fuselage. Without the foam, vibrations will be transmitted to the fuel tank, which could cause the fuel to foam. In turn, you will not get the optimum performance from your engine.

□ □ Step 2

Connect two 8" pieces of fuel tubing for pickup and vent tubes.



□ □ Step 3

Install the fuel tank into the fuselage. Make any necessary supports to keep the tank from moving during flight. Make sure the vent tube faces towards the top of the fuselage.

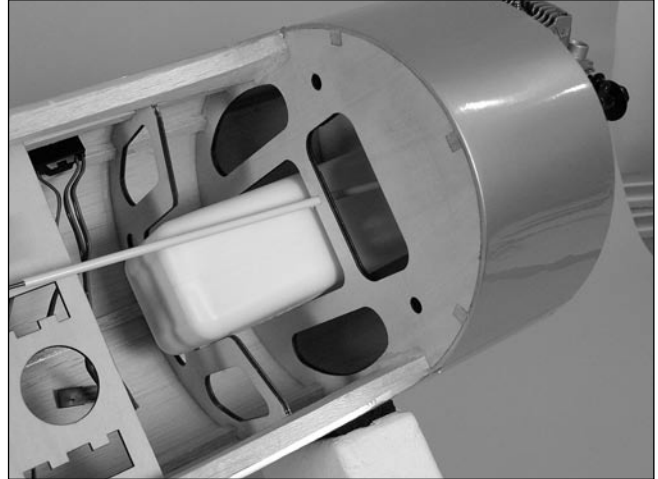

Note: Make sure that any support braces installed will not interfere with the installation of the wing or linkages.

□ □ Step 4

Make the proper connections to the engine, using the engine manufacturer's instructions. If you are using a 4-stroke, make sure to route the crankcase vent to the outside of the cowling.



Section 12: Radio Installation

Required Parts

- Fuselage assembly
- Wing assembly
- Servo w/hardware (5)
- #2 x 3/8" screws (8)
- 3/8" x 5/8" x 5/8" servo mounting block (4)

Required Tools and Adhesives

- Drill
- Drill bit: 1/16"
- 6-minute epoxy
- Thin CA
- Felt-tipped pen
- Hobby knife
- Ruler
- Phillips screwdriver (small)
- 12" Servo Extension (JRPA098) (2)
- 18" Servo Extension (JRPA099) (2)

□ Step 1

Install the recommended servo hardware (grommets and eyelets) supplied with your radio system onto five servos (elevator, rudder, throttle and 2 ailerons). Mark the locations for the servo screws using a felt-tipped pen. Remove the servo and drill the holes for the servo mounting screws using a 1/16" drill bit. Secure the throttle servo using the screws provided with the servo.

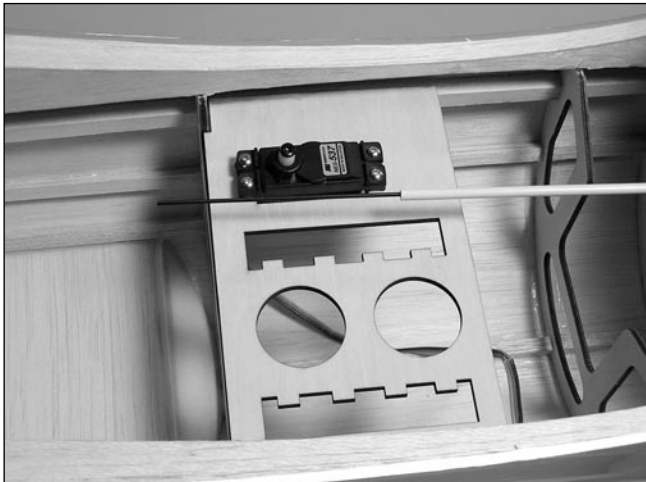

Hint: Place a drop of thin CA onto each screw hole to harden the wood around the hole. Allow the CA to fully cure before installing the servos.

□ Step 2

Remove the covering from the opening on the side of the fuselage for the rudder servo. Connect an 18" Servo Extension (JRPA099) to the servo lead. Secure the connectors by tying them in a knot using dental floss or by using a commercially available connector clamp to prevent the servo leads from becoming disconnected.

Note: It is always a good idea to secure the servo connector and servo extension together to prevent the wires from becoming unplugged.

□ Step 3

Temporarily install the rudder servo. Mark the locations for the servo screws using a felt-tipped pen. Remove the servo and drill the holes for the servo mounting screws using a 1/16" drill bit. Secure the rudder servo using the screws provided with the servo.



□ Step 4

Repeat Steps 2 and 3 for the elevator servo.



Section 12: Radio Installation

Step 5

Mount the radio switch to the side of the fuselage.



Step 6

Wrap the receiver and receiver battery in protective foam to prevent damage that may be caused by engine vibration. Connect any necessary extensions and Y-harnesses necessary to connect the retract and aileron servos. Connect the elevator, rudder and throttle servo leads to the receiver.

Step 7

Use rubber bands or a hook and loop strap to attach the receiver and battery to the radio tray. It may be necessary to relocate the battery forward or aft to balance the model as described in the section "Control Throws and Center of Gravity."



Step 8

Route the antenna through the bottom of the fuselage and secure it to a location at the tail with rubber bands.

Step 9

Remove the aileron hatch from the wing. Remove the covering from the slot for the aileron horn.

Note: The aileron servo is mounted directly to the hatch.

Step 10

Install the recommended servo hardware (grommets and eyelets) supplied with the servo. Temporarily install a long half servo arm (JRPA212) onto the servo and position the servo onto the hatch so the servo arm is centered in the notch. Once satisfied, mark the location for the servo mounting blocks.

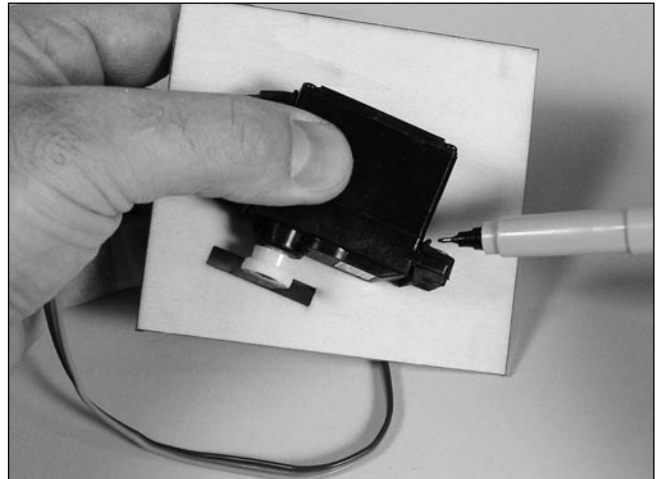

Section 12: Radio Installation

□ □ Step 11

Locate the 3/8" x 3/4" x 3/4" servo mounting blocks. Use 6-minute epoxy to glue the blocks to the hatch. Let the epoxy fully cure before proceeding to the next step.

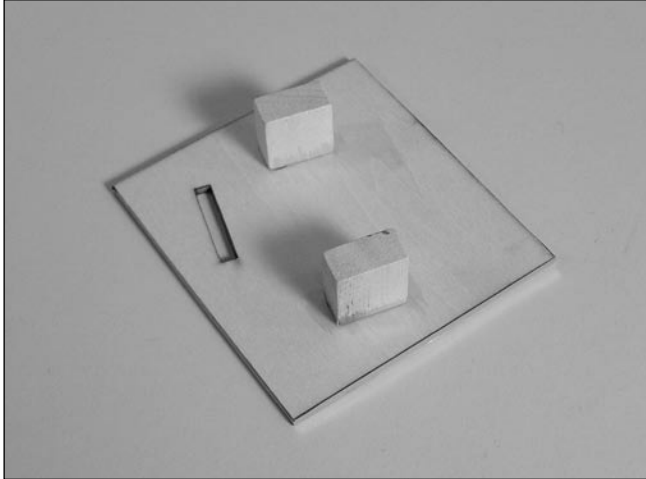

□ □ Step 12

Place the aileron servo between the mounting blocks and use a felt-tipped pen to mark the location of the four servo mounting screws. Note that the servo must not touch the hatch in order to isolate engine vibration.

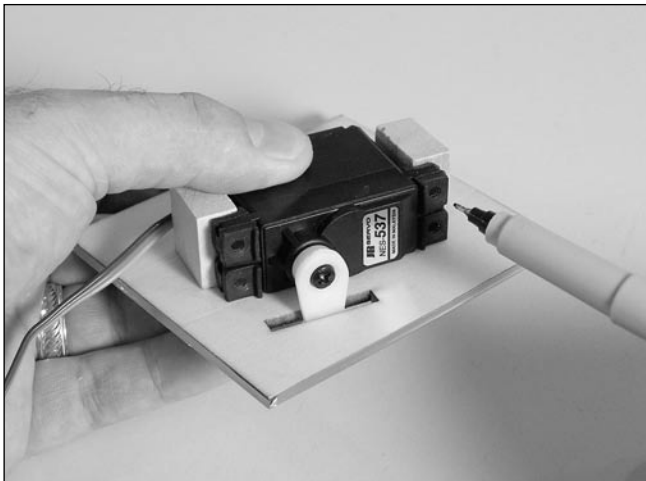

Note: Before mounting the servo, it is suggested to electronically center the servo using the transmitter, then install the servo arm to avoid having to remove the servo and center the arm later. It may be necessary to slightly trim one of the servo mounting blocks to clear the servo wire.

□ □ Step 13

Remove the servo and use a 1/16" drill bit to predrill the holes for the servo mounting screws marked in the previous step. Use the screws supplied with the servo to mount it to the servo mounting blocks.

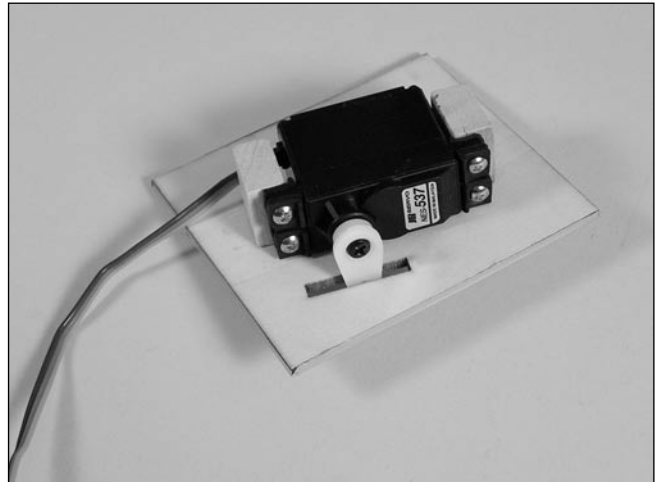

□ □ Step 14

Connect a 12" Servo Lead extension (JRPA098) to the servo lead. Secure the connectors by tying them in a knot using dental floss or by using a commercially available connector clamp to prevent the servo leads from becoming disconnected.

Note: It is always a good idea to secure the servo connector and servo extension together to prevent the wires from becoming unplugged.

Section 12: Radio Installation

□ □ Step 15

Tie the preinstalled string onto the servo extension. Gently pull the extension through the wing using the string. Untie the string when the servo lead has been pulled through. Use tape to secure the servo lead to the wing to prevent it from falling back into the wing panel.

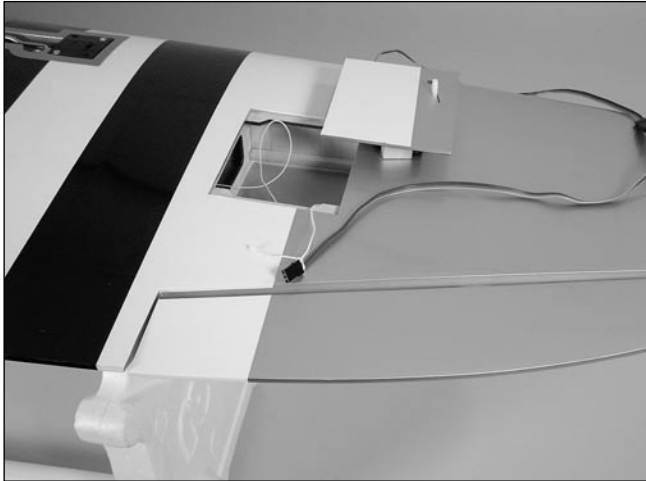

□ □ Step 16

Place the hatch cover in position in the aileron opening. Measure in 1/8" on all four sides of the hatch. Drill four 1/16" holes at the intersections of the lines as shown.

Note: Drill through the servo hatch and the underlying hatch mounts. Use caution not to accidentally drill through the top of the wing.

□ □ Step 17

Remove the servo hatch cover and re-drill the holes using a 5/64" drill bit. Use 2–3 drops of thin CA to harden the underlying wood. This will prevent the screws from crushing the wood when they are tightened. Secure the hatch using four #2 x 3/8" screws.



□ Step 18

Repeat Steps 9 through 17 for the remaining aileron servo.

Section 13: Linkage Installation

Required Parts

- Fuselage assembly
- 6" pushrod wire (4)
- Nylon clevis (4)
- Nylon control horn (3)
- Quick connector
- Quick connector backplate
- Wing assembly
- M3x6 machine screw
- Nylon wire keeper (4)
- 2-56 x 3/4" screw (6)
- 2-56 x 1 1/4" screw (6)

Required Tools and Adhesives

- Drill
- Drill bit: 1/16", 5/64", 3/32"
- Phillips screwdriver (small)

□ □ Step 1

Thread a clevis onto a 6" wire a minimum of 10 turns.

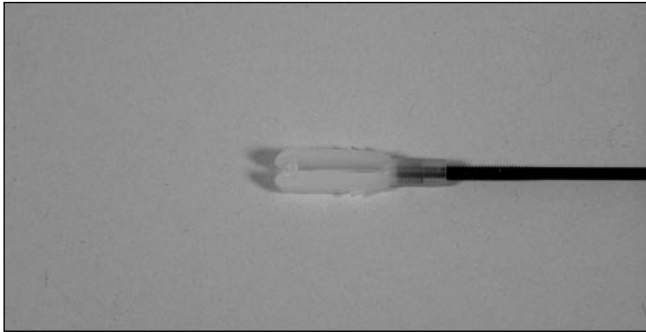

□ □ Step 2

Remove the back plate from a control horn using side cutters or a sharp hobby knife. Position the control horn on the elevator so the horn aligns with the hinge line of the elevator. Mark the position for the mounting holes using a felt-tipped pen.

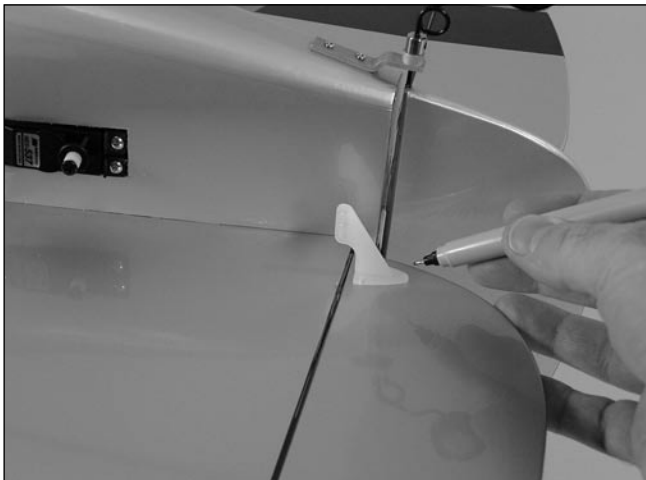

□ □ Step 3

Drill three 3/32" holes through the elevator at the locations marked in the previous step.



□ □ Step 4

Place 2–3 drops of thin CA into the hole to harden the wood. Repeat this for each of the three holes.



□ □ Step 5

Attach the control horn using three 2-56 x 1/2" screws and the control backplate.



Section 13: Linkage Installation

□ □ Step 6

Center the elevator servo electronically using the radio system. Install a servo arm onto the elevator servo. Attach the pushrod with clevis to the control horn. Physically place the elevator control surface in neutral. Mark the pushrod where it crosses the holes in the servo arm.



□ □ Step 7

Bend the wire 90 degrees at the mark made in the previous step. Cut the wire 3/8" above the bend. Slide the wire through the outer hole in the elevator servo arm. Secure the wire using a nylon wire keeper. It may be necessary to drill out the hole in the servo arm using a 5/64" drill bit.



Note: Use a 1/4" piece of heat shrink tubing on the clevis to keep it from opening during flight.

□ Step 8

Repeat Steps 1 through 7 for the rudder linkage.



□ □ Step 9

Remove the back plate from a control horn using side cutters or a sharp hobby knife. Position the control horn on the aileron so the horn aligns with the aileron servo horn and the aileron hinge line. Mark the position for the mounting holes using a felt-tipped pen.

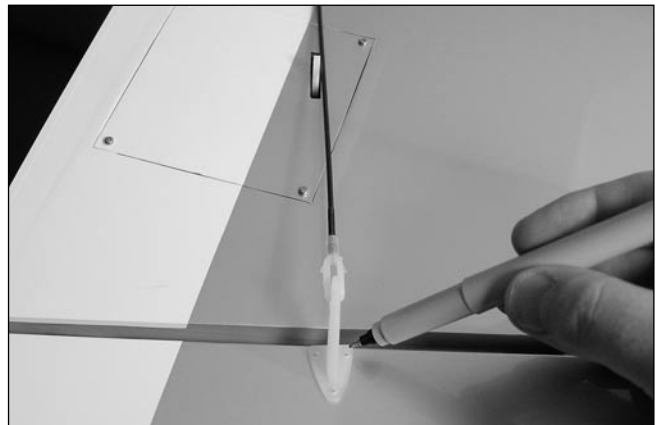

□ □ Step 10

Drill three 3/32" holes at the locations marked in the previous step. Apply thin CA to each of the three holes to harden the balsa. Attach the control horn using three 2-56 x 1 1/4" screws and the control horn backplate.

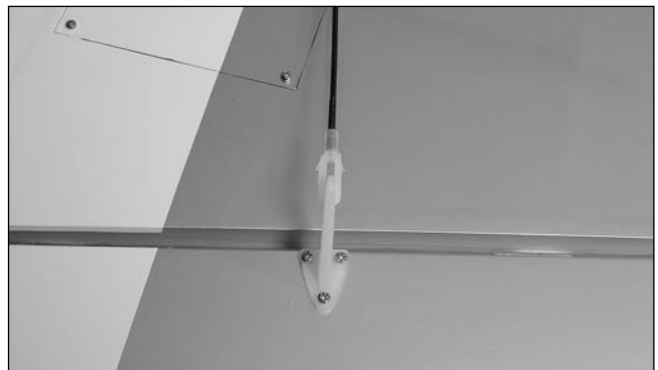

Section 13: Linkage Installation

Step 11

Slide a clevis retainer onto a nylon clevis. Thread a clevis onto a 6" wire a minimum of 10 turns. Center the aileron servo electronically using the radio system. Attach the pushrod with clevis to the control horn. Physically place the aileron control surface in neutral. Mark the pushrod where it crosses the holes in the servo arm.

Step 12

Bend the wire 90 degrees at the mark made in the previous step. Cut the wire 3/8" above the bend. Slide the wire through the outer hole in the aileron servo arm. Secure the wire using a nylon wire keeper.

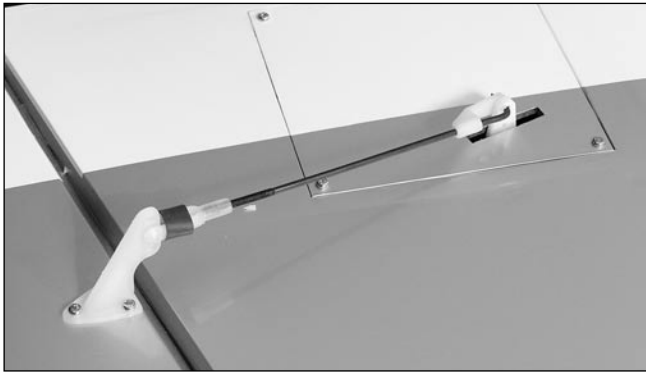

Step 13

Repeat Steps 9 through 12 for the other aileron servo.

Step 14

Use a 5/64" drill bit to drill a hole in the throttle servo arm.



Step 15

Attach a quick connector to the servo arm using quick connector washers and retainers. Center the throttle stick and trim with both the receiver and transmitter on. Install the throttle servo arm in the neutral position.

Step 16

Move the servo to the throttle open position using the radio system. Manually move the throttle arm on the carburetor to the open position. Use a 3mm setscrew to secure the throttle pushrod wire.



Step 17

Check the movement of the throttle to verify there is no binding at either low or high throttle. If there is, make the necessary adjustment to eliminate any binding. Install the throttle servo arm screw when complete.

Section 14: Cowling Installation

Required Parts

- Fuselage assembly
- Cowling
- #4 x 5/8" sheet metal screw (4)

Required Tools and Adhesives

- Drill
- Drill bit: 1/16", 1/8"
- Hobby scissors
- 6-minute epoxy
- Phillips screwdriver (small)
- Rotary tool with sanding drum

□ Step 1

Remove the center from the dummy radial engine to allow the engine drive washer to fit. Remove the areas between the cylinders to allow for cooling air to the engine.



□ Step 2

Use 30-minute epoxy to glue the dummy radial engine into the cowling. Use care to make sure the radial is positioned an even distance from the front edge of the cowling.



□ Step 3

Glue the 5/8" x 13/16" x 13/16" cowl blocks to the firewall using 30-minute epoxy. The blocks should be placed evenly around the firewall perimeter.

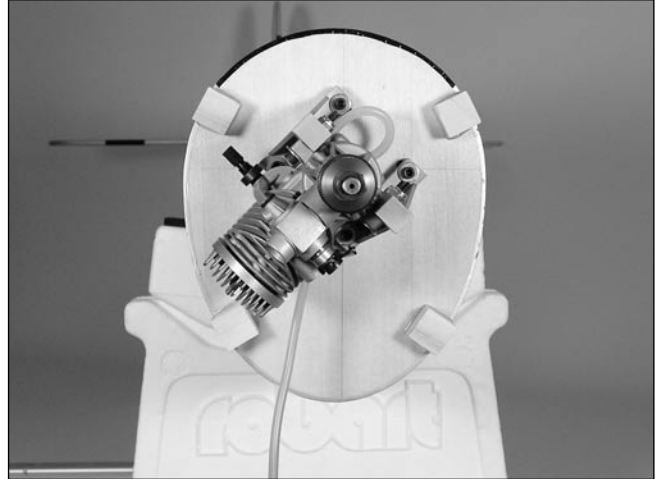

□ Step 4

Test fit the cowling onto the fuselage. Remove any material necessary to clear the various engine components. The cowl is positioned so the drive washer from the engine is 1/8" forward of the front edge of the dummy radial.



Section 14: Cowling Installation

□ Step 5

Use pieces of card stock to mark the locations for the cowl mounting blocks and any other engine items that may not have been trimmed in Step 4. Mark the locations of these items onto the cowl using a felt-tipped pen.



□ Step 6

Drill the locations for the cowl mounting screws using a 1/8" drill. Drill the mounting blocks using a 5/64" drill. Mount the cowl using four #4 x 5/8" sheet metal screws. Be sure to drill the hole to access the glow plug. We also added a Hangar 9 Fuel Filler (HAN115) to allow easy filling of the fuel tank..

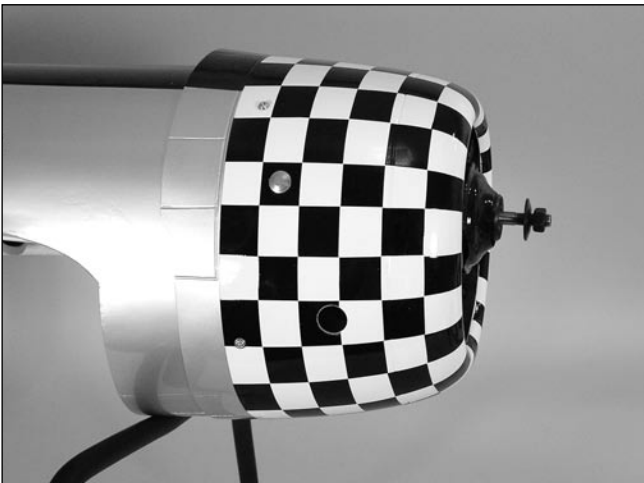

□ Step 7

Install the propeller using the instructions provided by the engine manufacturer.

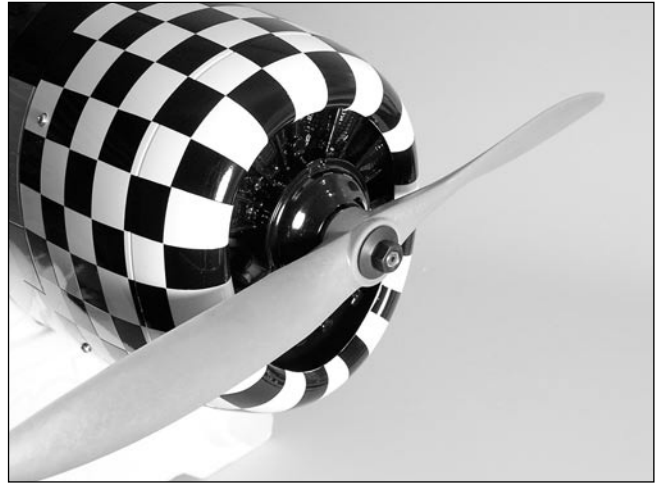

Note: The cover model is shown with a Tru-Turn 1 1/4" A-Style prop hub (TRUB1250A). It also requires a propeller adapter for your specific engine.

Section 15: Canopy and Decal Installation

Required Parts

- Fuselage assembly
- Canopy

Required Tools and Adhesives

- Canopy glue (RC-56)
- Sandpaper (medium grit)
- Zap-A-Dap-A-Goo
- Hangar 9™ 1/7th scale WWII pilot (HAN8311) (Optional)

Step 1

Install a pilot of your choosing. Use epoxy or Zap-A-Dap-A-Goo to secure the pilot. Use Lexan scissors to trim the backrest. Use Zap-A-Dap-A-Goo to glue the backrest into position. Install the instrument panel decal as well.



Step 2

Use Lexan scissors to trim the canopy.



Step 3

Position the canopy onto the fuselage. Trace around the canopy and onto the fuselage using a felt-tipped pen.

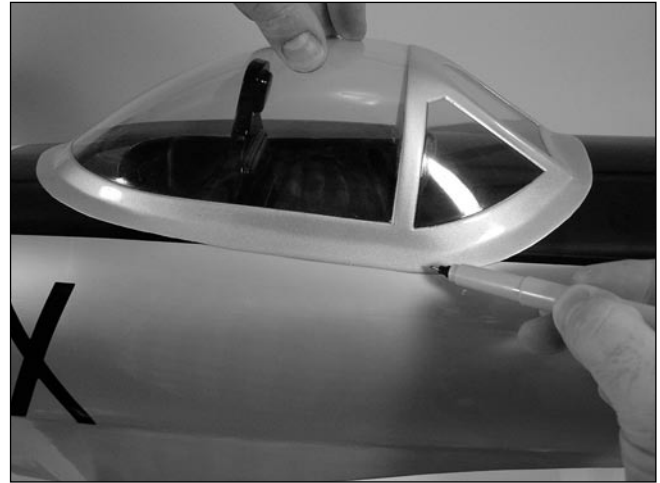

Step 4

Lightly sand the inside edge of the canopy and slightly inside the line drawn on the hatch using medium sandpaper.

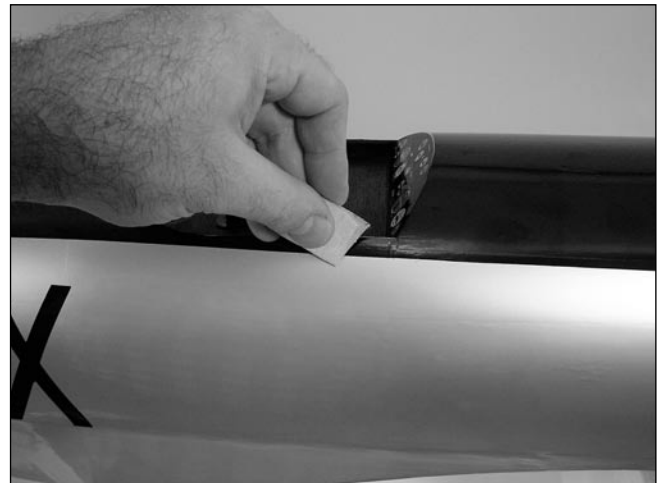

Section 15: Canopy and Decal Installation

Step 5

Apply a bead of RCZ56 Canopy Glue (ZINJ5007) around the inside edge of the canopy. Position the canopy onto the hatch. Use tape to hold the canopy secure until the glue fully cures.

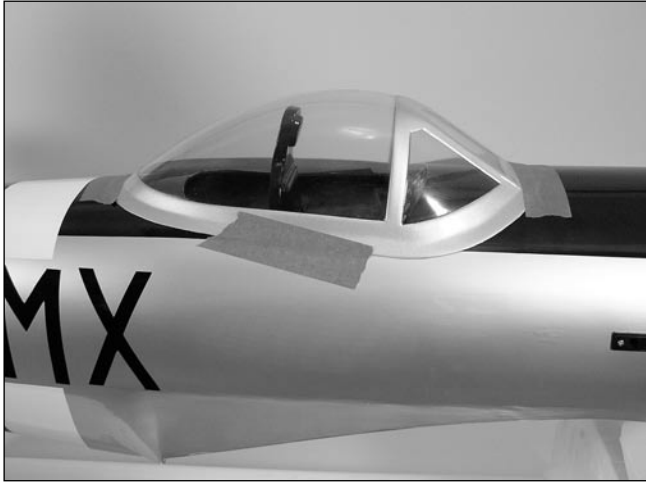

Step 6

Apply the decals. Use the photos on the box to aid in their location.

Adjusting the Engine

Step 1

Completely read the instructions included with your engine and follow the recommended break-in procedure.

Step 2

At the field, adjust the engine to a slightly rich setting at full throttle and adjust the idle and low-speed needle so that a consistent idle is achieved.

Step 3

Before you fly, be sure that your engine idles reliably, transitions and runs at all throttle settings. Only when this is achieved should any plane be considered ready for flight.

Preflight

Charge both the transmitter and receiver pack for your airplane. Use the recommended charger supplied with your particular radio system, following the instructions provided with the radio. In most cases the radio should be charged the night before going out flying.

Check the radio installation and make sure all the control surfaces are moving correctly (i.e. the correct direction and with the recommended throws). Test run the engine and make sure it transitions smoothly from idle to full throttle and back. Also ensure the engine is tuned according to the manufacturers instructions, and it will run consistently and constantly at full throttle when adjusted.

Check all the control horns, servo horns and clevises to make sure they are secure and in good condition. Replace any items that would be considered questionable. Failure of any of these components in flight would mean the loss of your aircraft.

Control Throws

The amount of control throw should be adjusted as closely as possible using mechanical means, rather than making large changes electronically at the radio. By moving the position of the clevis at the control horn toward the outermost hole, you will decrease the amount of control throw of the control surface. Moving it toward the control surface will increase the amount of throw. Moving the pushrod wire at the servo arm will have the opposite effect: Moving it closer to center will decrease throw, and away from center will increase throw. Work with a combination of the two to achieve the closest or exact control throws listed.

	Low Rate	High Rate
Aileron	1/2" Up/Down 14° Up/Down	11/16" Up/Down 20° Up/Down
Elevator	9/16" Up/Down 10° Up/Down	13/16" Up/Down 15° Up/Down
Rudder	1 3/16" Left/Right 20° Right/Left	1 3/8" Left/Right 26° Right/Left

Note: Control throws are measured at the widest part of the elevator, rudder, and aileron unless noted otherwise.

Recommended CG

An important part of preparing the aircraft for flight is properly balancing the model. This is especially important when various engines are mounted.

Caution: Do not inadvertently skip this step!

The recommended Center of Gravity (CG) location for the P-47 is 4.5" behind the leading edge of the wing against the fuselage. Make sure the gear is retracted when checking the CG, as the CG will change depending on the gear position. If necessary, move the battery pack or add weight to either the nose or the tail until the correct balance is achieved. Stick-on weights are available at your local hobby shop and work well for this purpose.

Range Testing the Radio

Before each flying session, range-check your radio. This is accomplished by turning on your transmitter with the antenna collapsed. Turn on the radio in your airplane. With your airplane on the ground, you should be able to walk 30 paces away from your airplane and still have complete control of all functions. If not, don't attempt to fly! Have your radio equipment checked out by the manufacturer.

2005 Official AMA National Model Aircraft Safety Code

GENERAL

- 1) I will not fly my model aircraft in sanctioned events, air shows or model flying demonstrations until it has been proven to be airworthy by having been previously, successfully flight tested.
- 2) I will not fly my model higher than approximately 400 feet within 3 miles of an airport without notifying the airport operator. I will give right-of-way and avoid flying in the proximity of full-scale aircraft. Where necessary, an observer shall be utilized to supervise flying to avoid having models fly in the proximity of full-scale aircraft.
- 3) Where established, I will abide by the safety rules for the flying site I use, and I will not willfully and deliberately fly my models in a careless, reckless and/or dangerous manner.
- 4) The maximum takeoff weight of a model is 55 pounds, except models flown under Experimental Aircraft rules.
- 5) I will not fly my model unless it is identified with my name and address or AMA number, on or in the model. (This does not apply to models while being flown indoors.)
- 6) I will not operate models with metal-bladed propellers or with gaseous boosts, in which gases other than air enter their internal combustion engine(s); nor will I operate models with extremely hazardous fuels such as those containing tetranitromethane or hydrazine.

- 7) I will not operate models with pyrotechnics (any device that explodes, burns, or propels a projectile of any kind) including, but not limited to, rockets, explosive bombs dropped from models, smoke bombs, all explosive gases (such as hydrogen-filled balloons), or ground mounted devices launching a projectile. The only exceptions permitted are rockets flown in accordance with the National Model Rocketry Safety Code or those permanently attached (as per JATO use); also those items authorized for Air Show Team use as defined by AST Advisory Committee (document available from AMA HQ). In any case, models using rocket motors as a primary means of propulsion are limited to a maximum weight of 3.3 pounds and a G series motor. (A model aircraft is defined as an aircraft with or without engine, not able to carry a human being.)
- 8) I will not consume alcoholic beverages prior to, nor during, participation in any model operations.
- 9) Children under 6 years old are only allowed on the flight line as a pilot or while receiving flight instruction.

RADIO CONTROL

- 1) I will have completed a successful radio equipment ground range check before the first flight of a new or repaired model.
- 2) I will not fly my model aircraft in the presence of spectators until I become a qualified flier, unless assisted by an experienced helper.
- 3) At all flying sites a straight or curved line(s) must be established in front of which all flying takes place with the other side for spectators. Only personnel involved with flying the aircraft are allowed at or in the front of the flight line. Intentional flying behind the flight line is prohibited.
- 4) I will operate my model using only radio control frequencies currently allowed by the Federal Communications Commission. (Only properly licensed Amateurs are authorized to operate equipment on Amateur Band frequencies.)

2005 Official AMA National Model Aircraft Safety Code

- 5) Flying sites separated by three miles or more are considered safe from site-to site interference, even when both sites use the same frequencies. Any circumstances under three miles separation require a frequency management arrangement, which may be either an allocation of specific frequencies for each site or testing to determine that freedom from interference exists. Allocation plans or interference test reports shall be signed by the parties involved and provided to AMA Headquarters. Documents of agreement and reports may exist between (1) two or more AMA Chartered Clubs, (2) AMA clubs and individual AMA members not associated with AMA Clubs, or (3) two or more individual AMA members.
- 6) For Combat, distance between combat engagement line and spectator line will be 500 feet per cubic inch of engine displacement. (Example: .40 engine = 200 feet.); electric motors will be based on equivalent combustion engine size. Additional safety requirements will be per the RC Combat section of the current Competition Regulations.
- 7) At air shows or model flying demonstrations, a single straight line must be established, one side of which is for flying, with the other side for spectators.
- 8) With the exception of events flown under AMA Competition rules, after launch, except for pilots or helpers being used, no powered model may be flown closer than 25 feet to any person.
- 9) Under no circumstances may a pilot or other person touch a powered model in flight.

Organized RC Racing Event

- 10) An RC racing event, whether or not an AMA Rule Book event, is one in which model aircraft compete in flight over a prescribed course with the objective of finishing the course faster to determine the winner.
- A. In every organized racing event in which contestants, callers and officials are on the course:
1. All officials, callers and contestants must properly wear helmets, which are OSHA, DOT, ANSI, SNELL or NOCSAE approved or comparable standard while on the racecourse.
 2. All officials will be off the course except for the starter and their assistant.
 3. "On the course" is defined to mean any area beyond the pilot/staging area where actual flying takes place.
- B. I will not fly my model aircraft in any organized racing event which does not comply with paragraph A above or which allows models over 20 pounds unless that competition event is AMA sanctioned.
- C. Distance from the pylon to the nearest spectator (line) will be in accordance with the current Competition Regulations under the RC Pylon Racing section for the specific event pending two or three pylon course layout.
- 11) RC night flying is limited to low-performance models (less than 100 mph). The models must be equipped with a lighting system that clearly defines the aircraft's attitude at all times.

HANGAR 9™

HORIZON
H O B B Y

© 2005 Horizon Hobby, Inc.
4105 Fieldstone Road
Champaign, Illinois 61822
(877) 504-0233
horizonhobby.com