

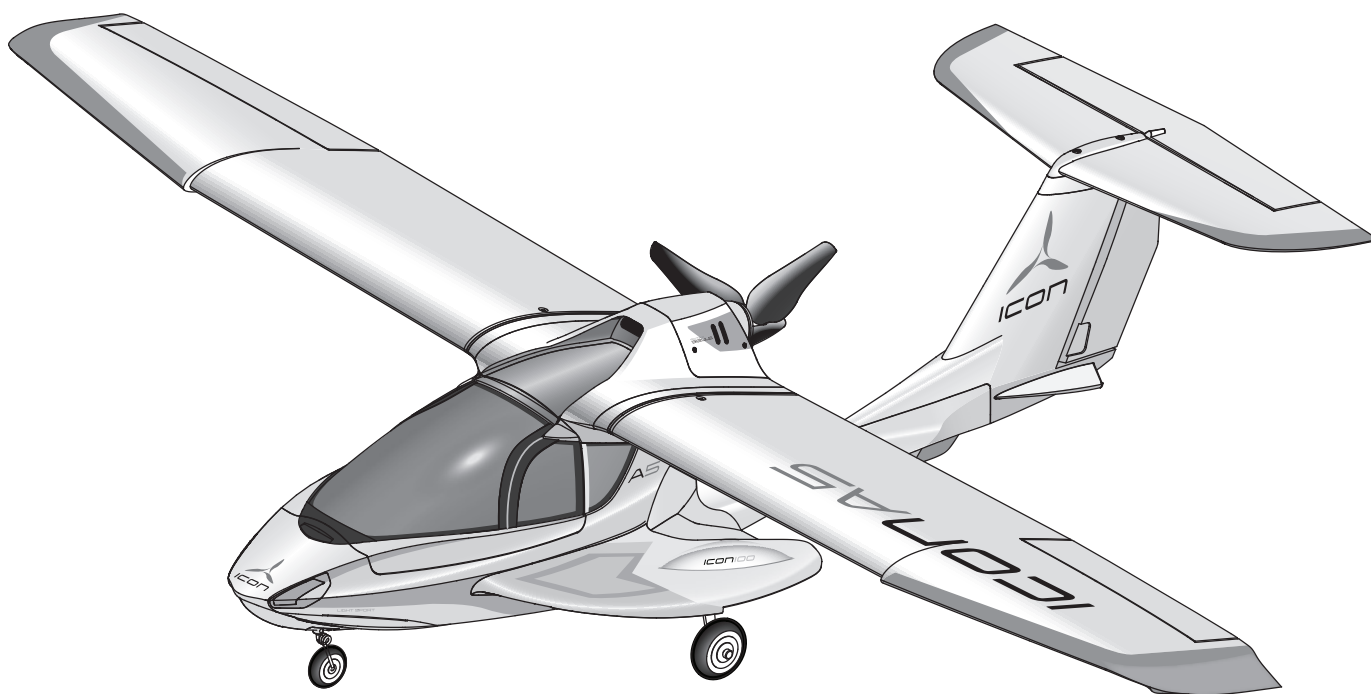

ICON A5

Instruction Manual • Bedienungsanleitung • Manuel d'utilisation • Manuale di Istruzioni



ICON, the ICON logo, ICON A5 and its body design are trademarks or registered trademarks of ICON Aircraft, Inc. and are used with permission by Horizon Hobby, Inc.



Bind-N-Fly.® Ready to fly. redefined.



NOTICE

All instructions, warranties and other collateral documents are subject to change at the sole discretion of Horizon Hobby, Inc. For up-to-date product literature, visit www.horizonhobby.com and click on the support tab for this product.

Meaning of Special Language:

The following terms are used throughout the product literature to indicate various levels of potential harm when operating this product:

NOTICE: Procedures, which if not properly followed, create a possibility of physical property damage AND little or no possibility of injury.

CAUTION: Procedures, which if not properly followed, create the probability of physical property damage AND a possibility of serious injury.

WARNING: Procedures, which if not properly followed, create the probability of property damage, collateral damage, and serious injury OR create a high probability of superficial injury.



WARNING: Read the ENTIRE instruction manual to become familiar with the features of the product before operating. Failure to operate the product correctly can result in damage to the product, personal property and cause serious injury.

This is a sophisticated hobby product. It must be operated with caution and common sense and requires some basic mechanical ability. Failure to operate this Product in a safe and responsible manner could result in injury or damage to the product or other property. This product is not intended for use by children without direct adult supervision. Do not attempt disassembly, use with incompatible components or augment product in any way without the approval of Horizon Hobby, Inc. This manual contains instructions for safety, operation and maintenance. It is essential to read and follow all the instructions and warnings in the manual, prior to assembly, setup or use, in order to operate correctly and avoid damage or serious injury.

Additional Safety Precautions and Warnings

As the user of this product, you are solely responsible for operating in a manner that does not endanger yourself and others or result in damage to the product or the property of others.

Age Recommendation: Not for children under 14 years. This is not a toy.

- This model is controlled by a radio signal subject to interference from many sources outside your control. Interference can cause momentary loss of control, so it is advisable to always keep a safe distance in all directions around your mode as this margin will help avoid collisions or injury.
- Always operate your model in open spaces away from full-size vehicles, traffic and people.
- Always carefully follow the directions and warnings for this and any optional support equipment (chargers, rechargeable battery packs, etc.).
- Always keep all chemicals, small parts and anything electrical out of the reach of children.
- Always avoid water exposure to all equipment not specifically designed and protected for this purpose. Moisture causes damage to electronics.
- Never place any portion of the model in your mouth as it could cause serious injury or even death.
- Never operate your model with low transmitter batteries.

Battery Warnings

The Battery Charger included with your aircraft is designed to safely charge the Li-Po battery.

CAUTION: All instructions and warnings must be followed exactly. Mishandling of Li-Po batteries can result in a fire, personal injury, and/or property damage.

- By handling, charging or using the included Li-Po battery, you assume all risks associated with lithium batteries.
- If at any time the battery begins to balloon or swell, discontinue use immediately. If charging or discharging, discontinue and disconnect. Continuing to use, charge or discharge a battery that is ballooning or swelling can result in fire.
- Always store the battery at room temperature in a dry area for best results.
- Always transport or temporarily store the battery in a temperature range of 40–120° F. Do not store battery or model in a car or direct sunlight. If stored in a hot car, the battery can be damaged or even catch fire.
- NEVER USE A Ni-Cd OR Ni-MH CHARGER. Failure to charge the battery with a compatible charger may cause fire resulting in personal injury and/or property damage.
- Never discharge Li-Po cells to below 3V under load.
- Never cover warning labels with hook and loop strips.
- Never leave charging batteries unattended.
- Never charge batteries outside safe temperature range.
- Never charge damaged batteries.

Welcome to the world of amphibious RC flight! Even if this isn't your first float plane experience, you're in for some of the most fun you will ever have flying off the water. Not only is the ParkZone® ICON A5 a licensed replica of the most exciting light sport airplane in general aviation, it was actually designed with the assistance of the ICON Aircraft Company. As a result, it boasts a near-perfect scale outline and a special hull design that makes water takeoffs and landings remarkably easy to master. Before you take that first flight though, you must read this manual thoroughly. In addition to step-by-step assembly instructions, it contains important preflight and setup tips as well as a handy troubleshooting guide. It's all here to make sure your first flight, and every one after, is as rewarding as can be.

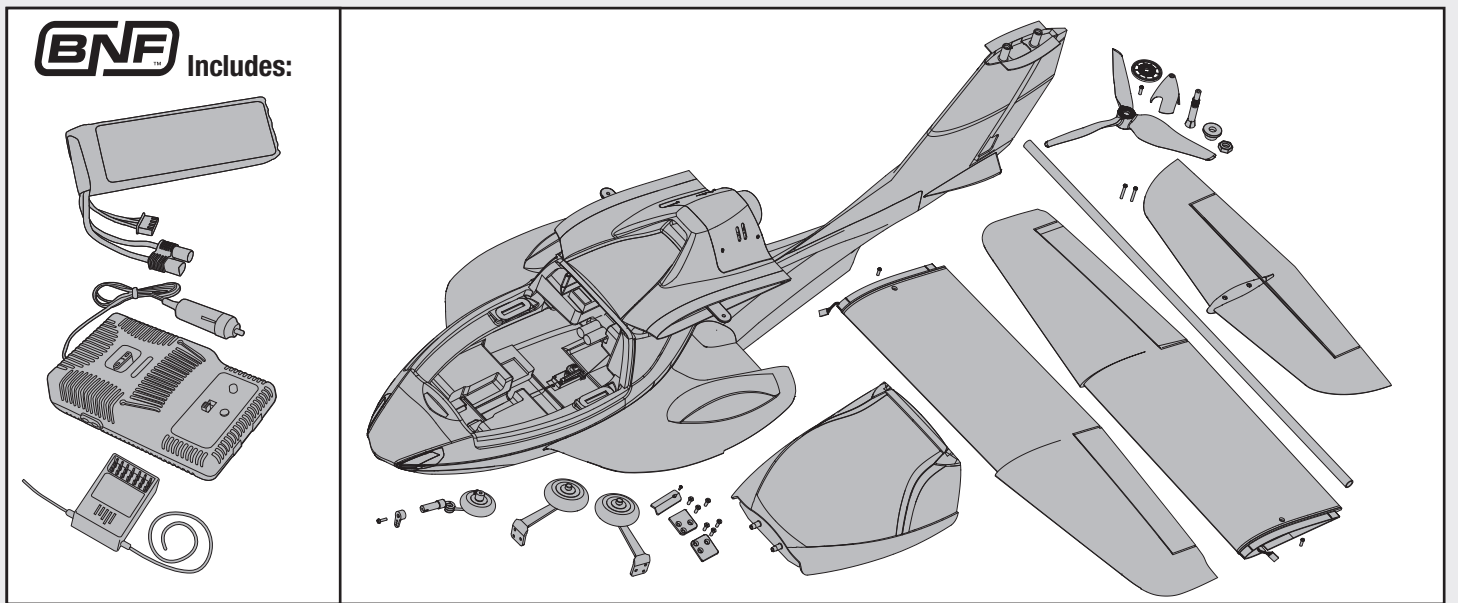
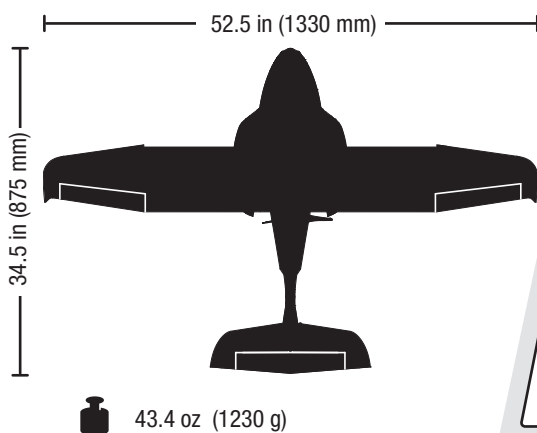

Table of Contents

Battery Warnings	2	Control Direction Test	10
Charging the Flight Battery	4	Dual Rates	11
Low Voltage Cutoff (LVC)	4	Service of Power Components	11
Transmitter and Receiver Binding	5	Optional Headlights	11
Installing Battery	5	Flying Tips and Repairs	12
Before Flight	6	First Flight Preparation	12
Installing a Receiver	6	Maintenance After Flying	12
Battery Selection and Installation	6	AMA National Model Aircraft Safety Code	13
Installing Wing	7	Troubleshooting Guide	14
Installing Horizontal Tail	7	Warranty and Repair Policy	15
Installing Propeller	8	Contact Information	16
Landing Gear (Runway takeoff and landing)	8	Compliance Information for the European Union	16
Fuselage Gear Covers Installation (Water takeoff and landing)	9	Parts Contact Information	59
Installing Clevises on Control Horns and Control Centering	9	Replacement Parts	59
Factory Settings	9	Optional Parts	60
Center of Gravity (CG)	9		

Specifications



Bind-N-Fly® Aircraft	Plug-N-Play® Aircraft
Installed	Installed 480-sized 960Kv brushless outrunner
Installed	Installed EFL 30A Pro SB brushless ESC
Installed	Installed (4) Servos
Installed	Needed to Complete Recommended Receiver: Spektrum™ DSM2™ or DSMX® full-range or park flyer sport receiver
Included	Needed to Complete Battery: 2200mAh 3S 25C Li-Po Battery Charger: .3A-2.0A, 2-3 cell balancing Li-Po battery charger
Needed to Complete	Needed to Complete Recommended Transmitter: Full-Range 2.4GHz with Spektrum™ DSM2™/DSMX® technology.

To register your product online, visit www.parkzone.com



Charging the Flight Battery

Your ICON A5 comes with a DC balancing charger and 3S Li-Po battery. You should only charge the battery with the included charger. Never leave the battery and charger unattended during the charge process. Failure to follow the instructions properly could result in a fire. When charging, make certain the battery is on a heat-resistant surface. Charge the flight battery while assembling the aircraft. Install the fully charged battery to perform control tests and binding.

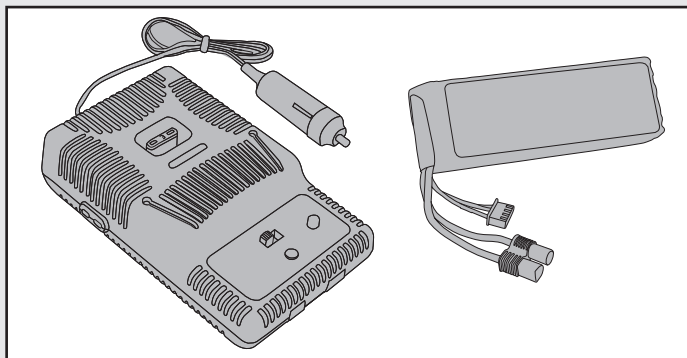

DC Li-Po Balancing Charger Features

- Charges 2- to 3-cell lithium polymer battery packs
- Variable charge rates from 300mAh to 2-amp
- Simple single push-button operation
- LED charge status indicator
- LED cell balance indicator
- Audible beeper indicates power and charge status
- 12V accessory outlet input cord

Specifications

- Input power: 12V DC, 3-amp
- Charges 2- to 3-cell Li-Po packs with minimum capacity of 300mAh

3S 11.1V 2200mAh 25C Li-Po Battery Pack (PKZ1029)

The ParkZone® 3S Li-Po battery pack features a balancing lead that allows you to safely charge your battery pack when used with the included ParkZone Li-Po balancing charger.



CAUTION: The balance connector **must** be inserted into the correct port of your charger prior to charging.

The Battery Charging Process

1. Charge only batteries that are cool to the touch and are not damaged. Look at the battery to make sure it is not damaged e.g., swollen, bent, broken or punctured.
2. Attach the input cord of the charger to the appropriate power supply (12V accessory outlet).
3. When the Li-Po charger has been correctly powered up, there will be an approximate 3-second delay, then an audible “beep” and the green (ready) LED will flash.
4. Turn the control on the Amps selector so the arrow points to the charging rate required for the Battery (the ICON A5 2200mAh Li-Po battery will charge at 2.0 amps). DO NOT change the charge rate once the battery begins charging.
5. Move the cell selector switch to 3-cell for your battery.
6. Connect the Balancing Lead of the Battery to the 3-cell (it has 4 pins) charger port.
7. The green and red LEDs may flash during the charging process when the charger is balancing cells. Balancing prolongs the life of the battery.
8. When the battery is fully charged, there will be an audible beep for about 3 seconds and the green LED will shine continuously. Attempting to charge an over-discharged battery will cause the charger to repeatedly flash and beep, indicating an error has occurred.
9. Always unplug the battery from the charger immediately upon completion of charging.



CAUTION: Overcharging a battery can cause a fire.



CAUTION: Only use a charger specifically designed to charge a Li-Po battery. Failure to do so could result in fire causing injury or property damage.



CAUTION: Never exceed the recommended charge rate.

NOTICE: If using a battery other than the included Li-Po battery, refer to your battery manufacturer's instructions for charging.

Low Voltage Cutoff (LVC)

When a Li-Po battery is discharged below 3V per cell, it will not hold a charge. The ESC protects the flight battery from over-discharge using Low Voltage Cutoff (LVC). Before the battery charge decreases too much, LVC removes power supplied to the motor. Power to the motor pulses, showing that some battery power is reserved for flight control and safe landing.

When the motor pulses, land the aircraft immediately and recharge the flight battery. Disconnect and remove the Li-Po battery from the aircraft after use to prevent trickle discharge. Fully charge your Li-Po battery before storing it. During storage, make sure battery charge does not go below 3V per cell.



Transmitter and Receiver Binding

Binding is the process of programming the receiver of the control unit to recognize the GUID (Globally Unique Identifier) code of a single specific transmitter. You need to 'bind' your chosen Spektrum™ DSM2™/DSMX® technology equipped aircraft transmitter to the receiver for proper operation.

Please visit www.bindnfly.com for a complete list of compatible transmitters.

NOTICE: When using a Futaba transmitter with a Spektrum DSM® module, you must reverse the throttle channel.

BIND PLUG



✓ Binding Procedure Reference Table

1.	Read the transmitter instructions for binding to a receiver (location of transmitter's Bind control).
2.	Make sure the transmitter is powered off.
3.	Move the transmitter controls to neutral and throttle position to low (including throttle trim).*
4.	Install a bind plug in the receiver bind port.
5.	Connect the flight battery to the ESC.
6.	The receiver LED will begin to flash rapidly.
7.	Power on the transmitter while holding the transmitter bind button or switch. Refer to your transmitter's manual for binding button or switch instructions.
8.	When the receiver binds to the transmitter, the light on the receiver will be solid and the ESC will produce a series of sounds. The series of sounds is a long tone, then three short tones that confirm the LVC is set for the ESC.
9.	Remove the bind plug from the bind port.
10.	Safely store the bind plug (some owners attach the bind plug to their transmitter using two-part loops and clips).
11.	The receiver should retain the binding instructions received from the transmitter until another binding is done.

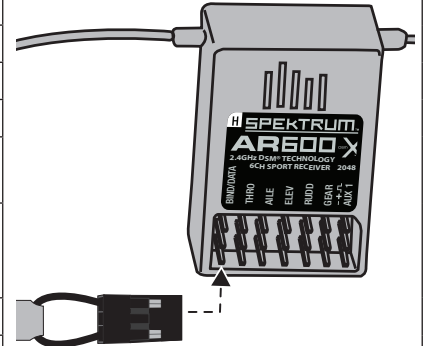

* The throttle will not arm if the transmitter's throttle control is not at the lowest position. If you encounter problems, follow binding instructions and refer to the transmitter troubleshooting guide for other instructions. If needed, contact the appropriate Horizon Product Support office.

Installing Battery

1. Carefully lift the back of the canopy hatch (A) and pull hatch pins from the holes in the fuselage to remove the hatch.
2. Install flight battery (B) all the way to the front of the battery compartment, making certain that it does not bind on the nose wheel steering.
3. Connect battery connector to the ESC power connector.
4. Make sure the flight battery (B) is held tight using a hook and loop strap (C).
5. Install canopy hatch on fuselage. Make sure the magnets on the hatch and fuselage touch.

⚠ CAUTION: Always disconnect the Li-Po battery from the aircraft receiver when not flying to avoid over-discharging the battery. Batteries discharged to a voltage lower than the lowest approved voltage may be damaged, resulting in loss of performance and potential fire when batteries are charged.

⚠ CAUTION: Always keep hands away from the propeller. When armed, the motor will turn the propeller in response to any throttle movement.

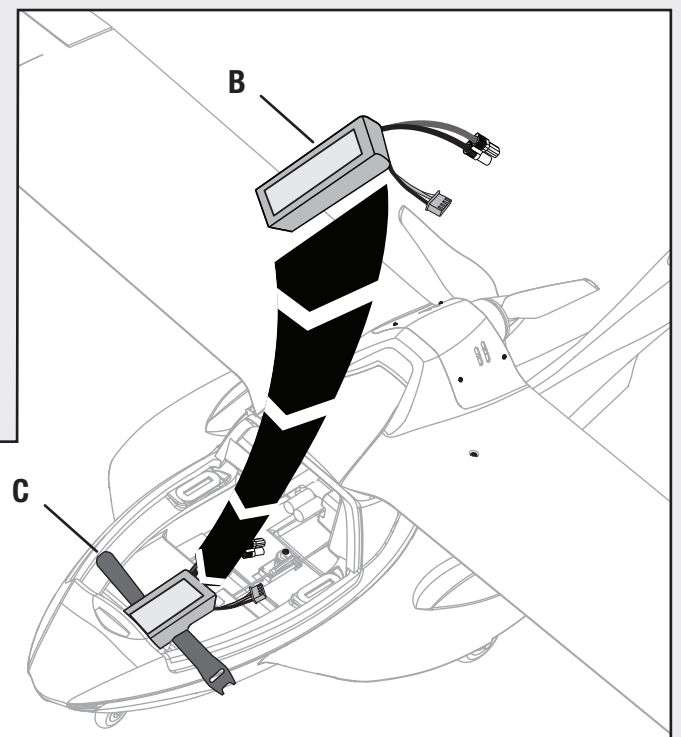
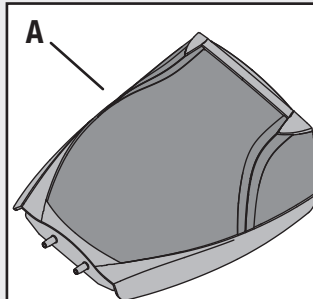

Before Flight

1



• Lower throttle and throttle trim to lowest settings.

2

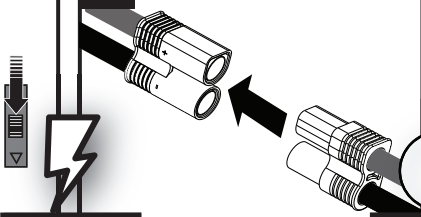

Power on Transmitter

• Connect battery to ESC.

3

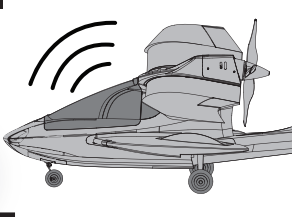

Wait 5 seconds

Continuous LED
Series of tones

PNP
PLUG-N-PLAY™

Installing a Receiver

1. Remove the canopy hatch to install a receiver.
2. Install your parkflyer or full-range receiver on a shelf on the right side in the fuselage using hook and loop tape or double-sided servo tape.
3. Attach the elevator and rudder servo connectors to the appropriate channels of the receiver.
4. Attach the aileron Y-harness to the aileron channel of the receiver.
5. Attach the ESC connector to the throttle channel of the receiver.

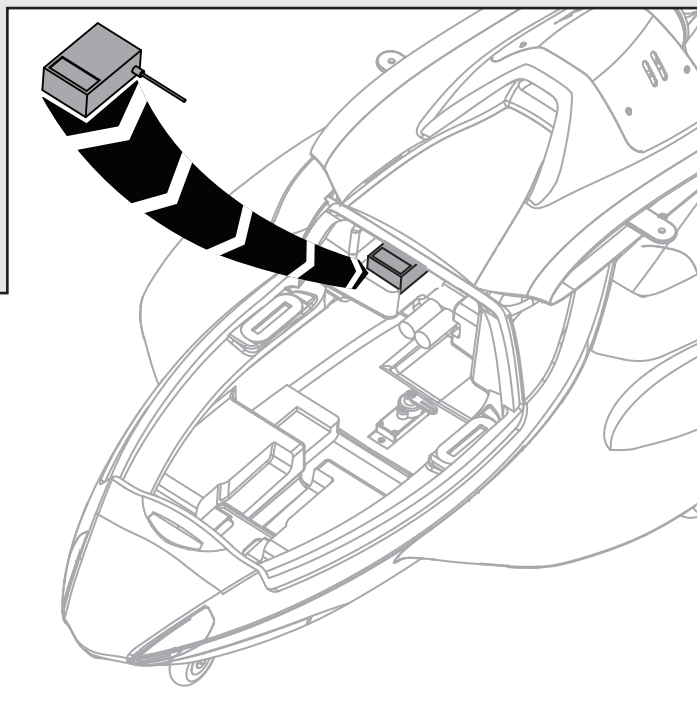
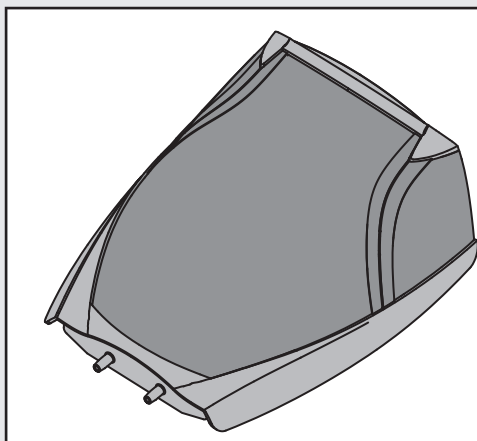

Battery Selection and Installation

1. We recommend the ParkZone 2200mAh 11.1V 25C Li-Po battery (PKZ1029).
2. If using another battery, the battery must be at least a 25C 2100mAh battery.
3. Your battery should be approximately the same capacity, dimensions and weight as the ParkZone Li-Po battery to fit in the fuselage without changing the center of gravity.

Installing Wing

1. Put the wing tube (A) into the hole in the wing slot of the fuselage.
2. Put the right wing on the wing tube.
3. Move the wing on the tube into the slot on the fuselage while putting the aileron connector in the fuselage.
4. Attach the two aileron connectors to the aileron Y-harness at the root of each wing. Place extra servo lead slack and servo connectors in the small cavity in the root of the wing.
5. Fully install the right wing on the fuselage using a screw (B).
6. Install the left wing using the steps above.

⚠ CAUTION: Do NOT crush or otherwise damage wiring when attaching wing to fuselage.

7. Where needed, disassemble in reverse order.

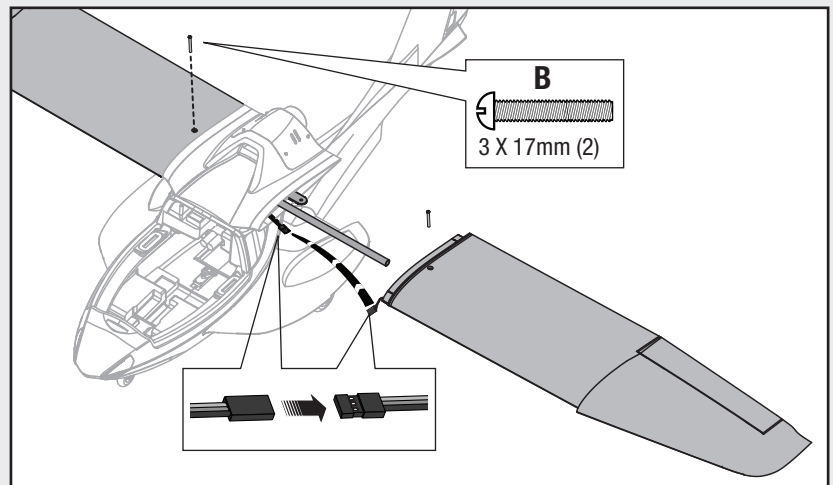
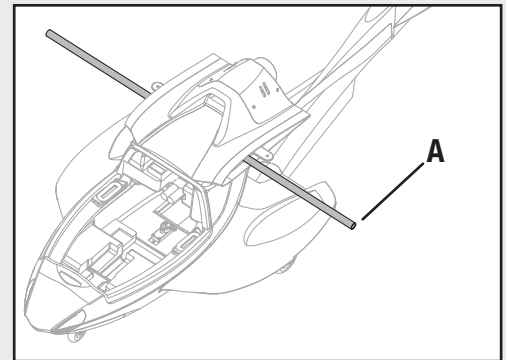

Installing Horizontal Tail

1. Install the horizontal tail on the fuselage using the two screws (A).
2. Attach the clevis to the elevator control horn (see instructions for clevis connection).
3. When needed, disassemble in reverse order.

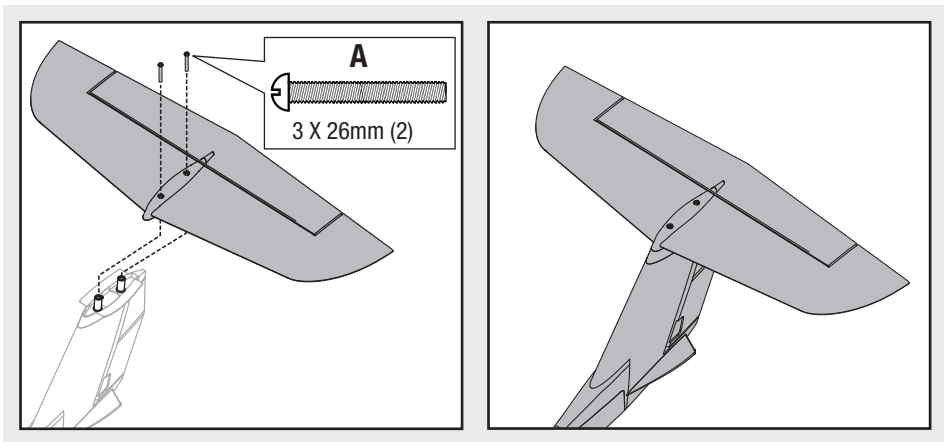

Installing Propeller

1. Install the collet (A) on the motor shaft (B).
2. Install the backplate (C), spinner backplate (D), propeller (E) and spinner nut (F) on the collet shaft. Use a tool to tighten the spinner nut on the collet shaft.
3. Install the spinner (G) on the spinner nut (F) using a screw (H). Make sure the spinner is tight on the spinner backplate.

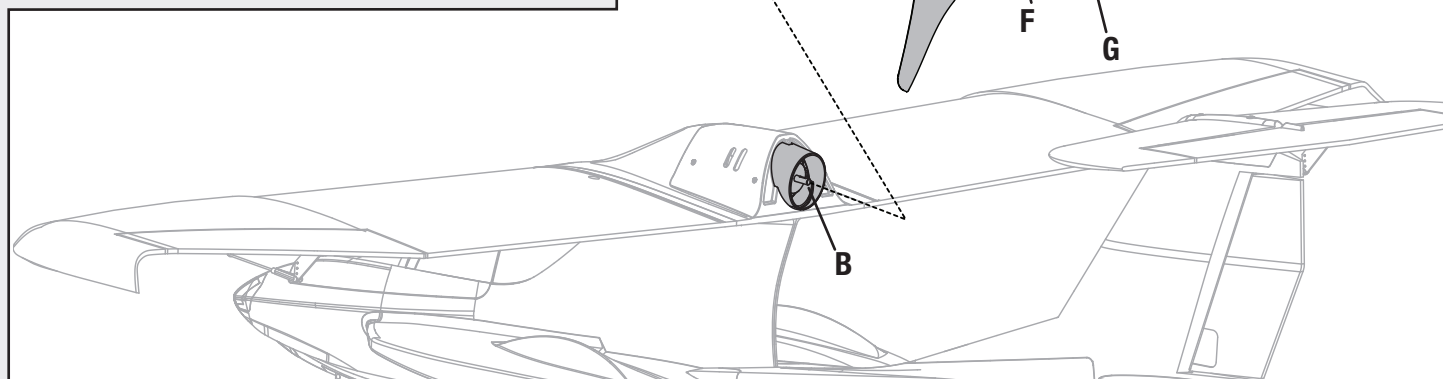

Installing Landing Gear (Runway takeoff and landing)

Main Gear Installation

1. Turn the model over so the bottom faces up.
2. Install the rear right and left landing gear struts (A) in the fuselage using six screws (B).

Nose Gear Installation

1. Install the nose wheel post in the hole in front of the fuselage.
2. Put the Z-bend of the steering linkage (C) in the outermost hole of the steering arm (D).
3. Carefully turn over the model so it rests on the landing gear. Put the end of the steer linkage under the battery compartment inside the fuselage.
4. Align the steering arm with top of the nose wheel post so the arm is oriented as shown.
5. Install screw (E) to hold the arm on top of the nose wheel post.
6. Connect the linkage clevis (behind the battery compartment) to the rudder servo arm. See Factory Settings for an illustration of the linkages on the servo arms.

NOTICE: Always ensure the steering linkage clevis is adjusted correctly to make the model steer straight when the rudder control is at neutral.

If disassembled, install wheels on the rear struts using shoulder screws, washers and nuts. Make sure the bushing side of the wheels are toward the struts. Use a small amount of threadlock to hold the nut on the shoulder screw. Use a small amount of threadlock on the setscrew in the wheel collar on the nose wheel.

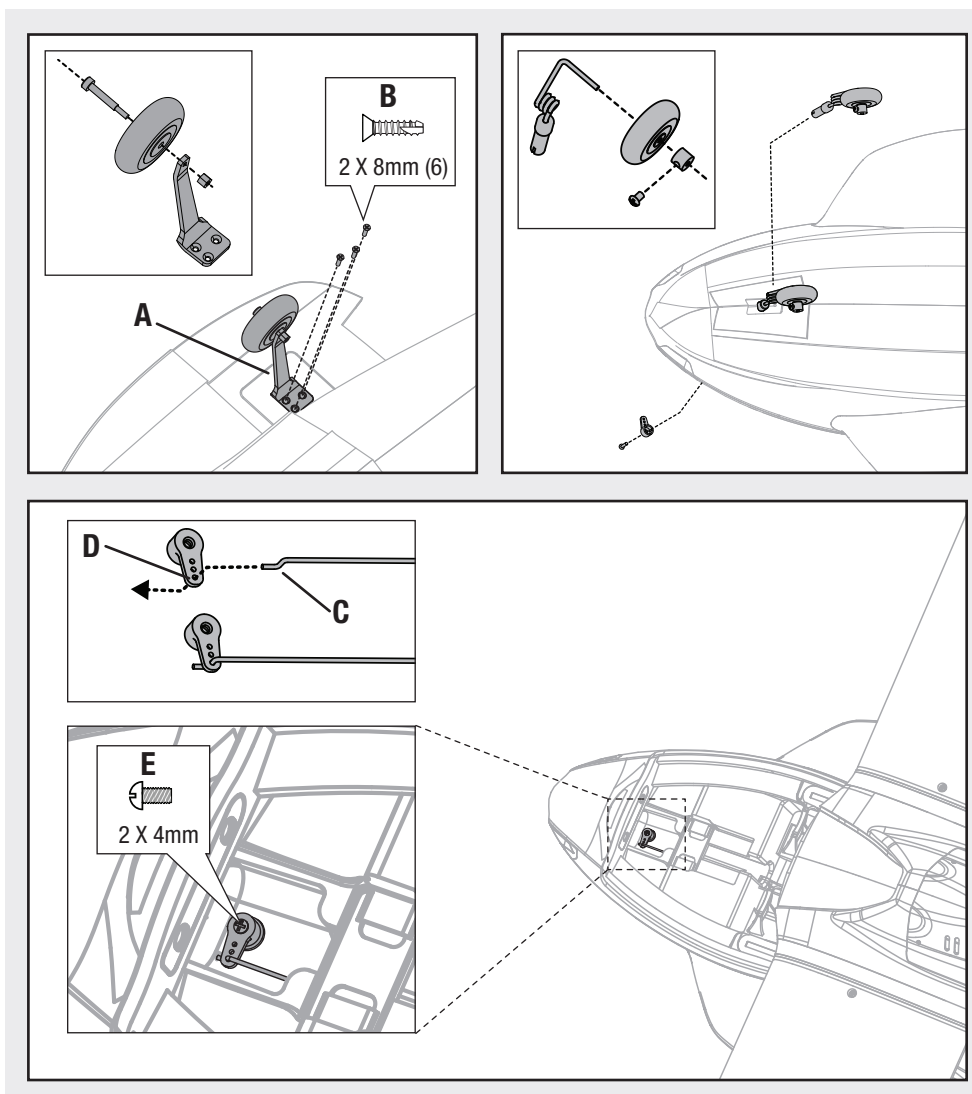

Installing Fuselage Gear Covers (Water takeoff and landing)

1. Cover the nose gear hole with the nose plate using a screw (A).
2. Install the left and right rear gear covers (marked L and R) using six screws (B).

NOTICE: When removing or installing the nose plate, ensure the O-ring is not damaged or lost.

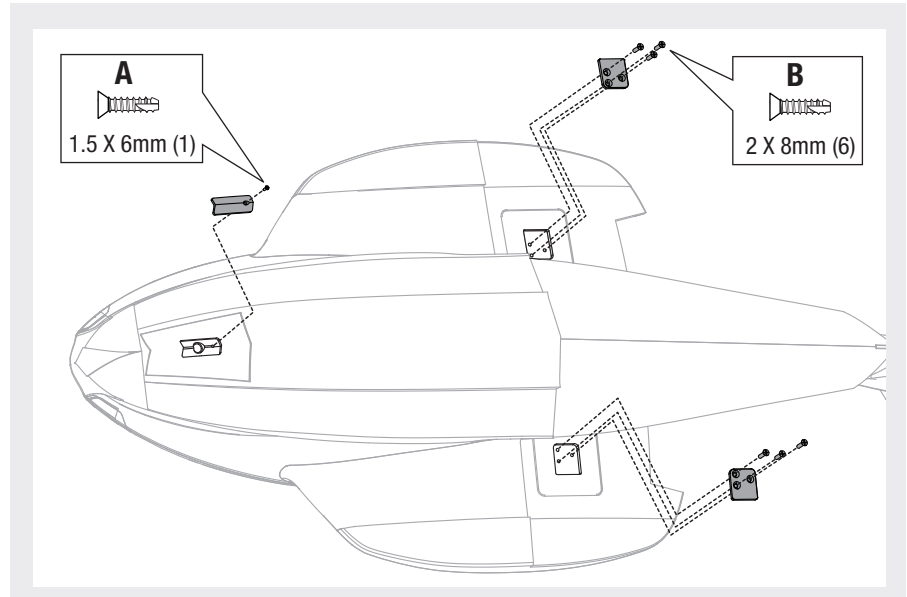

Installing Clevises on Control Horns and Control Centering

Tip: Turn the clevis clockwise or counterclockwise on the linkage.

- Pull the tube from the clevis to the linkage.
- Carefully spread the clevis and put the clevis pin into the desired control horn.
- Move the tube to tighten the clevis onto the control horn.

After binding a transmitter to the model receiver, set trims and sub-trims to 0, then adjust clevises to center the control surfaces.

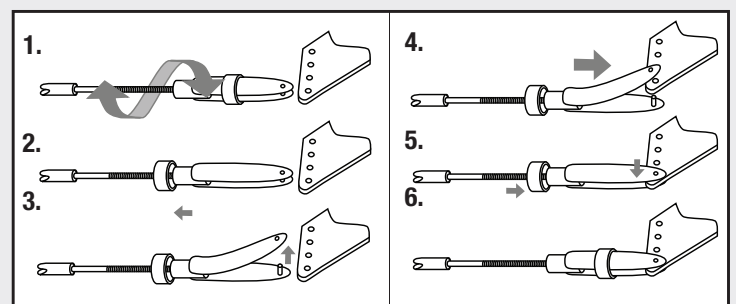

Factory Settings

Fly the model at factory settings before making changes. For pilots who wish for more control throw, adjust the position of the linkages on the servo arms and control horns for increased travel.

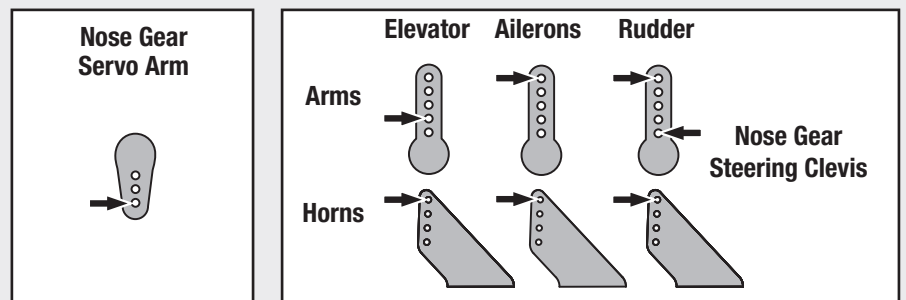

Center of Gravity (CG)

Start with the battery all the way forward in the fuselage and hold the battery in place using a hook and loop strap. It is easiest to balance the ICON A5 with the aircraft upright. Make adjustments as needed to obtain the correct balance (as shown) before flying.

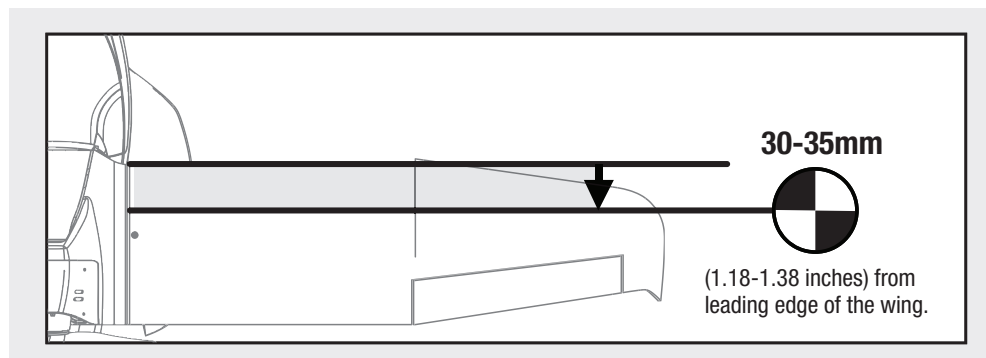

Control Direction Test

Bind your aircraft and transmitter before doing these tests. Move the controls on the transmitter to make sure the aircraft control surfaces move correctly. After doing the Control Test, correctly set the failsafe. Make sure the transmitter controls are at neutral and the throttle and throttle trim are in the low position, then re-bind the model to your transmitter. If the receiver loses its link to the transmitter, the failsafe ensures the controls and throttle revert to the settings made at binding.

Elevator

Up
Elevator

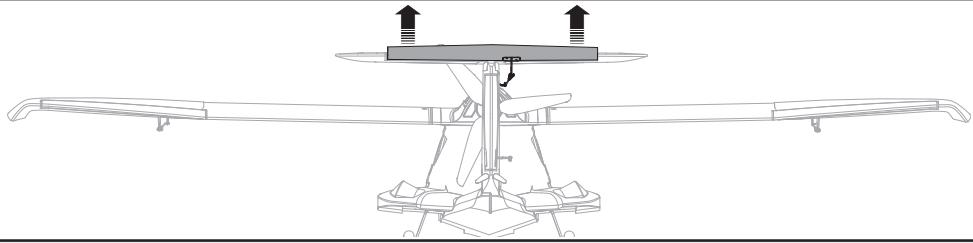

Down
Elevator

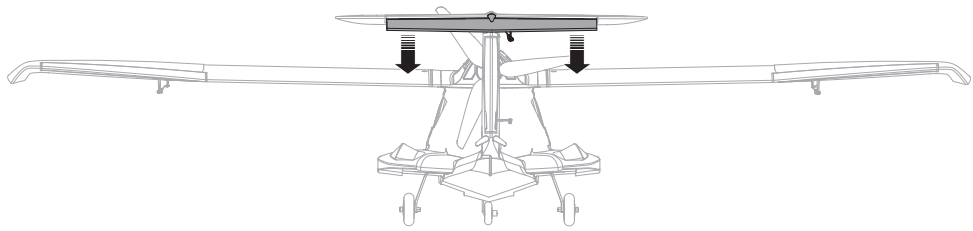

Aileron

Stick
Left

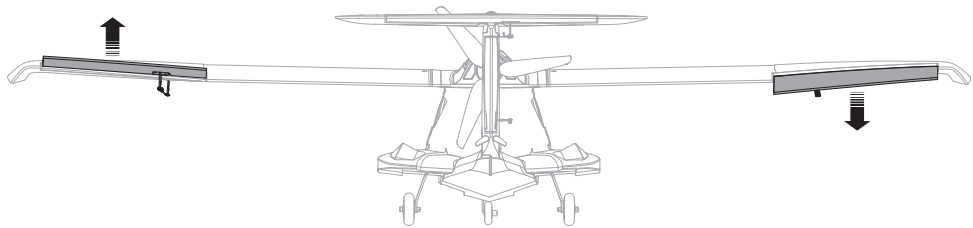

Stick
Right

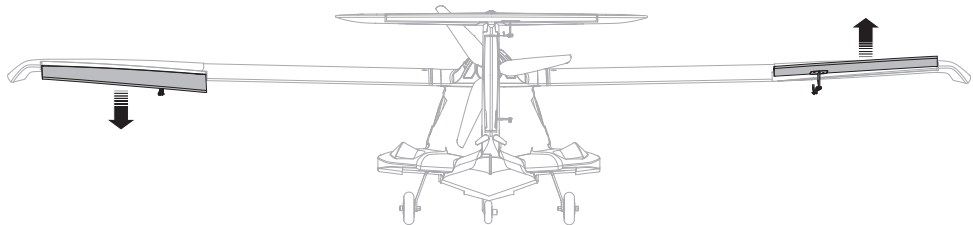

Rudder

Stick
Left

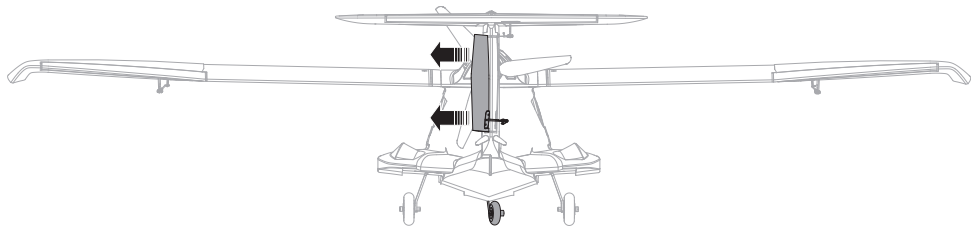

Stick
Right

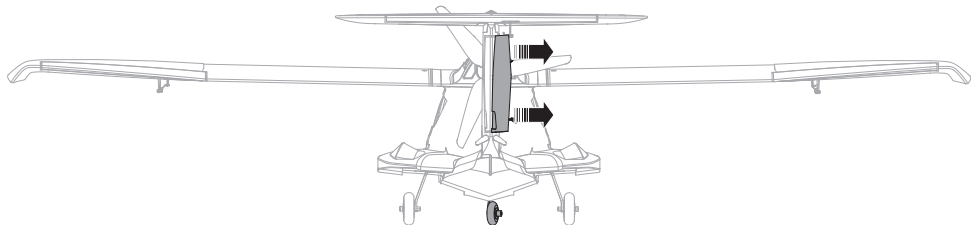

Dual Rates

We recommend using a DSM2/DSMX aircraft transmitter capable of dual rates. Adjust according to individual preferences after initial flight.

It is recommended to land and takeoff in high rate.

	High Rate	Low Rate
Aileron	12mm up/down	8mm up/down
Elevator	11mm up/down	8mm up/down
Rudder	27mm left/right	20mm left/right

Service of Power Components

Disassembly

1. Remove the screw (A) and spinner (B) from the collet shaft (G).
 2. Use a tool to remove the spinner nut (C) from the collet shaft.
 3. Remove the propeller (D), spinner backplate (E), collet backplate (F) and collet (G) from the motor shaft.
 4. Remove four screws (H) from the cowling (I).
 5. Carefully remove the cowling from fuselage. Paint may keep the cowling attached to the fuselage.
 6. Remove four screws (J) from the motor mount (K) and fuselage.
 7. Disconnect the motor wires from the ESC wires.
 8. Remove four screws (L) and the motor (M) from the motor mount.
- Keep rubber washers attached to the motor mount when removing the screws and the motor from the motor mount.

Assembly

Assemble in reverse order.

NOTICE: Make sure the propeller side with the numbers (for example, 9 x 8) faces toward the tail of the airplane. A tool is required to tighten the spinner nut on the collet shaft. Correctly align the wire colors and connect the motor to the ESC.

CAUTION: Always disconnect the flight battery from the model before removing the propeller.

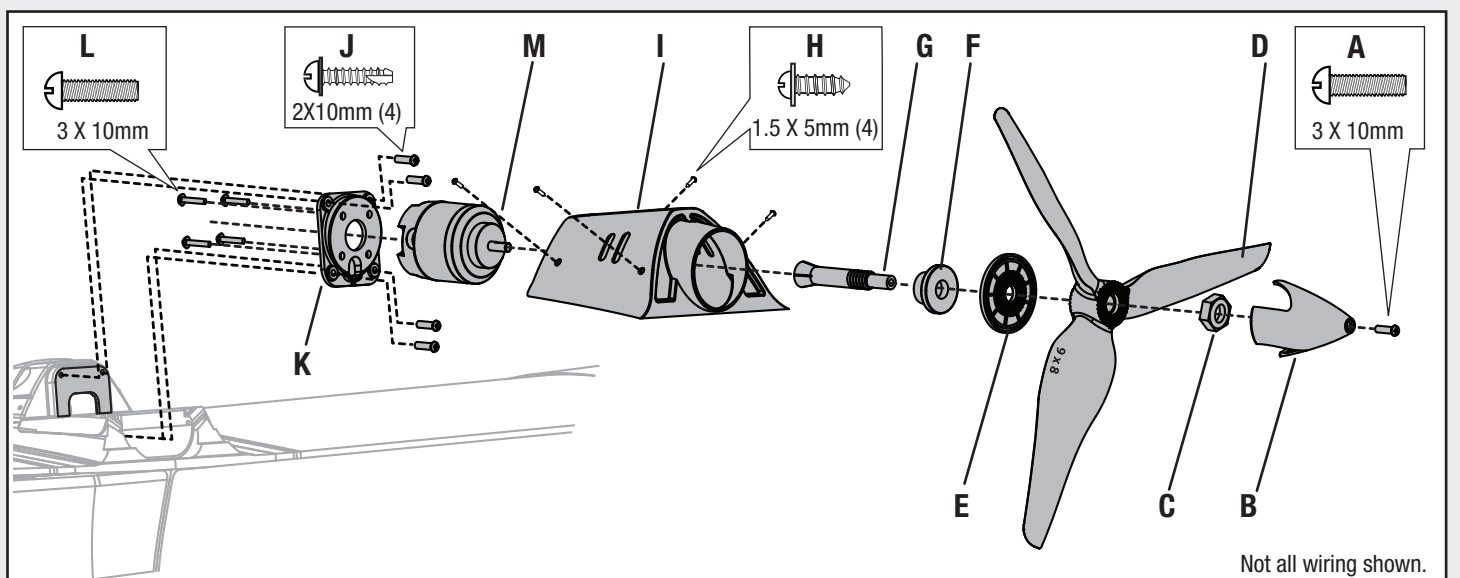

Optional Headlights

1. Inside the fuselage, connect the headlight controller (EFLA600) connector to an unused receiver channel.
2. Put the headlights behind the left and right headlight lenses (A) of the fuselage.
3. Apply a small amount of glue to hold the lights in the fuselage holes (B).

We recommend the blue (EFLA603) or the white lights (EFLA602) in the ICON A5.

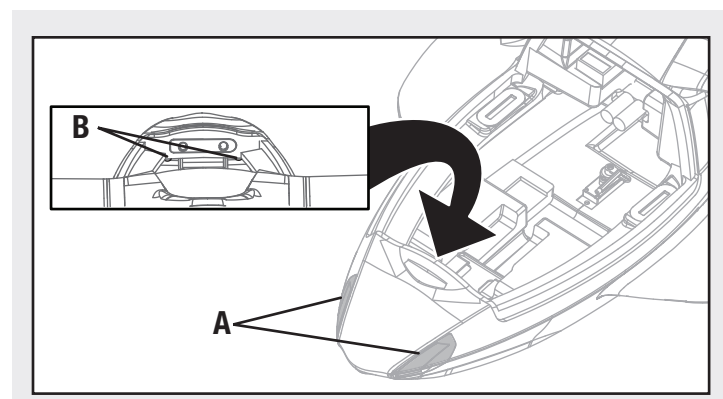

Flying Tips and Repairs

Range Check your Radio System

After final assembly, range check the radio system with the ICON A5. Refer to your specific transmitter instruction manual for range test information.

Flying

Always choose a wide-open space for flying your ParkZone ICON A5. It is ideal that you fly at a sanctioned flying field. If you are not flying at an approved site, always avoid flying near houses, trees, wires and buildings. You should also be careful to avoid flying in areas where there are many people, such as busy parks, schoolyards or soccer fields. Consult local laws and ordinances before choosing a location to fly your aircraft.

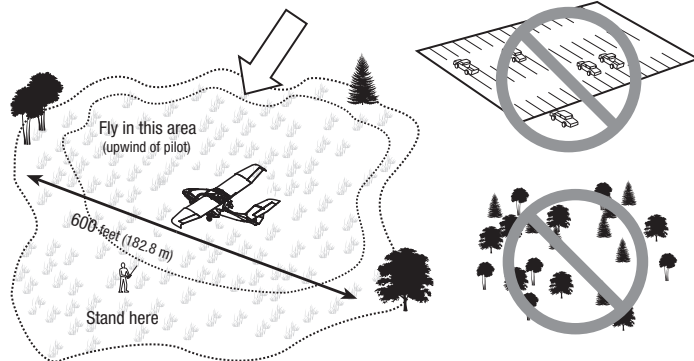

Takeoff

Add power slowly, and steer with the rudder stick. Hold a small amount (1/4–1/3) of up elevator stick and when the airplane is ready to fly it will lift off the ground. Avoid forcing the airplane into the air.

Landing

For your first flights, set your transmitter timer or a stopwatch to 7 minutes. Adjust your timer for longer or shorter flights once you have flown the model. When the motor pulses, land the aircraft immediately and recharge the flight battery. It is not recommended to fly the battery to LVC.

To land the ICON A5, fly the airplane to a couple of feet off the ground at about 1/4 throttle. Reduce power to idle and increase the up elevator to flare the model. Try to avoid touching the nose wheel first as this will cause a bounce. Once the airplane touches down, reduce back pressure on the elevator stick to prevent the plane from becoming airborne again.

Note: It is recommended to land and takeoff on high rates.

Takeoff and Landing on Water

To take off on water, steer with the rudder and slowly increase throttle. Keep the wings level on the takeoff. Hold a small amount (1/4–1/3) of up elevator and the airplane will lift off once flying speed is reached. Avoid rapidly increasing the throttle as the torque from the motor may cause the ICON A5 to roll to the left when on water.

To land the ICON A5 on water, fly the airplane to a couple of feet off the surface of the water. Reduce throttle and add up elevator to flare the model.

When taxiing, you must use some throttle to give propeller blast over the rudder to steer, as there is no water rudder.

Avoid taxiing cross wind if there is a breeze, as this can cause the ICON A5 to flip over if the wind gets under the upwind wing. Taxi at 45 degrees into the direction of the wind (not directly into the wind) and use aileron to hold the upwind wing down.

The ICON A5 will try to face into the wind when taxiing. The wind will naturally turn the airplane to face into the wind.



CAUTION: Never go alone to get a downed model in the water.

NOTICE: Always keep the inside of the fuselage dry to prevent damage to electronic parts.

NOTICE: When finished flying, never keep the airplane in the sun. Do not store the aircraft in a hot, enclosed area such as a car. Doing so can damage the foam.

Repairs

Thanks to the Z-Foam™ construction of the ICON A5, repairs to the foam can be made using virtually any adhesive (hot glue, regular CA (cyanocrylate adhesive), epoxy, etc). When parts are not repairable, see the Replacement Parts List for ordering by item number.

NOTICE: Use of CA accelerant on your model can damage paint. DO NOT handle model until accelerant fully dries.

First Flight Preparation

1. Remove and inspect contents.
2. Charge flight battery.
3. Read this instruction manual thoroughly.
4. Fully assemble model.
5. Install the flight battery in the aircraft (once it has been fully charged).
6. Bind aircraft to your transmitter.
7. Make sure linkages move freely.
8. Perform the Control Direction Test with the transmitter.
9. Adjust flight controls and transmitter.
10. Perform a radio system Range Check.
11. Find a safe and open area.
12. Plan flight for flying field conditions.

Maintenance After Flying

1. Disconnect flight battery from ESC (Required for safety and battery life).
2. Power off transmitter.
3. Remove flight battery from aircraft.
4. Recharge flight battery.
5. Repair or replace all damaged parts.
6. Store flight battery apart from aircraft and monitor the battery charge.
7. Make note of flight conditions and flight plan results, planning for future flights.
8. If flying off water, remove the canopy after flying and make sure inside the fuselage is dry.

AMA National Model Aircraft Safety Code

Effective January 1, 2011

A. GENERAL

A model aircraft is a non-human-carrying aircraft capable of sustained flight in the atmosphere. It may not exceed limitations of this code and is intended exclusively for sport, recreation and/or competition. All model flights must be conducted in accordance with this safety code and any additional rules specific to the flying site.

1. Model aircraft will not be flown:
 - (a) In a careless or reckless manner.
 - (b) At a location where model aircraft activities are prohibited.
2. Model aircraft pilots will:
 - (a) Yield the right of way to all man carrying aircraft.
 - (b) See and avoid all aircraft and a spotter must be used when appropriate. (AMA Document #540-D-See and Avoid Guidance.)
 - (c) Not fly higher than approximately 400 feet above ground level within three (3) miles of an airport, without notifying the airport operator.
 - (d) Not interfere with operations and traffic patterns at any airport, heliport or seaplane base except where there is a mixed use agreement.
 - (e) Not exceed a takeoff weight, including fuel, of 55 pounds unless in compliance with the AMA Large Model Aircraft program. (AMA Document 520-A)
 - (f) Ensure the aircraft is identified with the name and address or AMA number of the owner on the inside or affixed to the outside of the model aircraft. (This does not apply to model aircraft flown indoors).
 - (g) Not operate aircraft with metal-blade propellers or with gaseous boosts except for helicopters operated under the provisions of AMA Document #555.
 - (h) Not operate model aircraft while under the influence of alcohol or while using any drug which could adversely affect the pilot's ability to safely control the model.
 - (i) Not operate model aircraft carrying pyrotechnic devices which explode or burn, or any device which propels a projectile or drops any object that creates a hazard to persons or property.

Exceptions:

 - Free Flight fuses or devices that burn producing smoke and are securely attached to the model aircraft during flight.
 - Rocket motors (using solid propellant) up to a G-series size may be used provided they remain attached to the model during flight. Model rockets may be flown in accordance with the National Model Rocketry Safety Code but may not be launched from model aircraft.
 - Officially designated AMA Air Show Teams (AST) are authorized to use devices and practices as defined within the Team AMA Program Document (AMA Document #718).
 - (j) Not operate a turbine-powered aircraft, unless in compliance with the AMA turbine regulations. (AMA Document #510-A).
3. Model aircraft will not be flown in AMA sanctioned events, air shows or model demonstrations unless:
 - (a) The aircraft, control system and pilot skills have successfully demonstrated all maneuvers intended or anticipated prior to the specific event.
 - (b) An inexperienced pilot is assisted by an experienced pilot.
4. When and where required by rule, helmets must be properly worn and fastened. They must be OSHA, DOT, ANSI, SNELL or NOCSAE approved or comply with comparable standards.

B. RADIO CONTROL

1. All pilots shall avoid flying directly over unprotected people, vessels, vehicles or structures and shall avoid endangerment of life and property of others.
2. A successful radio equipment ground-range check in accordance with manufacturer's recommendations will be completed before the first flight of a new or repaired model aircraft.
3. At all flying sites a safety line(s) must be established in front of which all flying takes place (AMA Document #706-Recommended Field Layout):
 - (a) Only personnel associated with flying the model aircraft are allowed at or in front of the safety line.
 - (b) At air shows or demonstrations, a straight safety line must be established.
 - (c) An area away from the safety line must be maintained for spectators.
 - (d) Intentional flying behind the safety line is prohibited.
4. RC model aircraft must use the radio-control frequencies currently allowed by the Federal Communications Commission (FCC). Only individuals properly licensed by the FCC are authorized to operate equipment on Amateur Band frequencies.
5. RC model aircraft will not operate within three (3) miles of any pre-existing flying site without a frequency-management agreement (AMA Documents #922-Testing for RF Interference; #923- Frequency Management Agreement)
6. With the exception of events flown under official AMA Competition Regulations, excluding takeoff and landing, no powered model may be flown outdoors closer than 25 feet to any individual, except for the pilot and the pilot's helper(s) located at the flight line.
7. Under no circumstances may a pilot or other person touch a model aircraft in flight while it is still under power, except to divert it from striking an individual. This does not apply to model aircraft flown indoors.
8. RC night flying requires a lighting system providing the pilot with a clear view of the model's attitude and orientation at all times.
9. The pilot of a RC model aircraft shall:
 - (a) Maintain control during the entire flight, maintaining visual contact without enhancement other than by corrective lenses prescribed for the pilot.
 - (b) Fly using the assistance of a camera or First-Person View (FPV) only in accordance with the procedures outlined in AMA Document #550.

Please see your local or regional modeling association's guidelines for proper, safe operation of your model aircraft.

Troubleshooting Guide

Problem	Possible Cause	Solution
Aircraft will not respond to throttle but responds to other controls	Throttle is not at idle and/or throttle trim is too high	Reset controls with throttle stick and throttle trim at lowest setting
	Throttle servo travel is lower than 100%	Make sure throttle servo travel is 100% or greater
	Throttle channel is reversed	Reverse throttle channel on transmitter
Extra propeller noise or extra vibration	Damaged propeller and spinner, collet or motor	Replace damaged parts
	Propeller is out of balance	Balance or replace propeller
Reduced flight time or aircraft underpowered	Flight battery charge is low	Completely recharge flight battery
	Propeller is installed backwards	Make sure the propeller side with the numbers (for example, 9 x 8) faces toward the tail of the airplane.
	Flight battery is damaged	Replace flight battery and follow flight battery instructions
	Flight conditions may be too cold	Make sure battery is warm before use
Aircraft will not Bind (during binding) to transmitter	Transmitter is too near aircraft during binding process	Move powered transmitter a few feet from aircraft, disconnect and reconnect flight battery to aircraft
	Aircraft or transmitter is too close to large metal object	Move aircraft and transmitter away from large metal object
	Bind plug is not installed correctly in bind port	Install bind plug in bind port and bind aircraft to transmitter
	Flight battery/Transmitter battery charge is too low	Replace/recharge batteries
Aircraft will not link (after binding) to transmitter	Transmitter is too near aircraft during linking process	Move powered transmitter a few feet from aircraft, disconnect and reconnect flight battery to aircraft
	Aircraft or transmitter is too close to large metal object	Move aircraft and transmitter away from large metal object
	Bind plug is left installed in bind port	Remove bind plug before cycling power
	Aircraft bound to different model memory (ModelMatch™ radios only)	Select correct model memory on transmitter
	Flight battery/Transmitter battery charge is too low	Replace/recharge batteries
	Transmitter may have been bound to a different model (using different DSM Protocol)	Bind aircraft to transmitter
Control surface does not move	Control surface, control horn, linkage or servo damage	Replace or repair damaged parts and adjust controls
	Wire is damaged or connections are loose	Do a check of wires and connections, connect or replace as needed
	Transmitter is not bound correctly or the incorrect model was selected	Re-bind or select correct model in transmitter
	BEC (Battery Elimination Circuit) of the ESC is damaged	Replace ESC
Controls reversed	Transmitter settings are reversed	Do the Control Direction Test and adjust controls on transmitter appropriately
Motor power pulses then motor loses power	ESC uses default soft Low Voltage Cutoff (LVC)	Recharge flight battery or replace battery that is no longer performing
	Weather conditions might be too cold	Postpone flight until weather is warmer
	Battery is old, worn out, or damaged	Replace battery
	Battery C rating might be too small	Use recommended 25C battery

Limited Warranty

What this Warranty Covers

Horizon Hobby, Inc. ("Horizon") warrants to the original purchaser that the product purchased (the "Product") will be free from defects in materials and workmanship at the date of purchase.

What is Not Covered

This warranty is not transferable and does not cover (i) cosmetic damage, (ii) damage due to acts of God, accident, misuse, abuse, negligence, commercial use, or due to improper use, installation, operation or maintenance, (iii) modification of or to any part of the Product, (iv) attempted service by anyone other than a Horizon Hobby authorized service center, or (v) Products not purchased from an authorized Horizon dealer.

OTHER THAN THE EXPRESS WARRANTY ABOVE, HORIZON MAKES NO OTHER WARRANTY OR REPRESENTATION, AND HEREBY DISCLAIMS ANY AND ALL IMPLIED WARRANTIES, INCLUDING, WITHOUT LIMITATION, THE IMPLIED WARRANTIES OF NON-INFRINGEMENT, MERCHANTABILITY AND FITNESS FOR A PARTICULAR PURPOSE. THE PURCHASER ACKNOWLEDGES THAT THEY ALONE HAVE DETERMINED THAT THE PRODUCT WILL SUITABLY MEET THE REQUIREMENTS OF THE PURCHASER'S INTENDED USE.

Purchaser's Remedy

Horizon's sole obligation and purchaser's sole and exclusive remedy shall be that Horizon will, at its option, either (i) service, or (ii) replace, any Product determined by Horizon to be defective. Horizon reserves the right to inspect any and all Product(s) involved in a warranty claim. Service or replacement decisions are at the sole discretion of Horizon. Proof of purchase is required for all warranty claims. SERVICE OR REPLACEMENT AS PROVIDED UNDER THIS WARRANTY IS THE PURCHASER'S SOLE AND EXCLUSIVE REMEDY.

Limitation of Liability

HORIZON SHALL NOT BE LIABLE FOR SPECIAL, INDIRECT, INCIDENTAL OR CONSEQUENTIAL DAMAGES, LOSS OF PROFITS OR PRODUCTION OR COMMERCIAL LOSS IN ANY WAY, REGARDLESS OF WHETHER SUCH CLAIM IS BASED IN CONTRACT, WARRANTY, TORT, NEGLIGENCE, STRICT LIABILITY OR ANY OTHER THEORY OF LIABILITY, EVEN IF HORIZON HAS BEEN ADVISED OF THE POSSIBILITY OF SUCH DAMAGES. Further, in no event shall the liability of Horizon exceed the individual price of the Product on which liability is asserted. As Horizon has no control over use, setup, final assembly, modification or misuse, no liability shall be assumed nor accepted for any resulting damage or injury. By the act of use, setup or assembly, the user accepts all resulting liability. If you as the purchaser or user are not prepared to accept the liability associated with the use of the Product, purchaser is advised to return the Product immediately in new and unused condition to the place of purchase.

Law

These terms are governed by Illinois law (without regard to conflict of law principals). This warranty gives you specific legal rights, and you may also have other rights which vary from state to state. Horizon reserves the right to change or modify this warranty at any time without notice.

Warranty Services

Questions, Assistance, and Services

Your local hobby store and/or place of purchase cannot provide warranty support or service. Once assembly, setup or use of the Product has been started, must contact your local distributor or Horizon directly. This will enable Horizon to better answer your questions and service you in the event that you may need any assistance. For questions or assistance, please direct your email to productsupport@horizonhobby.com, or call 877.504.0233 toll free to speak to a Product Support representative. You may also find information on our website at www.horizonhobby.com

Inspection or Services

If this Product needs to be inspected or serviced, please use the Horizon Online Service Request submission process found on our website or call Horizon to obtain a Return Merchandise Authorization (RMA) number. Pack the Product securely using a shipping carton. Please note that original boxes may be included, but are not designed to withstand the rigors of shipping without additional protection. Ship via a carrier that provides tracking and insurance for lost or damaged parcels, as Horizon is not responsible for merchandise until it arrives and is accepted at our facility. An Online Service Request is available at www.horizonhobby.com under the Support tab. If you do not have internet access, please contact Horizon Product Support to obtain a RMA number along with instructions for submitting your product for service. When calling Horizon, you will be asked to provide your complete name, street address, email address and phone number where you can be reached during business hours. When sending product into Horizon, please include your RMA number, a list of the included items, and a brief summary of the problem. A copy of your original sales receipt must be included for warranty consideration. Be sure your name, address, and RMA number are clearly written on the outside of the shipping carton.

Notice: Do not ship LiPo batteries to Horizon. If you have any issue with a LiPo battery, please contact the appropriate Horizon Product Support office.

Warranty Requirements

For Warranty consideration, you must include your original sales receipt verifying the proof-of-purchase date. Provided warranty conditions have been met, your Product will be serviced or replaced free of charge. Service or replacement decisions are at the sole discretion of Horizon.

Non-Warranty Service

Should your service not be covered by warranty service will be completed and payment will be required without notification or estimate of the expense unless the expense exceeds 50% of the retail purchase cost. By submitting the item for service you are agreeing to payment of the service without notification. Service estimates are available upon request. You must include this request with your item submitted for service. Non-warranty service estimates will be billed a minimum of ½ hour of labor. In addition you will be billed for return freight. Horizon accepts money orders and cashiers checks, as well as Visa, MasterCard, American Express, and Discover cards. By submitting any item to Horizon for service, you are agreeing to Horizon's Terms and Conditions found on our website www.horizonhobby.com/Service/Request/.

Contact Information

Country of Purchase	Horizon Hobby	Address	Phone Number/Email Address
United States of America	Horizon Service Center (Electronics and engines)	4105 Fieldstone Rd Champaign, Illinois 61822 USA	877-504-0233 Online Repair Request: visit www.horizonhobby.com/service
	Horizon Product Support (All other products)	4105 Fieldstone Rd Champaign, Illinois 61822 USA	877-504-0233 productsupport@horizonhobby.com
United Kingdom	Horizon Hobby Limited	Units 1-4 Ployters Rd Staple Tye Harlow, Essex CM18 7NS United Kingdom	+44 (0) 1279 641 097 sales@horizonhobby.co.uk
Germany	Horizon Technischer Service	Hamburger Str. 10 25335 Elmshorn Germany	+49 4121 46199 66 service@horizonhobby.de
France	Horizon Hobby SAS	14 Rue Gustave Eiffel Zone d'Activité du Réveil Matin 91230 Montgeron	+33 (0) 1 60 47 44 70 infofrance@horizonhobby.com

Compliance Information for the European Union

Declaration of Conformity

(in accordance with ISO/IEC 17050-1)

No. HH2011073001

Product(s): ICON A5 BNF
Item Number(s): PKZ5880
Equipment class: 1

The object of declaration described above is in conformity with the requirements of the specifications listed below, following the provisions of the European R&TTE directive 1999/5/EC and EMC Directive 2004/108/EC:

EN 301 489-1 V1.7.1: 2006
EN 301 489-17 V1.3.2: 2008

EN55022: 2006,
EN55024: 1998+A1: 2001+A2: 2003



Signed for and on behalf of:
Horizon Hobby, Inc.
Champaign, IL USA
July 30, 2011

Steven A. Hall
Vice President
International Operations and
Risk Management
Horizon Hobby, Inc.

Declaration of Conformity

(in accordance with ISO/IEC 17050-1)

No. HH2011073002

Product(s): ICON A5 PNP
Item Number(s): PKZ5875
Equipment class: 1

The object of declaration described above is in conformity with the requirements of the specifications listed below, following the provisions of the European R&TTE directive 1999/5/EC:

EN 301 489-1 V1.7.1: 2006
EN 301 489-3 V1.4.1: 2008



Signed for and on behalf of:
Horizon Hobby, Inc.
Champaign, IL USA
July 30, 2011

Steven A. Hall
Vice President
International Operations and
Risk Management
Horizon Hobby, Inc.

Instructions for disposal of WEEE by users in the European Union



This product must not be disposed of with other waste. Instead, it is the user's responsibility to dispose of their waste equipment by handing it over to a designated collections point for the recycling of waste electrical and electronic equipment. The separate collection and recycling of your waste equipment at the time of disposal will help to conserve natural resources and ensure that it is recycled in a manner that protects human health and the environment. For more information about where you can drop off your waste equipment for recycling, please contact your local city office, your household waste disposal service or where you purchased the product.

Parts Contact Information • Kontaktinformationen für Ersatzteile
• Coordonnés pour obtenir de pièces détachées • Recapiti per i ricambi

Country of Purchase	Horizon Hobby	Address	Phone Number/Email Address
United States of America	Sales	4105 Fieldstone Rd Champaign, Illinois 61822 USA	800-338-4639 Sales@horizonhobby.com
United Kingdom	Horizon Hobby Limited	Units 1-4 Ployters Rd Staple Tye Harlow, Essex CM18 7NS United Kingdom	+44 (0) 1279 641 097 sales@horizonhobby.co.uk
Germany	Horizon Technischer Service	Hamburger Str. 10 25335 Elmshorn Germany	+49 4121 46199 60 service@horizonhobby.de
France	Horizon Hobby SAS	14 Rue Gustave Eiffel Zone d'Activité du Réveil Matin 91230 Montgeron	+33 (0) 1 60 47 44 70 infofrance@horizonhobby.com

Replacement Parts • Ersatzteile • Pièces de rechange • Pezzi di ricambio

Part # Nummer Numéro Codice	Description	Beschreibung	Description	Descrizione
PKZ5801	Prop with Spinner: ICON A5	Propeller mit Spinner: ICON A5	Cône avec hélice: ICON A5	Elica con ogiva: ICON A5
PKZ5802	Decal Sheet: ICON A5	Dekorbogen: ICON A5	Planche de décoration: ICON A5	Foglio adesivi: ICON A5
PKZ5803	Landing Gear Set: ICON A5	Fahrwerkset: ICON A5	Set de train d'atterrissage: ICON A5	Set carrelli: ICON A5
PKZ5804	Prop Adapter: ICON A5	Propeller Adapter: ICON A5	Adaptateur d'hélice: ICON A5	Adattatore elica: ICON A5
PKZ5807	Pushrod/Clevis Set: ICON A5	Schubstange/ Gabelkopf Set : ICON A5	Set de tringleries: ICON A5	Set comandi con forcelle: ICON A5
PKZ5812	Horizontal Tail w/Access: ICON A5	Höhenleitwerk m. Zbh : ICON A5	Stabilisateur avec visserie: ICON A5	Piano di coda orizz. c/access.: ICON A5
PKZ5813	Scale Cockpit: ICON A5	Scale Cockpit: ICON A5	Cockpit: ICON A5	Cruscotto in scala: ICON A5
PKZ5814	Civilian Pilot: ICON A5	Zivilpilot: ICON A5	Pilote civil: ICON A5	Pilota civile: ICON A5
PKZ5820	Wing Set: ICON A5	Tragflächenset: ICON A5	Aile: ICON A5	Set ali: ICON A5
PKZ5821	Wing Tube: ICON A5	Flächenverbinder: ICON A5	Clé d'aile: ICON A5	Tubo ala: ICON A5
PKZ5828	Motor Mount and Cover: ICON A5	Motorträger und Abdeckung: ICON A5	Support moteur et capot: ICON A5	Supporto motore e caren: ICON A5
PKZ5867	Painted Bare Fuselage: ICON A5	Rumpf lackiert: ICON A5	Fuselage nu: ICON A5	Solo fusoliera verniciata: ICON A5
EFLA1030	30-AMP Pro SB Brushless ESC	30A Pro SB Regler	Contrôleur brushless 30A Pro SB	30-AMP Pro SB Brushless ESC
PKZ4416	480 BL Outrunner Motor, 960Kv	480Bl Außenläufer 960kv	Moteur brushless à cage tournante classe 480, 960Kv	480 BL motore cassa rotante: 960Kv
PKZ1081	SV80 Long Lead 3-Wire Servo:T28 (Ailerons)	SV80 Servo mit langem Kabel	Servo SV80 câblage long:T28 (Ailerons)	SV80 servo con filo lungo:T28 (Alettoni)
PKZ1090	DSV130 Digital Servo w/Metal Gears	DSV130 Digitalservo MG	Servo digital DSV130 /pignons métal	DSV130 Servo digitale c/ingran. metallo
SPMAR600	AR600 6-CH Sport DSMX Receiver	Spektrum AR600 DSMX 6 Kanal Sport Empfänger	Récepteur AR600 6 voies	AR600 6-CH Sport DSMX Ricevitore
PKZ1029	11.1V 3S 25C 2200mAh Li-Po	11.1V 3S 25C 2200mAh LiPo	11.1V 3S 25C 2200mAh Li-Po	11.1V 3S 25C 2200mAh Li-Po
PKZ1040	2-3 DC Li-Po Balancing Charger	ParkZone 12V 2-3S LiPo Balancer Lader	Chargeur équilibre Li-po 2-3S	2-3 DC Li-Po Caricabatterie c/ bilanciatore

Optional Parts • Optionale Bauteile • Pièces optionnelles • Pezzi opzionali

Part # Nummer Numéro Codice	Description	Beschreibung	Description	Descrizione
EFLA250	Park Flyer Tool Assortment, 5 pc	Park Flyer Werkzeugsortiment, 5 teilig	Assortiment d'outils park flyer, 5pc	Park Flyer assortimento attrezzi, 5 pc
EFLAEC302	EC3 Battery Connector, Female (2)	EC3 Akkukabel, Buchse (2)	Prise EC3 femelle (2pc)	EC3 Connettore femmina x batteria (2)
EFLAEC303	EC3 Device/Battery Connector, Male/Female	EC3 Kabelsatz, Stecker/Buchse	Prise EC3 male/femelle	EC3 Connettore batteria maschio/femmina
EFLC505	1- To 5-cell Li-Po battery charger with balancer	E-flite 1-5 Zellen Li-Po Lader mit Balancer	Chargeur équilibrer Li-Po 1-5S	Da 1 a 5-celle Li-Po caricabatterie c/ bilanciatore
EFLC3025	80W AC/DC multi-chemistry battery charger	80W AC/DC Multi-Batterie Ladegerät - EU	Chargeur multiple AC/DC 80W	80W AC/DC Caricabatterie universale
SPMAR600	AR600 6-Channel Sport DSM2/ DSMX Receiver	Spektrum AR600 DSMX 6 Kanal Sport Empfänger	Récepteur AR600 6 voies DSM2/DSMX	AR600 6-canali Sport DSM2/DSMX ricevitore
SPMR5510	DX5e DSMX 5-Channel Transmitter Only Mode 2	Spektrum DX5e DSMX 5 Kanalsender ohne Empfänger MD 2	DX5e émetteur seul, mode 2	DX5e DSMX 5-canali solo trasmettitore Mode 2
SPMR55101	DX5e DSMX 5-Channel Transmitter Only Mode 1	Spektrum DX5e DSMX 5 Kanalsender ohne Empfänger MD 1	DX5e émetteur seul, mode 1	DX5e DSMX 5-canali solo trasmettitore Mode 1
SPMR6610	DX6i DSMX Transmitter Only Mode 2	Spektrum DX6i DSM X Sender ohne Empfänger MD2	DX6i émetteur seul, mode 2	DX6i DSMX solo trasmettitore Mode 2
SPMR66101	DX6i DSMX Transmitter Only Mode 1	Spektrum DX6i DSM X Sender ohne Empfänger MD1	DX6i émetteur seul, mode 1	DX6i DSMX solo trasmettitore Mode 1
SPMR6610E	DX6i DSMX Transmitter Only Mode 2 Int'l	Spektrum DX6i DSM X Sender ohne Empfänger MD2	DX6i émetteur seul, mode 2 Int'l	DX6i DSMX solo trasmettitore Mode 2 Int'l
SPMR66101E	DX6i DSMX Transmitter Only Mode 1 Int'l	Spektrum DX6i DSM X Sender ohne Empfänger MD1	DX6i émetteur seul, mode 1 Int'l	DX6i DSMX solo trasmettitore Mode 1 Int'l
*SPMR8800	DX8 DSMX Transmitter Only Mode 2	DX8 DSMX Transmitter Only Mode 2	DX8 émetteur seul, mode 2	DX8 DSMX solo trasmettitore Mode 2
*SPMR8800EU	DX8 DSMX Transmitter Only Mode 2 Int'l	Spektrum DX8 nur Sender Mode 1-4	DX8 émetteur seul, mode 2 Int'l	DX8 DSMX solo trasmettitore Mode 2 Int'l
*SPMR88001EU	DX8 DSMX Transmitter Only Mode 1 Int'l	DX8 Transmitter Only MD1	DX8 émetteur seul, mode 1 Int'l	DX8 DSMX solo trasmettitore Mode 1 Int'l
*SPMR88001AU	DX8 DSMX Transmitter Only Mode 1 AU	DX8 DSMX Transmitter Only Mode 1 AU	DX8 émetteur seul, mode 1 AU	DX8 DSMX solo trasmettitore Mode 1 AU

* All Spektrum DX8 transmitters can be set up for modes 1–4

* Alle Spektrum DX8 Sender können für Mode 1 - 4 eingestellt werden

* Tous les émetteurs Spektrum DX8 peuvent être paramétrés dans les 4 modes

* Tutti i trasmettitori Spektrum DX8 possono essere configurati per i modelli 1 - 4

© 2011 Horizon Hobby, Inc.

ParkZone, DSM, DSMX, DSM2, ModelMatch, Bind-N-Fly, Z-Foam and Plug-N-Play are trademarks or registered trademarks of Horizon Hobby, Inc.

The Spektrum trademark is used with permission of Bachmann Industries, Inc.

Futaba is a registered trademark of Futaba Denshi Kogyo Kabushiki Kaisha Corporation of Japan.

Patents Pending

www.parkzone.com

PKZ5880, PKZ5875

Created 08/11 32738

