



Miss LLumar

1/12-Scale RTR Nitro Unlimited Hydroplane

Owner's Manual



Specifications

Overall Length	27.5 in (698.5mm)
Beam	14 in (355.6mm)
Engine	DYN .15 Marine w/Recoil
Radio System	JR AM 75MHz Python

Table of Contents

Introduction	2
Warning	2
Additional Required Items	3
Suggested Field Equipment and Supplies	3
Contents	3
Section 1: Installation of Receiver and Transmitter Batteries	4-5
Section 2: Turn Fin	6
Section 3: Filling the Fuel Tank	6
Section 4: Range Checking the JR Python Radio System.....	6
Section 5: The Dynamite .15 Marine Engine.....	6-7
Troubleshooting Guide	7-8
Section 6: Maintenance	8-9
Section 7: Miss LLumar Replacement Parts	10
Appendix	10
Notes	12

Introduction

Congratulations on the purchase of your Pro Boat™ 1/12 Miss LLumar Unlimited Hydroplane. You are just minutes from one of the most thrilling experiences that the radio control hobby has to offer.

The Pro Boat Miss LLumar is a professionally built, ready-to-run 1/12-scale fiberglass model of one of the most competitive teams on the Unlimited Hydroplane tour. Powered by the potent Dynamite® .15S marine engine, you will be able to race across the water at scale speeds in excess of 300mph!

Read this owner's manual thoroughly. You also need to read the included Dynamite .15 engine manual, along with the JR® Python radio system manual.

It is very important that you operate this boat responsibly. With proper care and maintenance, you will be able to enjoy your Miss LLumar for many years to come.

Carefully unpack Miss LLumar and examine the boat and its contents. The contents contain the Miss LLumar RTR with radio installed, a boat stand, and the JR Python radio transmitter. If you are missing any of these items or notice any damage, immediately contact the place of purchase.

WARNING

**This boat is not a toy! It is a high-performance RC model boat.
Do not take risks that could endanger you or others.**

Before operating your model, make sure your frequency is clear. If someone else is operating on the same frequency, both models could go out of control, possibly causing damage to the models, as well as to others.

Be certain to check all of the hardware, exhaust system, and propeller, making sure that all are secure before and after each run. **Always keep clear of the propeller when the engine is running!**

When you first begin to run your Miss LLumar, place in water with engine running at approximately ¼ throttle. Slowly increase throttle until boat accelerates onto plane. Gradually increase throttle to no more than ½ until you become more familiar with the boat. Remember, this boat makes right turns only!

When operating this model, stay clear of people, full-sized boats, stationary objects, and wildlife. Also, watch out for fishing lines that could get tangled in the propeller. It is preferable to operate the Pro Boat™ Miss LLumar in low wake, low wind conditions

and in areas free of people, objects, and wildlife. We also suggest that you do not run the Miss LLumar in salt water.

If at any time while operating your Miss LLumar you sense any abnormal function, end your operation immediately. Do not operate your Miss LLumar again until you are certain the problem has been corrected.

Because this is a scale high-performance model, the Miss LLumar has been set up to turn to the right only! **Do not attempt left turns or you will flip the boat. If you need to turn left, reduce throttle and turn in a very large diameter oval.**

Service Center Information

If you have any questions regarding the Pro Boat Miss LLumar, please contact:

Horizon Service Center
4105 Fieldstone Rd.
Champaign, IL 61822
1-877-504-0233

Additional Required Items

Although the Miss LLumar comes fully assembled and ready for action, you will need a few tools to get your boat ready to run:

Blue Thunder 20% Fuel (quart) (DYN2320)
500cc Fuel Bottle (DYN2003) or
Fast Tap Quart Bottle Spout (DYN2009)
Glow Plug Wrench (DYN2510)
Ni-Cd Glow Driver (DYN1925)
12 "AA" alkaline batteries (8 for the transmitter and 4 for the receiver)
Clear 3M tape to seal radio box

Suggested Field Equipment and Supplies

In addition to the items needed to run the Miss LLumar, we recommend that you carry the following in your field box:

Engine Tuning Screwdriver (DYN2775)
Replacement Glow Plugs (DYN2508 or DYN2500)
Hex driver/Allen wrench (1.5mm and 2.5mm)
Cable grease to lubricate drive shaft
Clean towels and rags
"AA" alkaline batteries
Adjustable wrench (small)
11mm wrench
Extra propellers

Contents

- Assembled Miss LLumar 1/12-Scale RTR
- JR® Python radio transmitter
- Prebuilt boat stand



Section 1: Installation of Receiver and Transmitter Batteries

Receiver Batteries



- Remove the two knurled aluminum nuts that secure the cockpit as shown. Pull the cockpit off the boat.
- Carefully note how the exhaust system is assembled.



- Remove the clear lid that covers the radio box.



- Use a 2.5mm Allen wrench to remove the tuned pipe mount as shown above.



- Remove the dry cell battery holder from the radio box and unwrap the foam around the dry cell battery holder. Install 4 "AA" alkaline batteries into it as shown. Note the proper polarity. Wrap the battery box in foam.

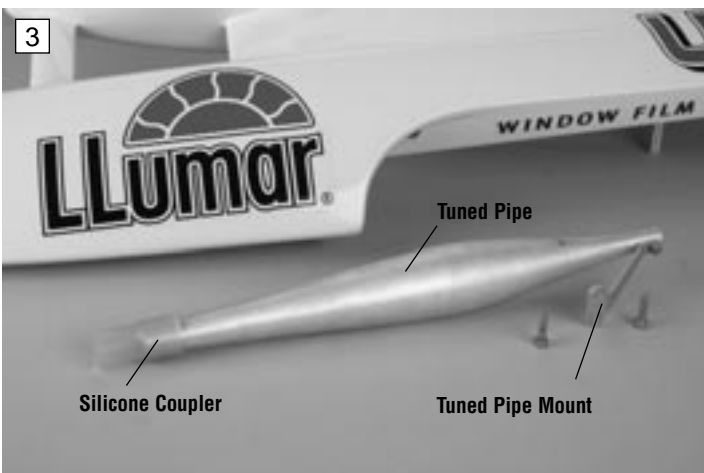

- Carefully remove the tuned pipe by sliding the silicone coupler apart from the exhaust header.

Section 1: Installation of Receiver and Transmitter Batteries (cont.)



6A



8A



8B

- Re-install the tuned pipe mount.



6B

- Re-install the battery holder back into the radio box and properly seal the radio box with clear tape. Failure to properly seal the radio box could result in damage to your radio equipment.

Transmitter Batteries

- Remove the transmitter from the box.



9A



9B



9C

- Remove the battery cover on the bottom of the transmitter.
- Note the proper polarity and insert 8 "AA" batteries into the transmitter.
- Turn on the radio to ensure the batteries have been installed correctly.
- Turn the radio off.

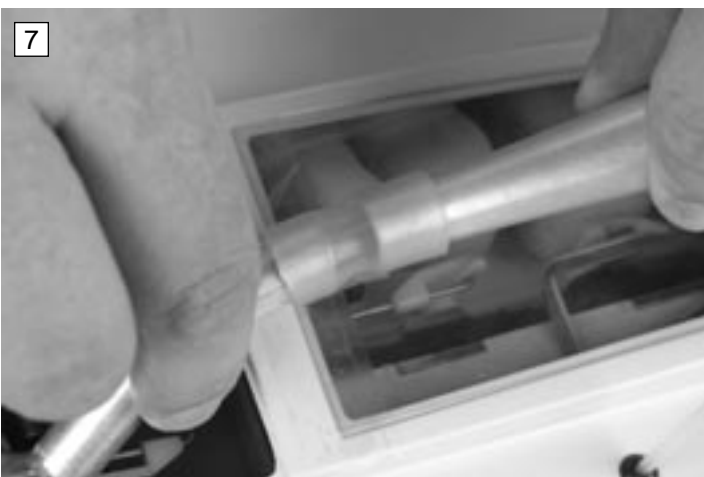

7

- Re-attach the tuned pipe and coupler to the exhaust manifold.

Section 2: Turn Fin

The Miss LLumar comes with the turn fin installed on the right sponson. You will want you run the Miss LLumar in an oval and in an area that will allow you to make right turns (clockwise).

Do not attempt to make tight left hand turns (counterclockwise), or you could easily flip the boat. If you need to make a left turn, do so in a large diameter turn at slow speeds.

Section 3: Filling the Fuel Tank

We recommend that you use Blue Thunder™ 20% fuel. For maximum performance, we recommend Blue Thunder Race Formula. Blue Thunder fuels are specifically formulated for excellent power and engine protection.

Locate the fuel tank inside the cockpit area and unscrew the lid. Use either the DYN2009 Fast Tap™ quart bottle spout that has

been attached to the quart of fuel or the DYN2003 Fuel Bottle to fill the fuel tank with your selection of Blue Thunder fuel. After you have filled the fuel tank and re-installed the lid, wipe away any excess fuel that may have been spilled inside the hull or elsewhere on the boat. Immediately seal the fuel container by putting the lid back on after refueling in order to protect the fuel from moisture.

Section 4: Range Checking the JR Python Radio System

Before the first run of the Miss LLumar, range check the radio for proper operation and to ensure proper control movement of the rudder and throttle. Also ensure that the antenna on the boat is extended properly and that all batteries are in working condition.

1. With the radio system turned on (transmitter and receiver) and the transmitter antenna down (engine off), walk off 40 to 50 paces from the Miss LLumar.
2. Have an assistant remain with the boat to check for proper control movement of the rudder from your transmitter input.
3. If everything appears to be operating correctly, raise the

antenna and start the engine (refer to Section 5 of this manual and to the separate DYN .15 engine manual). Place the boat in the water and run it (at about 1/2 throttle) close to the shoreline. If the radio system is operating properly, you can begin to run the boat faster and further away from the shoreline.

Note: It is a good idea to range check prior to operating your boat after any repair, installation of new batteries, or at the beginning of each boating season.

Section 5: The Dynamite .15 Marine Engine

Water-Cooled Engine

Because the Dynamite® 15S engine is water-cooled and not air-cooled, make sure that you do not run the engine for an extended amount of time outside of the water. Continuously monitor the water outlet when the boat is running to make sure that the water is reaching the engine head. If the water does not reach the head to cool it, the engine will overheat and fail. This could cause permanent damage to the engine.

Pro Mix Carburetor

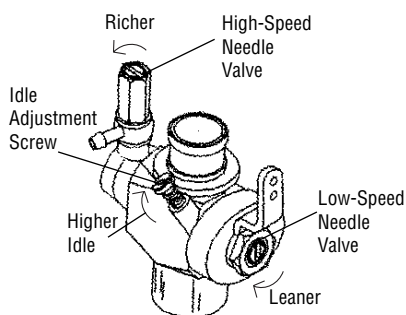

The Dynamite .15 engine comes equipped with the Dynamite Pro Mix Carburetor. Each Pro Mix Carburetor is pre-adjusted at the factory. This setting should be approximately 3 1/2 turns open for the high-speed and 2 1/2 turns open for the low-speed needle. This should give you a slightly "rich" mixture of fuel to the engine. This setting is the safest way to break in your engine. For further details regarding the Pro Mix Carburetor, please consult Section 2 of the Dynamite .15S instruction manual.

Note: When using the pull-starter, never pull the rope out to its full length as doing so can cause damage and the rope may not retract. Quick, short pulls of the starter rope are the best technique to use with the pull-starter.

If the pull-starter becomes very difficult to pull, the engine may be hydro-locked. Excessive fuel between the head and piston will not let the piston travel to TDC (Top Dead Center). Loosen the glow plug one turn and try to start the engine. If the engine starts, re-tighten the glow plug with the attached glow driver while the engine is running. If you are still unable to get your engine to start, refer to the Troubleshooting Guide (page 8) in this manual.

Section 5: The Dynamite .15 Marine Engine (cont.)

You may have to "blip" the throttle on the transmitter (applying throttle on/off) while trying to start the engine. New engines are harder to start because of the tight piston/sleeve fit. **Never start an engine at ½ to full throttle, as this will cause over-revving which may cause premature wear and breakage.**

During the first tank of fuel, advance the idle via the idle adjustment screw more than normal to prevent stalling at idle due to the rich fuel mixture for break-in.

Breaking in Your Engine

The first start-up of the engine is the most critical moment of the engine's life, dictating how the engine will perform from that time forward. Turn on your radio system and attach a fully charged glow igniter (DYN1925) to the glow plug. Start the engine with the recoil (pull-start) on the engine.

During break-in, the low-speed needle should be slightly rich and the high speed needle should be very rich. After a few tanks of fuel, begin to lean the engine out. Adjust the high-speed needle ¼ of a turn at a time. It generally takes about five to six tanks of fuel before you want to lean out the engine until it supplies good power. **Do not skip this process of break-in. Failure to follow this procedure could damage your new engine.** For further details on breaking in your engine, please see Section 3 of the Dynamite® .15S instruction manual.

Note: It is common for an ABC engine to go through a glow plug or two during break-in.

Needle Settings

When adjusting the settings, always adjust the needles in small increments, about ¼ of a full turn at a time. **Do not set the engine too lean, as it shortens the reliability of the engine.** Please refer to Section 4 of the Dynamite .15S instruction manual to learn more about setting the needle valves.

After you have attained the correct needle settings, the engine will have a strong sounding, high-pitched whine at full speed, and a thin trail of blue/white smoke will come from the exhaust.

Idle Adjustment

The last setting is to set the idle screw. To obtain a higher idle, turn the idle screw clockwise; for lower idle, turn the idle screw counterclockwise.

Replacement Parts

There is a complete parts listing in the Dynamite .15S instruction manual in the event that you need to replace an engine part. Exploded views will help you to select the correct parts and make minor repairs.

Troubleshooting Guide

Problem	Possible Solution
Engine will not start	<ul style="list-style-type: none"> Check needles and make changes back to factory settings if necessary Improper needle setting Out of fuel Improper fuel Improper glow plug Glow igniter not charged Dead glow plug Flooded engine
Engine starts, then dies	<ul style="list-style-type: none"> Pressure line blocked or unhooked Reset needles to baseline setting Improper needle settings
Engine starts and runs for several minutes, then dies	<ul style="list-style-type: none"> Bad glow plug Idle speed set too low Improper needle settings Overheated engine Glow plug failed due to lean engine setting

Troubleshooting Guide (cont.)

The Pro Boat™ Miss LLumar should provide many hours of exciting high-speed racing fun with just minor maintenance. Preventative maintenance is very important. Taking the time to ensure that all the set screws and bolts are tight before each operation of the boat will prevent many problems.

Before operating Miss LLumar

Check that all screws and hardware are securely in place. This is very important, as the manifold screws will occasionally vibrate loose during the first initial runs.

Check the propeller for damage in the form of chipping or cracking. If you find any damage, replace the propeller, as the damage will effect the performance of the boat and could also cause safety concerns.

When refueling, always wipe away any excess fuel that may have spilled into or on the boat.

After operating the Miss LLumar

Wipe off any exhaust residue from the boat. If you have operated Miss LLumar in salt water, it is suggested that you thoroughly rinse the deck, hull, and all the metal hardware with fresh water, then dry them with a clean rag or towel. This will help to prevent rust from occurring.

Ensure that the radio box and equipment inside is dry.

Section 6: Maintenance

Lubrication

It is important to lubricate the flex shaft of the Miss LLumar with silicone cable grease after every two hours of operation. Do not forget to do this. You can purchase this silicone grease at your local hobby store. To lubricate the drive shaft, follow these simple instructions.

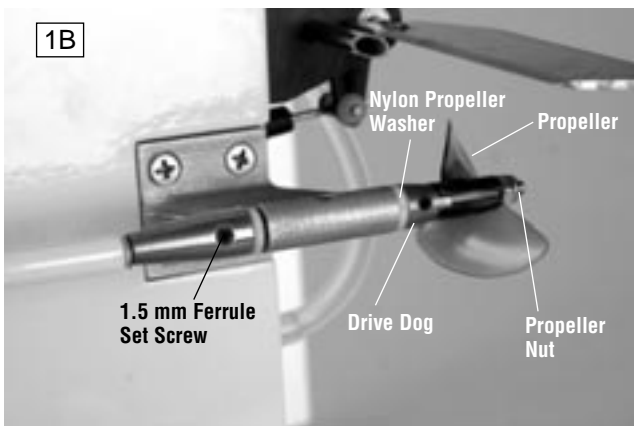
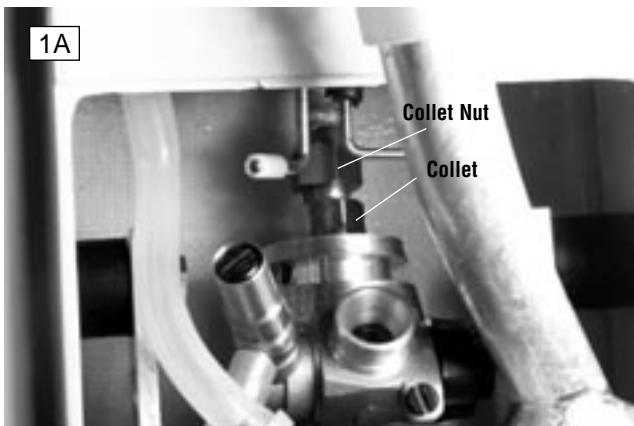

- Carefully note how the drive shaft and prop are presently installed. This is important so that when you have finished lubricating the drive shaft, you can correctly re-install the drive shaft.

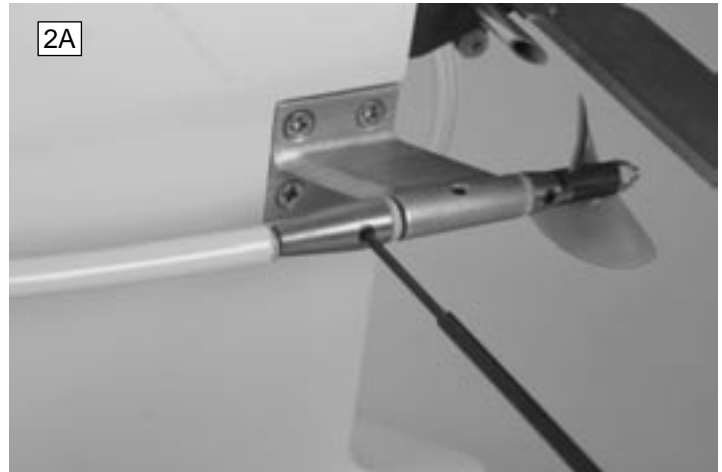

- Loosen and remove the ferrule screw that holds the propeller shaft. Remove the propeller and shaft from the aluminum strut.

Section 6: Maintenance (cont.)



- Loosen the 2 manifold bolts with your 2.5mm Allen wrench. Next insert your Allen driver into the hole located on the flywheel to lock the crankshaft in place. Then use an 11mm wrench to loosen the collet nut.



- Liberally lubricate the entire length of the flex shaft with silicone cable grease as shown.



- Carefully pull the ferrule away from the stuffing tube. You will need to pull at an angle to clear the aluminum strut.



- Carefully re-install the flex shaft and nylon bushing, making certain that you correctly tighten the collet nut. Next, re-install the drive shaft and propeller and tighten set screws on the flats of the drive shaft.



Section 7: Miss LLumar Replacement Parts

In the event that you need to purchase replacement parts for your engine or the Miss LLumar, please see your local hobby store. You can also purchase them from Horizon Hobby by calling **1-800-338-4639** or shop online @ www.horizonhobby.com

Stock #	Description	Stock #	Description	Stock #	Description
PRB2203	Exhaust Cover	PRB2218	Prop Nut	PRB2232	Boat Stand
PRB2207	Fuel Tank	PRB2219	Nylon Washer	PRB2501	Hull
PRB2208	Manifold	PRB2220	Rudder	PRB2502	Cockpit
PRB2209	Tuned Pipe	PRB2221	Rudder Bracket	PRB2503	Wing Strut
PRB2210	Manifold Pressure Fitting	PRB2222	Turn Fin	PRB2504	Sticker Sheet
PRB2211	Coupler Tubing	PRB2223	Push Rod Connector	PRB2505	Flex Shaft
PRB2212	Tuned Pipe Mount	PRB2224	Silicone Tubing	PRB2506	Drive Dog with Ferrule
PRB2213	Propeller	PRB2225	Battery Box/Switch	PRB2507	Aluminum Strut
PRB2215	Flywheel	PRB2226	Antenna Tube	PRB2508	Cable Collet
PRB2216	Drive Dog and Joint	PRB2228	Rubber Boot	PRB2509	Instruction Manual
PRB2217	Prop Washer	PRB2229	Cockpit Securing Nuts	PRB2510	Switch Mount
		PRB2231	Throttle Push Rod	PRB2511	Motor Mounts w/Hardware

Appendix

Photo 1

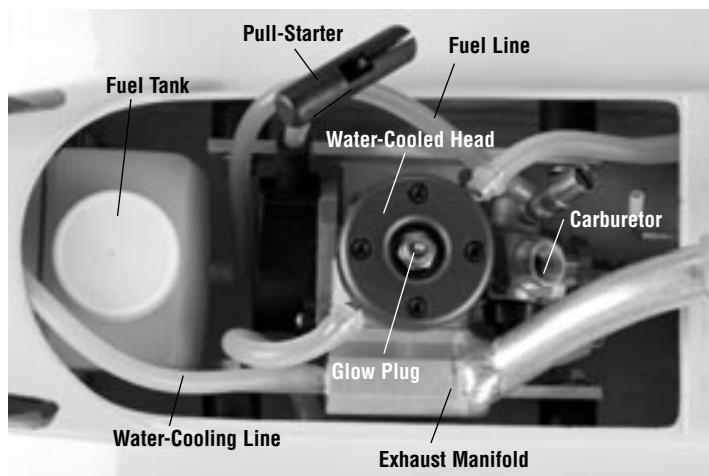

Photo 3

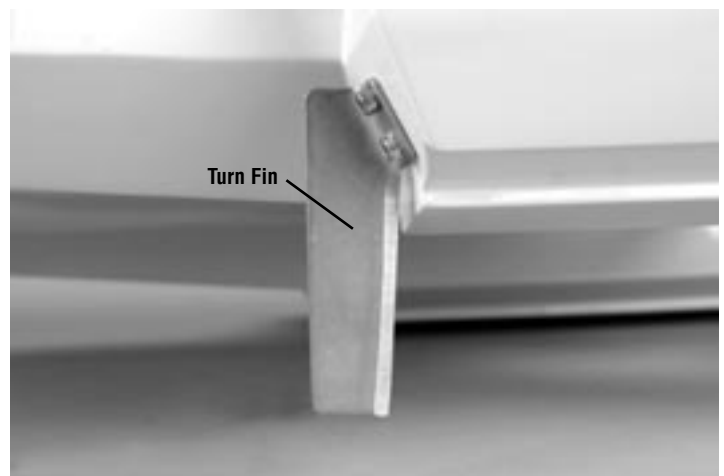

Photo 2

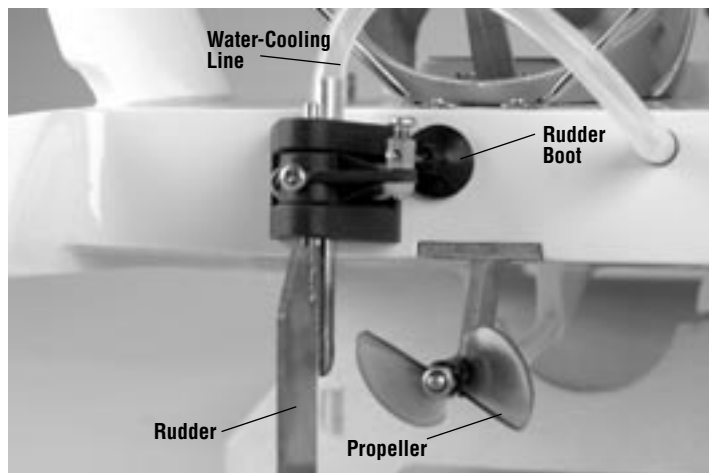
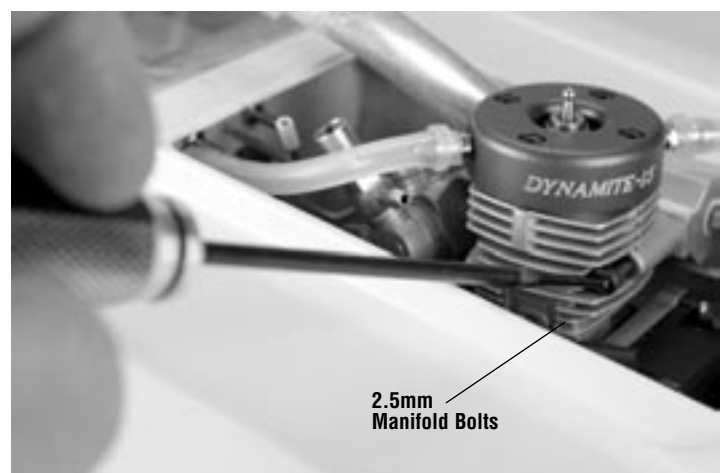

Photo 4



Look for these other fine Pro Boat™ models at your local hobby dealer.



- Professionally painted and detailed fiberglass hull
- Speeds up to 30 mph
- Water-cooled Dynamite® .15 marine nitro engine
- JR® Python pistol-grip radio system installed
- Length: 27.5 inches

PRB2200 Miss Budweiser 1/12 Unlimited Hydro RTR



- JR XR3i FM pistol-grip radio system installed
- Professionally painted and decaled fiberglass hull
- Zenoah® G26 marine engine installed
- Stock speeds in excess of 40 mph
- Length: 44.25 inches

PRB2250 Miss Budweiser 1/8 Unlimited Hydro RTR

- JR XR3i FM pistol-grip radio system installed
- Professionally painted and decaled fiberglass hull
- 26cc Zenoah G26 marine engine
- Length: 55 inches
- Genuine Prather running hardware



PRB2000 ShockWave™ 55" Deep-V RTR with Zenoah G-26

- Preinstalled JR Beat Gear 2-stick 2-channel system with sail winch
- Handcrafted fiberglass composite hull
- Detachable 2-piece mast of anodized aluminum
- Assembles in under 2 hours
- Length: 36 inches



PRB2400 Sanibel™ 36-600 RTR Sailboat

- Equipped with a fan-cooled 550-size motor, waterproof electronic speed control with reverse, two-stick FM transmitter and a painted vinyl rider figure
- Extra-wide 9-inch beam



PRB2300 Riptide™ Watercraft EP RTR



PRB2240 1/12 Miss Budweiser Boat Tote

