

Pipe Cub J-3



No. EP-37

SPECIFICATIONS

WING SPAN: 1400 mm

WING AREA: 28 dm²

LENGTH: 1260 mm

WEIGHT: 1050g

RADIO: 4 Ch

MOTOR: SF1000KV

ESC: 30A

BATTERY: Li-Po 3 cells

PROPELLER: 11 x 5.5

THRUST POWER: 1260g

INSTRUCTION MANUAL

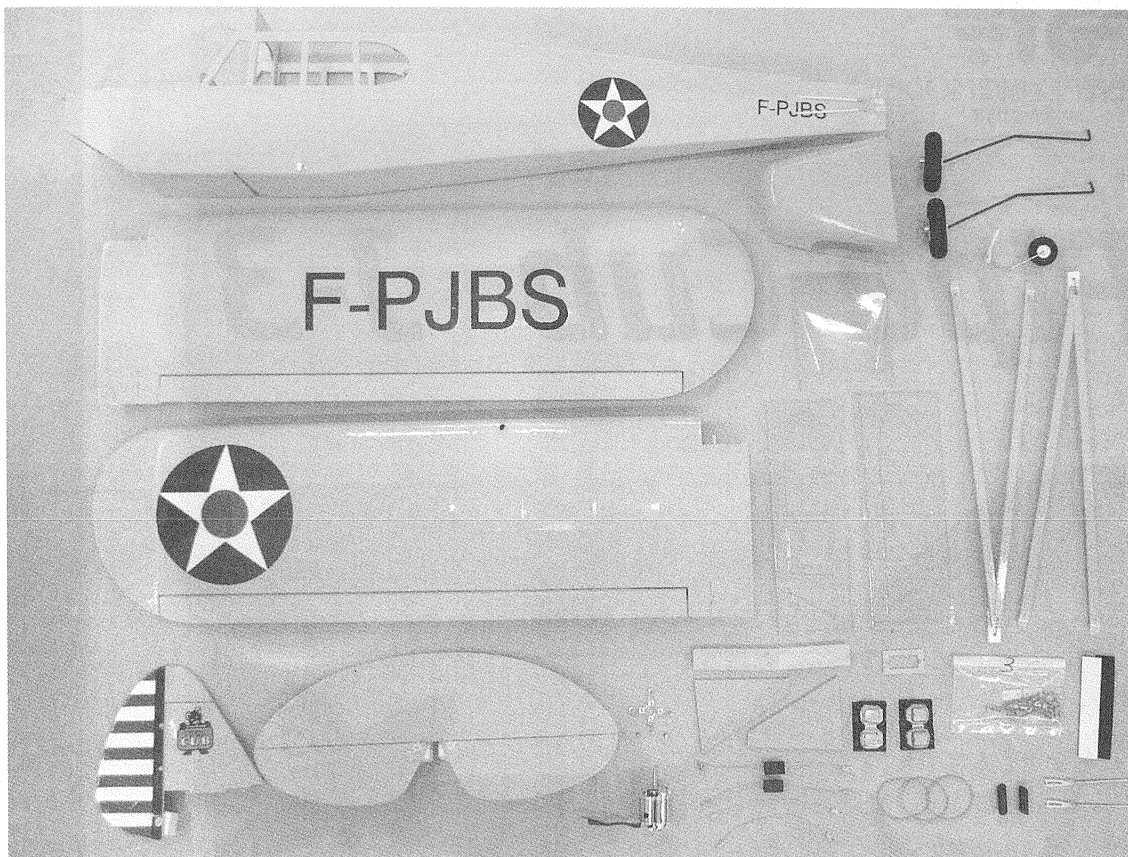

The whole accessories including in this kit.

Recommended radio and electronic equipment (Not included in kit):

Motor: 1000KV brushless motor

Propeller: 11 x 5.5

ESC: 30A

Servos: 13g x 3 pcs

Extension: 30cm x 2 pcs

Y-harness x 1 pc

Radio: 4 channels

Battery: 2000mAh LiPo

10 cells NiMH

Tools and suppliers needed (not included in kit):

Z bender

1.5mm hex wrench

Phillips screw driver

Hobby knife, pencil

Nipple pliers

Hobby scissors

2mm driller

Epoxy

Instant glue.

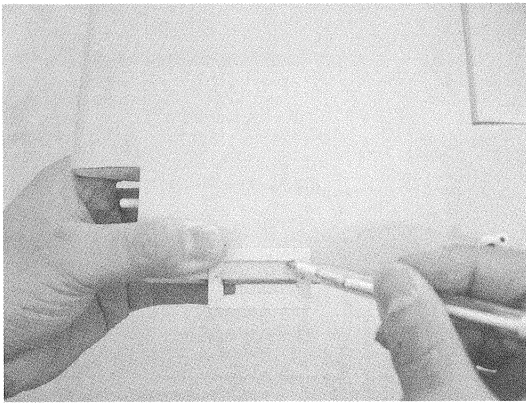

Place the servo tray on the bottom of the main wing. When satisfy the location, use pencil to trace the inside of the tray.

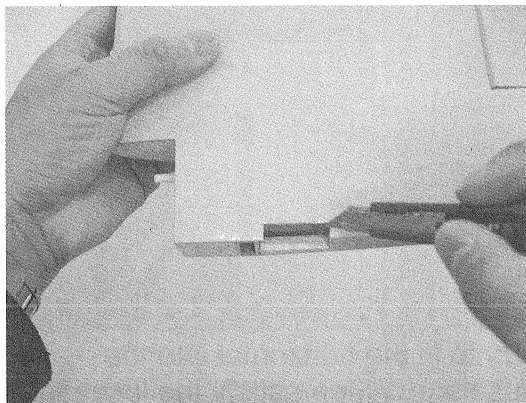

Use hobby knife to cut off the planking inside the marking area carefully.

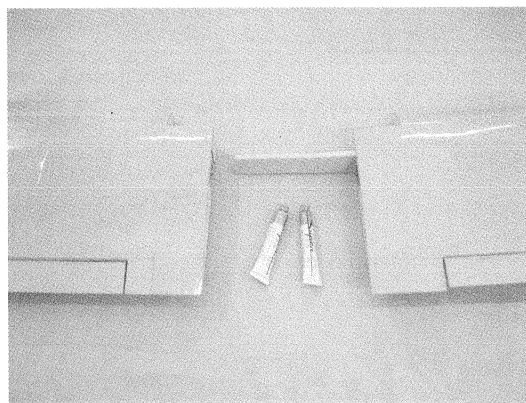

Spread generous epoxy on the wing join. Insert the wing joiner into the other wing half and wait for the glue to dry enough.

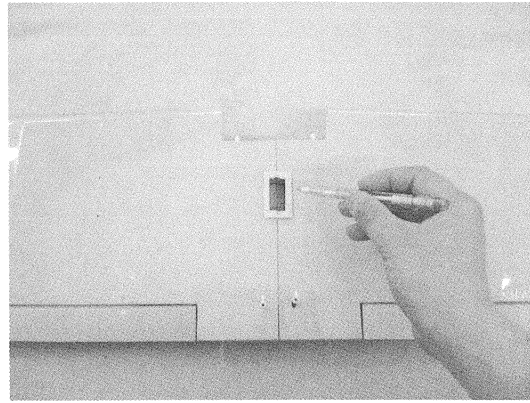

Place the servo tray again on the same location. Use pencil to trace the inside of the tray.

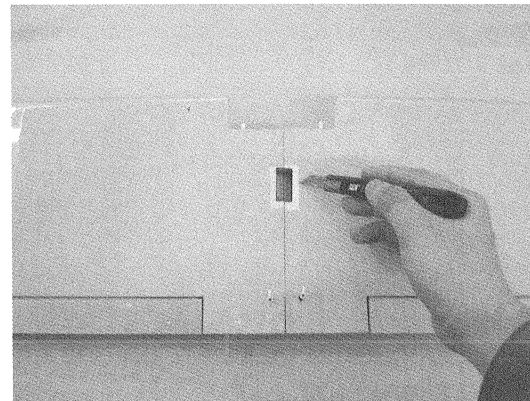

Use hobby knife to cut off the covering inside the marking area carefully.

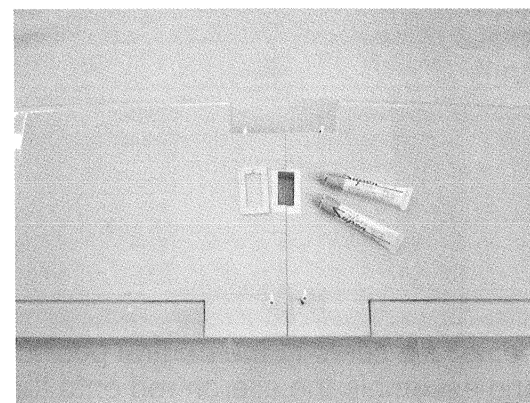

Use epoxy to glue the servo tray on the main wing.

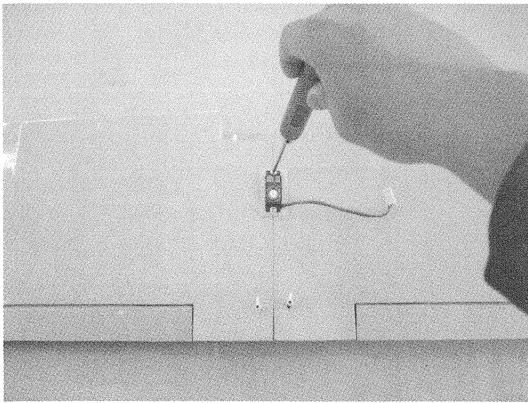

Secure the servo on the servo tray.

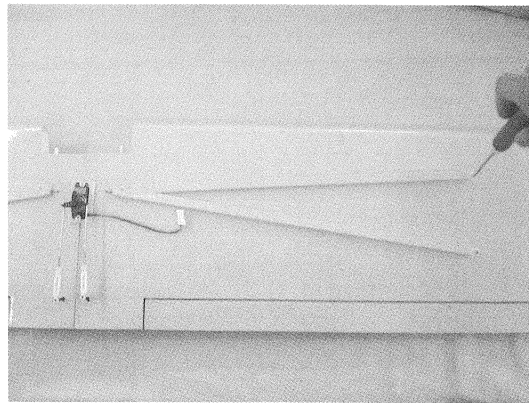

Use 2.6 x 10mm tapping screw to secure the strut on the main wing.



Use Z-bender to make a Z on one end of the aileron rod.

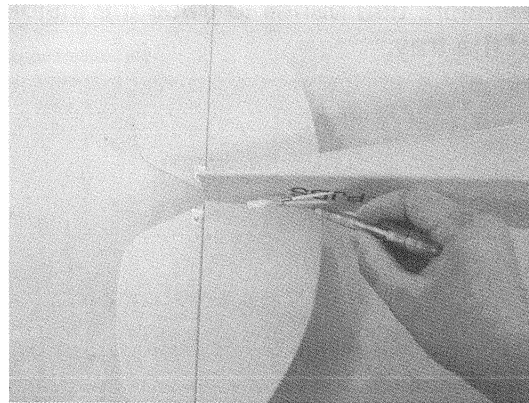

Try to fit the horizontal into the fuselage. When satisfy the location, use pencil to mark the contacting area on the horizontal.

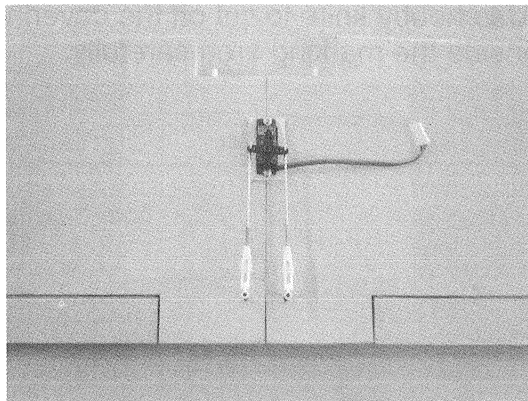

Adjust the servo to the neutral position and assemble the aileron rod onto the servo.

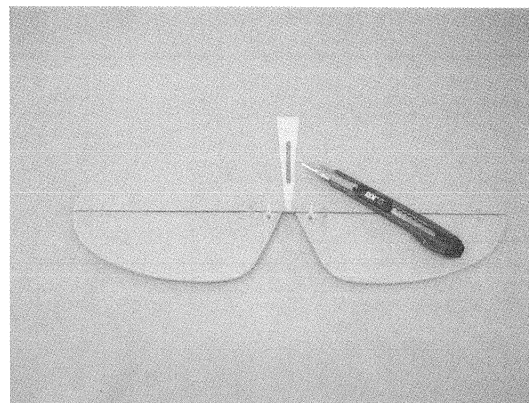

Use hobby knife to cut off the covering inside the marking area carefully. Don't cut into the wood.

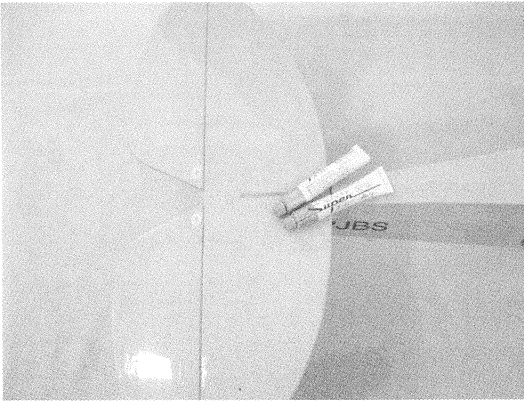

Spread generous epoxy on the marking area and insert the horizontal into the fuselage. Wait for the glue to dry enough.

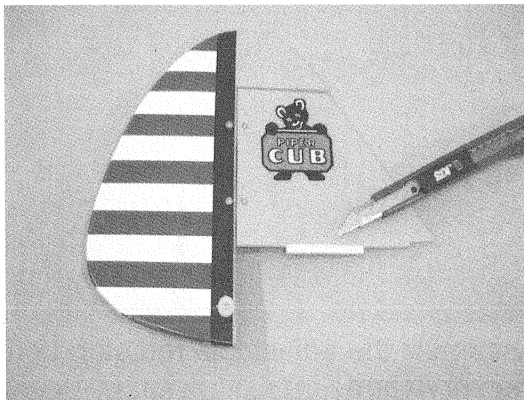

Use hobby knife to cut off the covering on the vertical that will contact with horizontal after assembly.

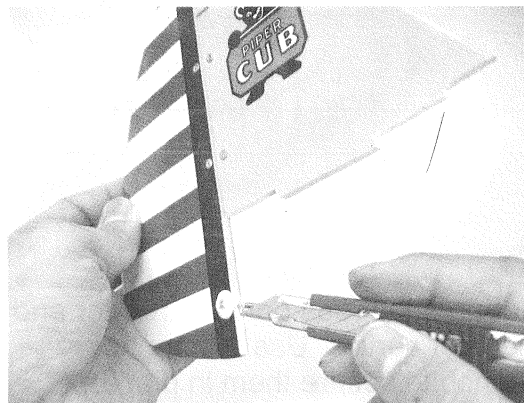

Use hobby knife to cut a slot of 1.7 x 1.7mm for installing the tail gear.



Install the tail gear assembly into the slot. Use instant glue to secure it in place.

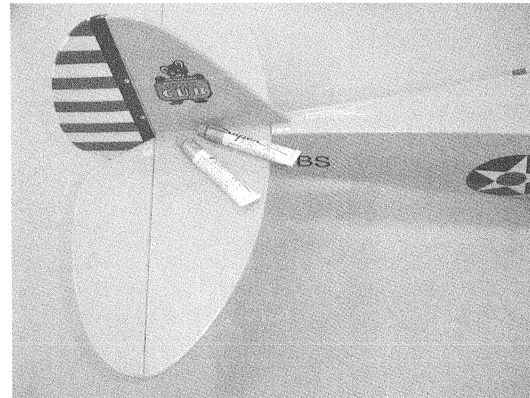

Use epoxy to glue the vertical onto the horizontal.

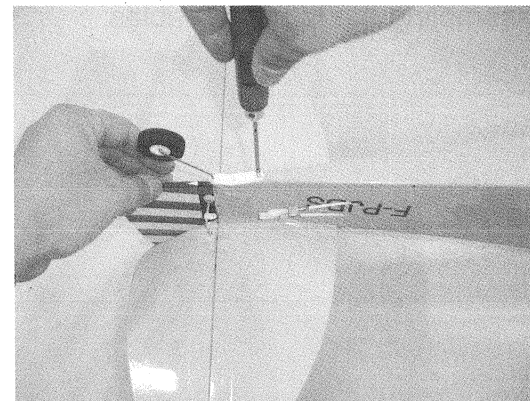

Use 2.6 x 10mm tapping screw to secure the gear plate in place.

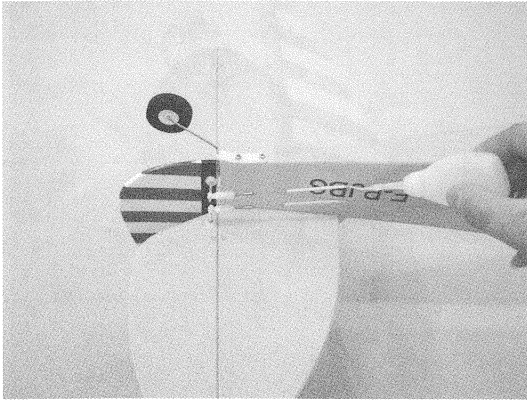

Assemble the rods for horizontal and vertical. Use instant glue to secure the rods tube on the fuselage.

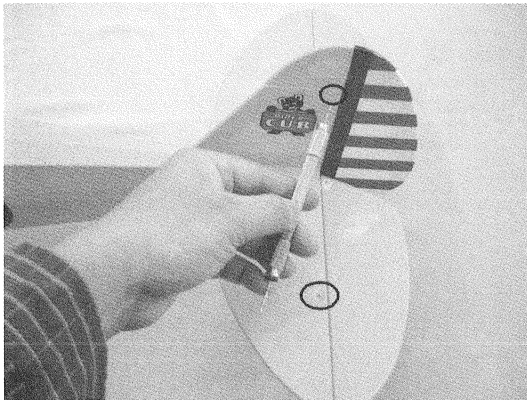

Use 2.0mm driller to open holes on the vertical and horizontal for assembling the tail wing cables.

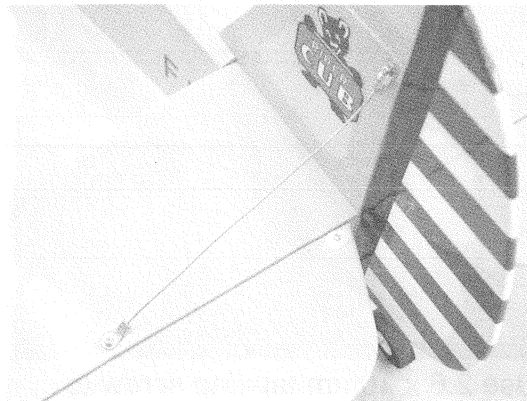

Use M2.0 x 8mm screws, 6mm plates and M2 nuts to secure the cables on the vertical and horizontal. Please refer to the picture.

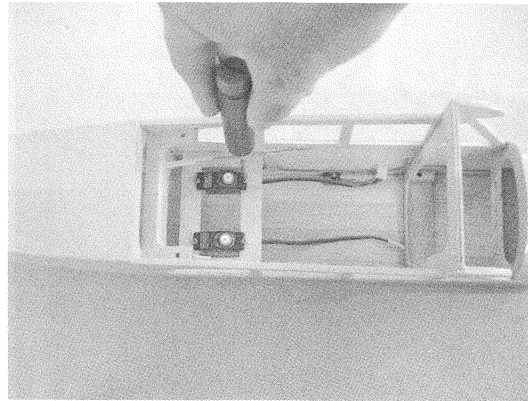

Assemble the servos for the elevator and rudder.

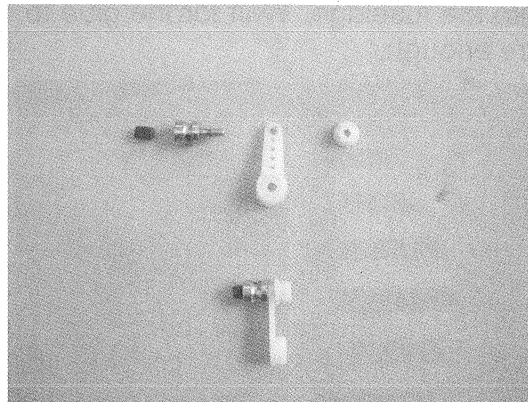

Assemble the adjustable rod stand on the servo arm.

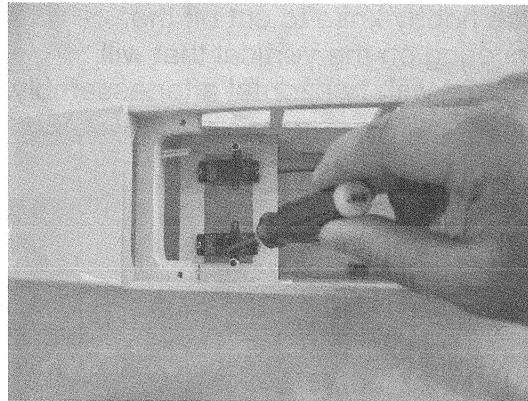

Connect the rods onto the rudder and elevator servos. Use 1.5mm hex wrench to secure them in place.

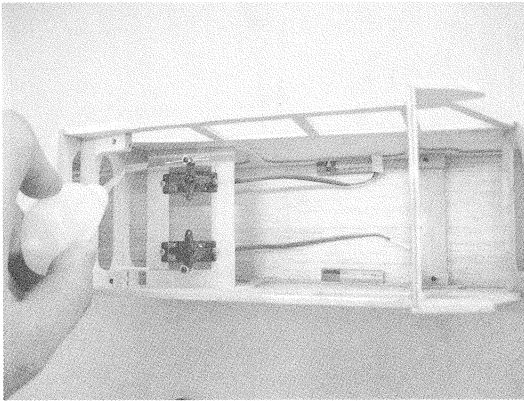

Pull the tubes straight and use instant glue to secure them inside the fuselage.

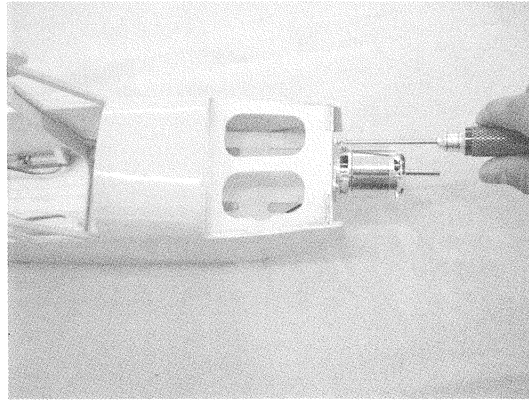

Use 2.6 x 10mm tapping screws to secure the motor on the nose.

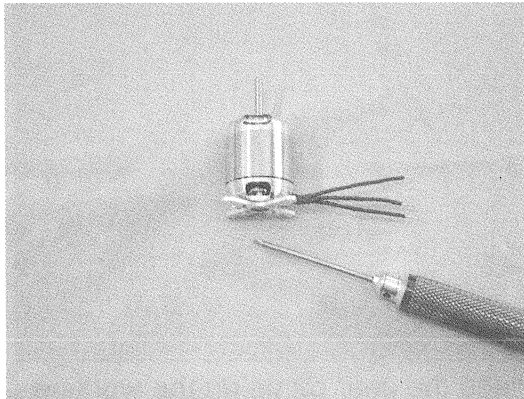

Assemble the cross stand onto the brushless motor.

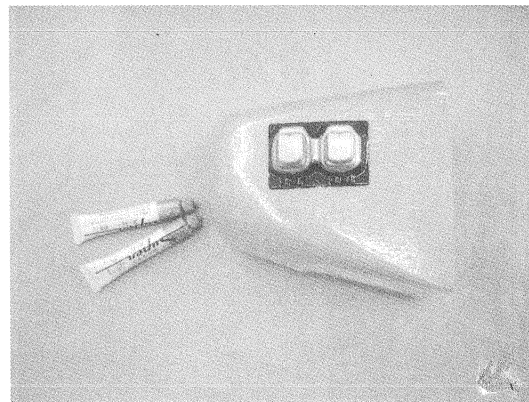

Use epoxy to glue the cowling on the nose.

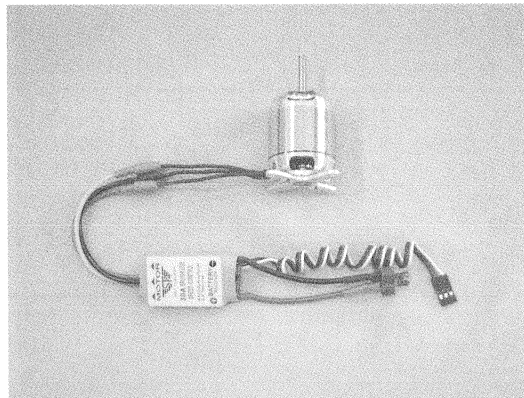

Connect the motor with the ESC
Please note the rotation of the motor.

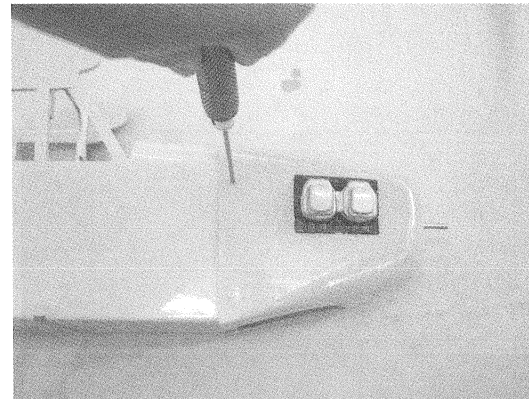

Use 2.0 x 6mm tapping screws to secure the cowling in place.

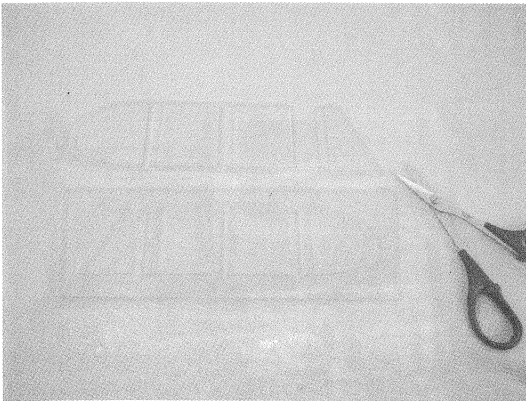

Use hobby scissors to trim the windows.

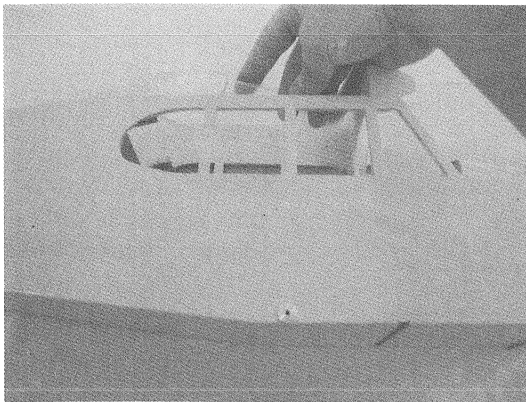

Use epoxy to glue the side windows in place.



Try to place the front window on the fuselage. When satisfy the location, use tape to secure the front window in place.

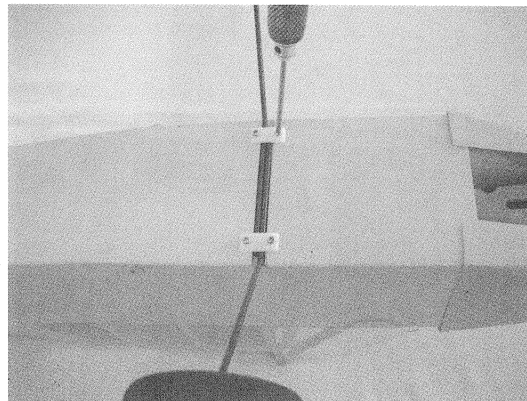

Use 2.6x10mm tapping screws and plates to secure the main gear in place.

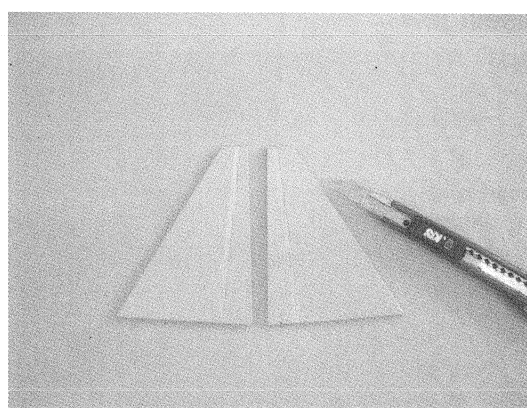

Place the gear pants on the working table. Use hobby knife to cut the tooling line on the pants.

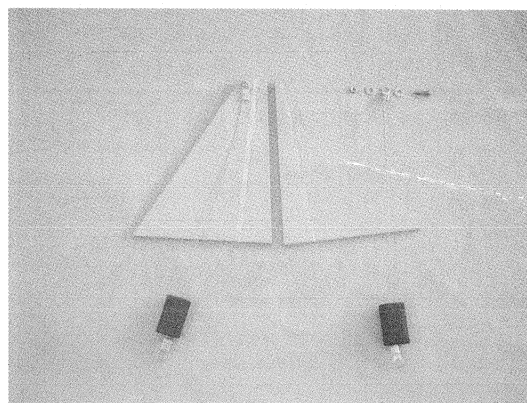

Use 2mm driller to open a hole on the gear pants. Use M2 screw, 6mm plate and M2 nut to secure one end of the gear cable on the pant.

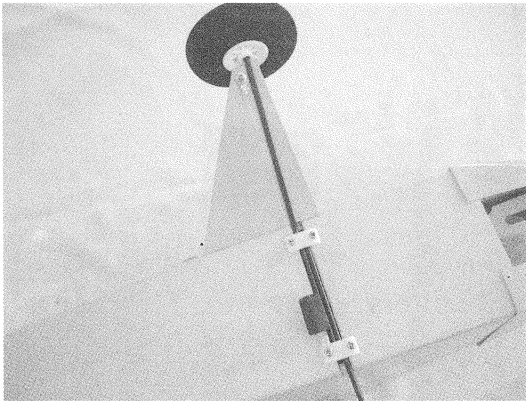

Secure the other end of the gear cable on the screw of the main gear plate.

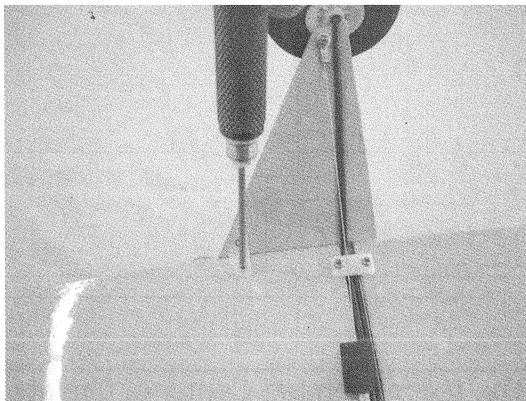

Use 2.0 x 6mm tapping screws and hinges to secure the gear pants onto the fuselage.

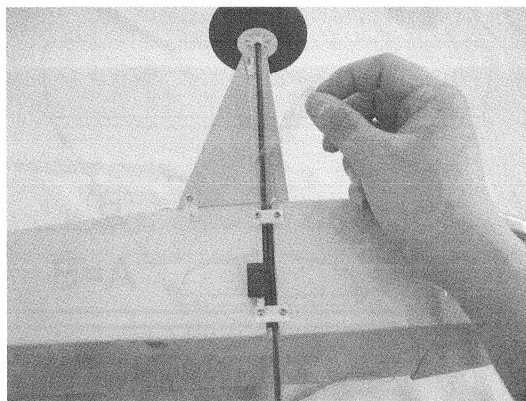

Apply 15mm x 100mm decal to fix the main gear onto the gear pants.

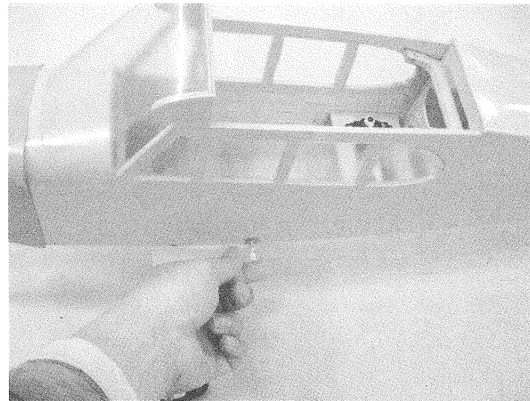

Assemble the rod connector.

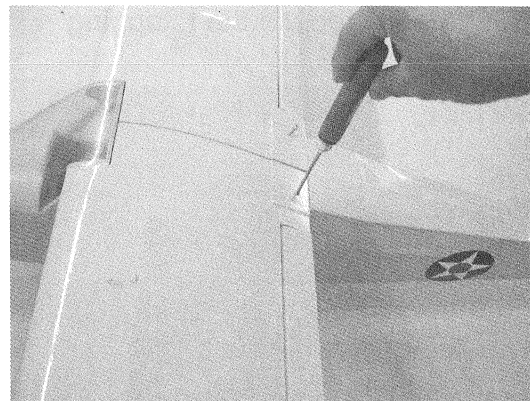

Use M3 x 40mm bolts to secure the main wing on the fuselage.

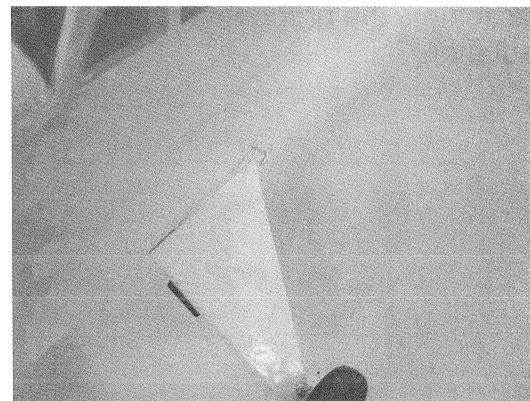

Screw in the L tapping screw.

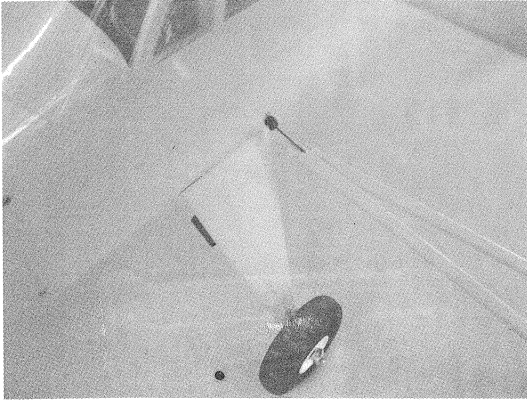

Place O-rubber ring on it. The length can be adjusted via the L tapping screw.

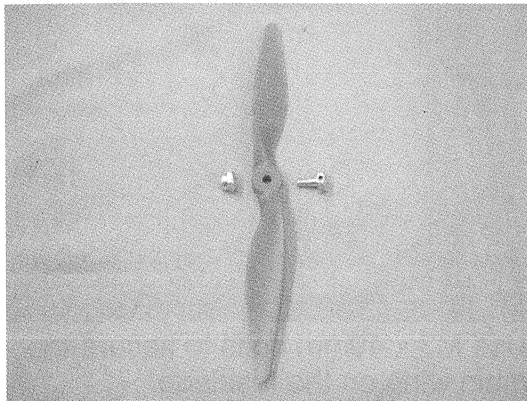

Assemble the propeller with aluminum adaptor.

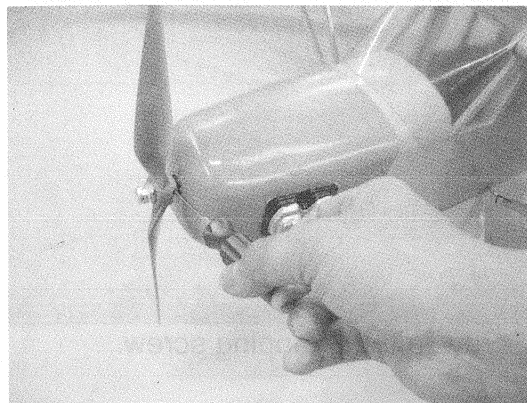

Install the propeller onto the motor. Use 1.5mm hex wrench to secure the propeller in place.

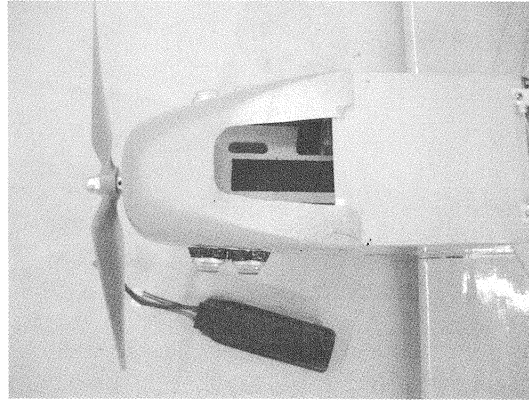

Use a piece of hook and loop between the battery and battery tray.

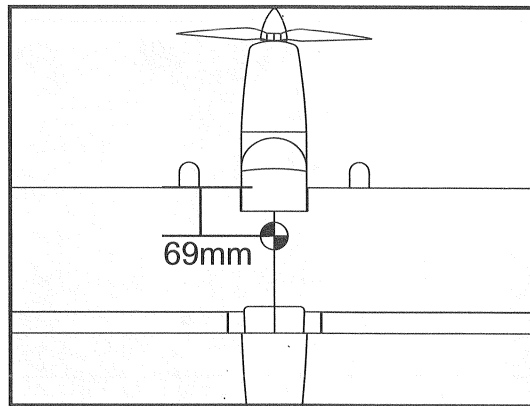

The recommended Center of Gravity location is 69mm back from the leading edge against the fuselage.

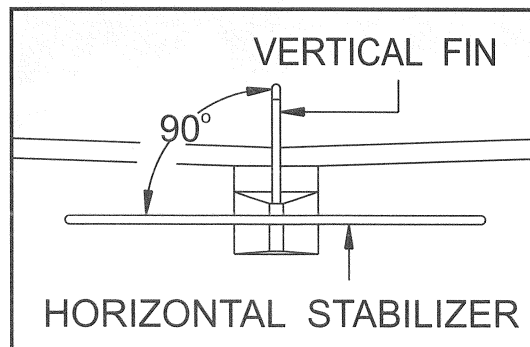
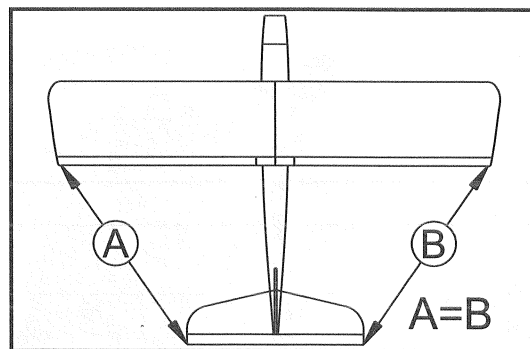

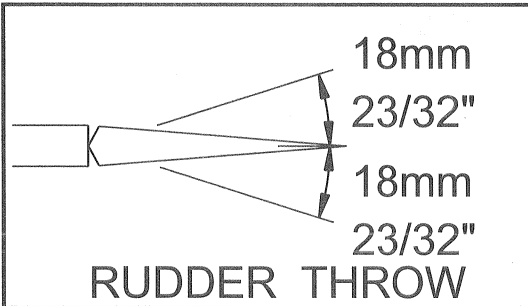
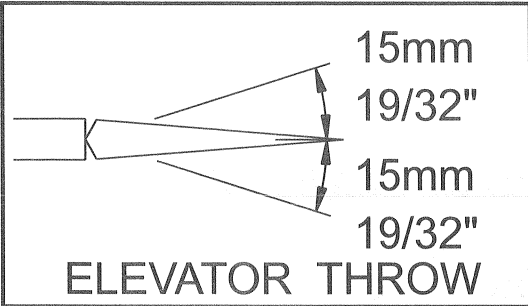
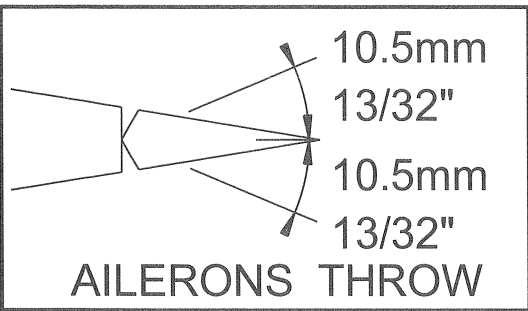

THE CABLE CONNECTION DIAGRAM

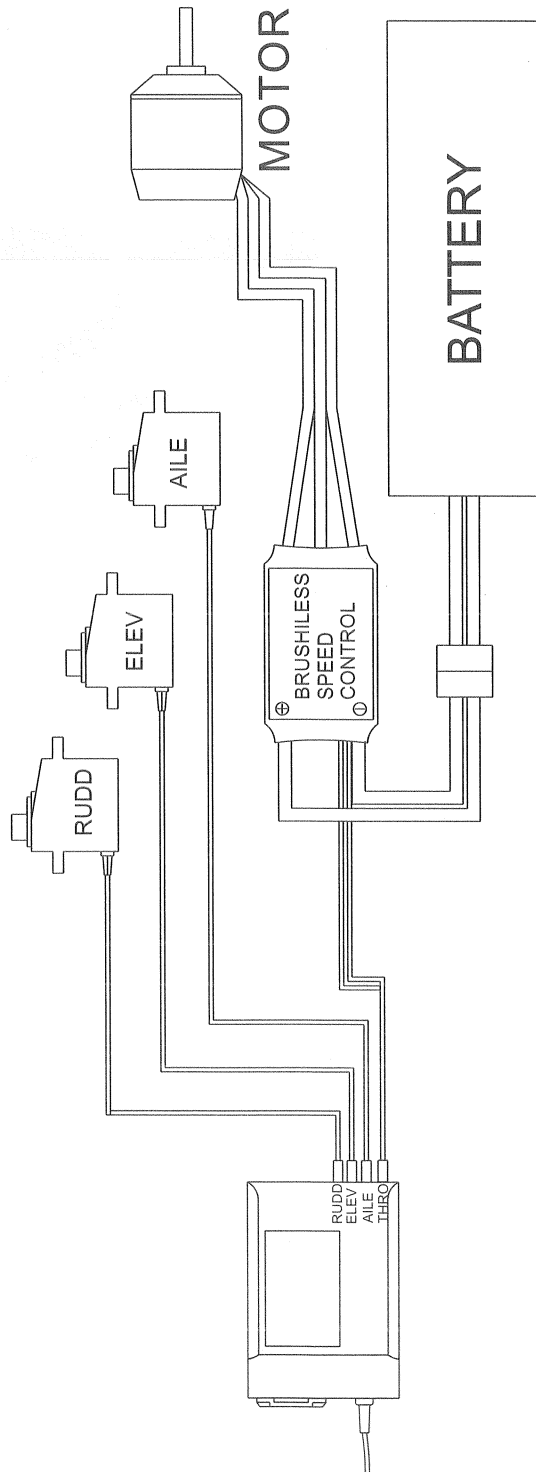



SUPER FLYING MODEL
MANUFACTURE

MTH HOBBY PRODUCTS INDUSTRIAL CO., LTD.
www.mth.com.tw mthhobby@mth.com.tw
© MTH HOBBY 2009