

AR6400 User Guide

The AR6400 6-channel Ultra-Micro™ receiver with integrated servos, speed control and X-Port™ technology is designed for ultra-micro aircraft. Featuring DSM2™ technology the AR6400 is compatible with all Spektrum™, JR®, E-flite® and ParkZone® 2.4GHz DSM2 technology transmitters including: Spektrum DX7, DX6i, DX5e, Spektrum Module Systems, JR12X, JRX9303, E-flite LP5DSM, E-flite HP6DSM, E-flite MLP4DSM and ParkZone's 2.4GHz DSM2 Transmitter.

US Patent D578,146. Other Patents Pending.

Note: The AR6400 receiver is not compatible with the DX6 park flyer radio system.

Features

- **6-channel Ultra-Micro receiver**
- **Two integrated linear servos (elevator and rudder)**
- **Integrated brushed speed control**
- **Compatible with external brushless speed controls (optional)**
- **Weighs just 3.9 grams**
- **Compatible with optional Spektrum 1.5-gram linear ultra-micro servos SPMAS2000**
- **Smart Bind™ technology**
- **X-Port allows for future expansion**

Applications

The AR6400 is designed for ultra-micro aircraft and is ideal for scratch-built ultra-micro projects. The AR6400 is designed to utilize a single cell LiPo battery. Two sizes are available, EFLB1101S 3.7V 110mAh, PKZ3001 3.7V 70mAh and PKZ1034 3.7V 110mAh. An integrated brushed speed controller can be used to power a brushed motor up to 2 amps of continuous current or an optional brushless controller can be used. An integrated X-Port feature allows for future expansion.

Note: when X-Port is active, CH5 and CH6 are not available; however, reversed aileron (CH2) is still available.

Specifications:

- Type:** DSM2 micro receiver with integrated brushed speed controller and two linear servos
- Channels:** 6 channels or 4 channels plus X-Port
- Modulation:** DSM2
- Dimension (WxLxH):** 27.75 x 23.45 x 8.10mm
- Weight:** 3.9 g
- Input Voltage Range:** 1-cell LiPo 3.2 to 4.2V
- Antenna Length:** 31mm
- Resolution:** 1024
- Compatibility:** All DSM2 aircraft transmitters

Servos:

- Force:** 2.8 oz
- Stroke:** 7.4mm
- Speed:** 0.14 sec

Speed Controller:

- Type:** Integrated brushed
- Max continuous current:** 2.0 amps

AR6400 Features and Ports

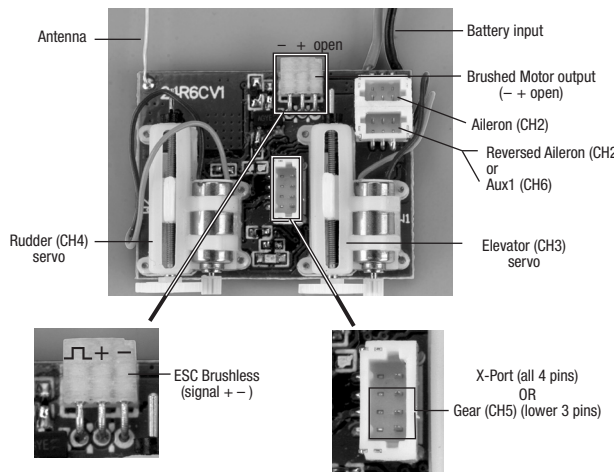

Receiver Installation

It is recommended to use double-sided foam tape strips and/or minimal hot glue in the corners to install your receiver in the fuselage. Note that the servos need to be in the appropriate position to attach to and drive the elevator and rudder pushrods. Note: Installation will vary depending upon application.

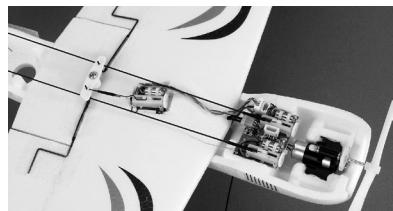

Servos

The AR6400 incorporates integrated servos; optional servos are also available through Spektrum (SPMAS2000). Note that using any other servo may cause damage to the receiver and/or the servo and may void the warranty.



Optional Servo (SPMAS2000)

Installing and Plugging in the Optional Servos

Use double-sided foam tape strips and/or minimal hot glue to mount the servos in place. Note that the servos need to be in the appropriate position to attach to the corresponding pushrods. Plug the servo leads into the appropriate servo ports in the receiver noting the polarity of the servo connector. Note: Installation will vary depending upon application.

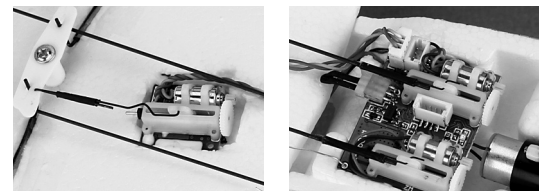

Smart Bind™

The AR6400 receiver must be bound to the transmitter before it will operate. Binding is the process of teaching the receiver the specific code of the transmitter so it will only connect to that specific transmitter. The AR6400 features Smart Bind. When the receiver is first powered, the receiver will look for the signal of its previously bound transmitter for 5 seconds. If no signal is found the receiver will automatically go into bind mode indicated by the flashing LED.

Binding

1. Make sure the flight battery is fully charged.
2. Confirm the flight battery is disconnected from the receiver/ESC unit and the transmitter is turned off.
3. Plug the flight battery into the receiver's battery connector. After 5 seconds the LED on the receiver unit will begin flashing indicating it is in bind mode.

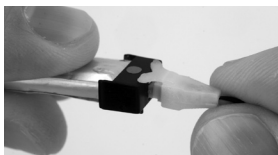

4. After verifying the LED is flashing on the receiver, follow the steps necessary that allow your transmitter to enter bind mode. (See your transmitter's manual or the supplement on the following pages.)

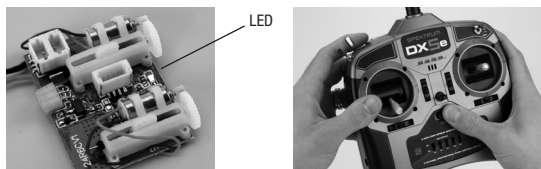

5. If you entered bind mode correctly, you will see a solid LED within about 10 seconds. You should now be bound to the transmitter and have full control and function.

IMPORTANT: After Binding

Once the system is bound, the transmitter should always be turned on first and then the receiver to prevent the receiver from re-entering bind mode. If your receiver inadvertently enters bind mode, simply unplug the battery from the receiver and reinstall with the transmitter remaining on.

Advanced Programming Features

The following programming features are only recommended for advanced radio users. To safely accomplish advanced programming feature changes, please enlist the use of a helper. One to hold the aircraft to prevent unintended flyaways, and one to make the changes on the transmitter. The photos in this section show the E-flite MLP4DSM transmitter, however, the procedures apply to all compatible transmitters. Prior to making any advanced programming feature changes it is necessary to:

Computer Radios like the DX6i, DX7

1. Choose an empty model location
2. Select model type ACRO
3. Perform a model reset
4. Set all channels to normal reversing
5. Ensure a successful bind has been established

Note: Please secure the aircraft safely to a work bench or enlist the use of a helper while accessing the advanced programming features. Mistakes in programming could cause the motor to run unexpectedly.

LP5DSM, HP6DSM

If you decide to use an E-flite LP5DSM or HP6DSM transmitter, please position your channel reversal dip switches as follows:



LP5DSM Transmitter

HP6DSM Transmitter

Note: Keep a record of the existing settings in case you want to go back and fly your other aircraft.

Reversing Servos
Servo reversing may be achieved using the servo reversing function of your transmitter, or as certain advanced applications require it, you may reverse the actual servos by following the instructions and diagrams below.

Reversing The Servos on the Receiver Board

This feature reverses the servos at the board level, making it useful for implementing features such as elevons while using transmitters with limited programming options.

Note: All changes made in advanced programming must start with the receiver powered down to prevent the motor from running unexpectedly.

To safely accomplish advanced programming feature changes, please enlist the use of a helper. One to hold the aircraft to prevent unintended flyaways, and one to make the changes on the transmitter.

Sticks must be held in this position while the transmitter is on and the receiver is off.

1. Ensure a successful bind was completed
2. Turn transmitter on
3. Move THRO stick to full throttle position
4. Move control sticks to the corresponding position for the servo to be reversed (see illustration)
5. While holding this position, plug the battery into the receiver, power receiver
6. The LED on the receiver will go solid and within 5 seconds the LED will flash 3 times quickly, indicating servo is now reversed
7. Disconnect battery from receiver
8. Turn transmitter off

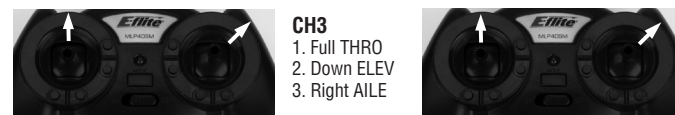

Reversing Optional 1.5-Gram Servo

Reversing the servo is useful when implementing certain installations, such as dual ailerons, flaps, etc. Spektrum offers a servo reversing lead that can be plugged between the receiver and the optional 1.5-gram servo.

Note: All changes made in advanced programming must start with the receiver powered down to prevent the motor from running unexpectedly.

To safely accomplish advanced programming feature changes, please enlist the use of a helper. One to hold the aircraft to prevent unintended flyaways, and one to make the changes on the transmitter.

To reverse servo using the reversing lead:

1. Plug the reversing lead into the servo
2. Plug servo into CH2 or Reversed CH2/CH6 ports
3. Power receiver using a charged battery
4. Once receiver connects, the servo is now reversed
5. Disconnect battery from receiver
6. Remove servo reversing lead (be sure to store your reversing lead in a safe place for future use)
7. Reinstall servo lead into servo port

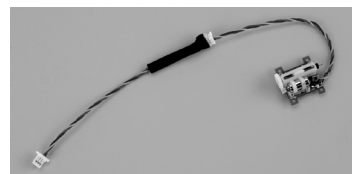

To Change Channel 6 to a Reversed Channel 2 for Dual Ailerons or Reversed Channel 2 to Channel 6

Note: All changes made in advanced programming must start with the receiver powered down to prevent the motor from running unexpectedly.

To safely accomplish advanced programming feature changes, please enlist the use of a helper. One to hold the aircraft to prevent unintended flyaways, and one to make the changes on the transmitter.

Sticks must be held in this position while the transmitter is on and the receiver is off.

1. Ensure a successful bind was completed
2. Turn transmitter on
3. Move THRO stick to full throttle position
4. Move THRO stick to the corresponding position to change between the available options (see illustration)
5. While holding this position, plug the battery into the receiver, power receiver
6. The LED on the receiver will go solid and within 5 seconds the LED will flash 3 times quickly, indicating the option is now changed
7. Disconnect flight pack from receiver
8. Turn transmitter off



To Change the Brushed Motor to Operate an Optional Brushless Motor ESC or Brushless to Brushed Motor Control

The AR6400 is capable of operating brushless motors with the use of an optional brushless ESC, please see the illustration below for instructions.

Sticks must be held in this position while the transmitter is on and the receiver is off.

1. Ensure a successful bind was completed
2. Turn transmitter on
3. Move THRO stick to full throttle position (see illustration)
4. Move Control sticks to the corresponding position to change between the available options (see illustration)
5. While holding this position, plug the battery into the receiver, power receiver
6. The LED on the receiver will go solid and within 5 seconds the LED will flash 3 times quickly, indicating the option is now changed
7. Disconnect battery from receiver
8. Turn transmitter off

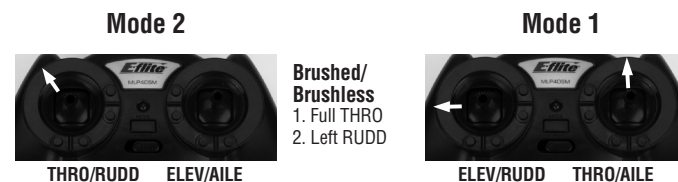

To Change Channel 5 to X-port or X-port to Channel 5

Note: When X-Port is active, CH5 and CH6 are not available; however, reversed aileron (CH2) is still available.

Note: All changes made in advanced programming must start with the receiver powered down to prevent the motor from running unexpectedly.

To safely accomplish advanced programming feature changes, please enlist the use of a helper. One to hold the aircraft to prevent unintended flyaways, and one to make the changes on the transmitter.

Sticks must be held in this position while the transmitter is on and the receiver is off.

1. Ensure a successful bind was completed
2. Plug the X-Port accessory or the optional servo into the X-Port/CH5
3. Turn the transmitter on
4. Move the THRO stick to the full throttle position
5. Move Control sticks to the corresponding position to change between the available options. (see illustration)
6. While holding this position, plug the battery into the receiver, power receiver
7. The LED on the receiver will go solid and within 5 seconds the LED will flash 3 times quickly, indicating the option is now changed
8. Disconnect battery from receiver
9. Turn transmitter off

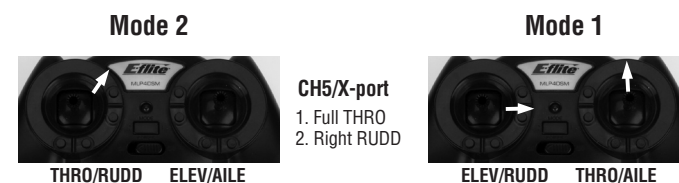

Optional Support Items

- PKZ3502** Propeller with Spinner: Sukhoi (160mm x 70mm)
- PKZ3516** Motor: Sukhoi (8.5mm diameter, 20mm length)
- PKZ3527** Gearbox without Motor: Sukhoi (Gear ratio 4:1)
- PKZ3528** Propeller Shaft: Sukhoi
- PKZ3302** Propeller with Spinner: Vapor (140mm x 45mm)
- PKZ3316** Main Motor: Vapor (6.0mm diameter, 15mm length)
- PKZ3327** Gearbox without Motor: Vapor (Gear ratio 6:1)
- PKZ3328** Propeller Shaft with Gear (2): Vapor
- PKZ1034** 110mAh 1S 3.7V LiPo: Sukhoi
- PKZ3001** 3.7V 70mAh LiPo Battery: Cessna 210, Citabria, Ember/2, Vapor
- EFLB1101S** 110mAh 1S 3.7V LiPo: Blade mCX
- EFLC1003** 1S 3.7V LiPo Charger, 0.3A: Blade mCX
- EFLC1004** E-flite Celecra 4 Port Charger for 1C 3.7V LiPo battery packs
- PKZ3240** DC 3.7V LiPo Charger

Transmitter Specific Binding Instructions

DX5e:

1. To bind your AR6400 to the DX5e, plug the battery into the receiver. The LED on the receiver will begin flashing.
2. Move the sticks and switches on the transmitter to the desired failsafe positions (low throttle and neutral control positions).
3. Pull and hold the Trainer Switch on the transmitter while turning the transmitter on. Release the trainer switch once the LEDs on the front of the transmitter flash.
4. The LED on the receiver will go solid and the system will connect after several seconds.

DX6i:

1. To bind your AR6400 to the DX6i, plug the battery into the receiver. The LED on the receiver will begin flashing.
2. Move the sticks and switches on the transmitter to the desired failsafe positions (low throttle and neutral control positions).
3. Pull and hold the Trainer Switch on the transmitter while turning the transmitter on. Release the trainer switch once the word BIND flashes on the LCD screen on the front of the transmitter.
4. The LED on the receiver will go solid and the system will connect after several seconds.

DX7 (includes DX7se):

1. To bind your AR6400 to the DX7, plug the battery into the receiver. The LED on the receiver will begin flashing.
2. Move the sticks and switches on the transmitter to the desired failsafe positions (low throttle and neutral control positions).
3. Press the bind button on the back of the transmitter while turning the transmitter on. The bind button on the back of the transmitter will flash. Release the button after 2-3 seconds.
4. The LED on the receiver will go solid and the system will connect after several seconds.

Trouble Shooting Guide

Problem	Possible Cause	Solution
Aircraft will not "throttle up" but all other controls seem to function.	<ul style="list-style-type: none">• User did not lower throttle trim and throttle stick prior to initializing the aircraft.• Throttle channel is reversed.• Note: Futaba transmitters (equipped with Spektrum modules) may require you to reverse the throttle channel.• Is the Brushed/Brushless option correctly selected for the power system?	<ul style="list-style-type: none">• Lower throttle stick and throttle trim to their lowest settings.• Reverse throttle channel on specific transmitter if applicable. • Change to the correct power system (brushed or brushless).
LED on aircraft remains flashing and cannot be controlled by transmitter.	<ul style="list-style-type: none">• User did not wait at least 5 seconds after powering the transmitter prior to connecting the flight battery to the aircraft.• User bound the aircraft to a different transmitter. • Transmitter was too close to aircraft during the initialization process.	<ul style="list-style-type: none">• Unplug, then reconnect flight battery. • Rebind aircraft to your desired compatible transmitter.• Move transmitter (powered on) a few feet from the aircraft prior to reconnecting the flight battery.
Controls appear to be reversed after binding to a different transmitter.	<ul style="list-style-type: none">• User did not initially set up their transmitter prior to binding to the aircraft.	<ul style="list-style-type: none">• See the "Advanced Programming" section of this manual.
Aircraft does not function after connecting flight battery and aircraft smells burnt.	<ul style="list-style-type: none">• User may have accidentally plugged the flight battery in the wrong polarity.	<ul style="list-style-type: none">• Replace AR6400 board (SPMAR6400) and ensure the RED polarity marks are facing the same direction when connecting the flight battery to the AR6400 board.

Tips on Using Spektrum 2.4GHz

ModelMatch™

Some Spektrum and JR transmitters offer a patent pending feature called ModelMatch. ModelMatch prevents the possibility of operating a model using the wrong model memory, potentially preventing a crash. With ModelMatch each model memory has its own unique code (GUID) and during the binding process the code is programmed into the receiver. Later, when the system is turned on, the receiver will only connect to the transmitter if the corresponding model memory is programmed on screen.

Note: If at any time you turn on the system and it fails to connect, check to be sure the correct model memory is selected in the transmitter. Please note that the DX5e and Aircraft Modules do not have ModelMatch.

Failsafe

Your AR6400 features failsafe programming. Failsafe prevents accidental motor operation before the system connects and, in the unlikely event of signal loss, Failsafe drives the throttle to a preset (off) position and all other servos to their neutral positions.

While your DSM equipped 2.4GHz system is intuitive to operate, functioning nearly identically to 72MHz systems, following are a few common questions from customers.

1. Q: Sometimes the system takes longer to connect and sometimes it doesn't connect at all?

A: In order for the system to connect (after the receiver is bound) the receiver must receive a large number of consecutive uninterrupted perfect packets from the transmitter. This process is purposely critical of the environment ensuring that it's safe to fly when the system does connect. If the transmitter is too close to the receiver (less than 4 ft) or if the transmitter is located near metal objects (metal TX case, the bed of a truck, the top of a metal work bench, etc.) connection will take longer and in some cases connection will not occur as the system is receiving reflected 2.4GHz energy from itself and is interpreting this as unfriendly noise. Moving the system away from metal objects or moving the transmitter away from the receiver and powering the system again will cause a connection to occur. This only happens during the initial connection. Once connected the system is locked-in and should a loss of signal occur (failsafe) the system connects immediately (4ms) when signal is regained.

2. Q: Sometimes my receiver loses its bind and won't connect requiring rebinding. What happens if the bind is lost in flight?

A: The receiver will never lose its bind unless it's instructed to. It's important to understand that during the binding process the receiver not only learns the GUID (code) of the transmitter but the transmitter learns and stores the type of receiver that it's bound to. If the transmitter is placed into bind mode, the transmitter looks for the binding protocol signal from a receiver. If no signal is present, the transmitter no longer has the correct information to connect to a specific receiver and in essence the transmitter has been "unbound" from the receiver. We've had several DX7 customers that use transmitter stands or trays that unknowingly depress the bind button and the system is then turned on losing the necessary information to allow the connection to take place. We've also had DX7 customers that didn't fully understand the range test process and pushed the bind button before turning on the transmitter also causing the system to "lose its bind."

Warranty Period

Exclusive Warranty- Horizon Hobby, Inc., (Horizon) warranties that the Products purchased (the "Product") will be free from defects in materials and workmanship for a period of 1 year from the date of purchase by the Purchaser.

Limited Warranty

(a) This warranty is limited to the original Purchaser ("Purchaser") and is not transferable. REPAIR OR REPLACEMENT AS PROVIDED UNDER THIS WARRANTY IS THE EXCLUSIVE REMEDY OF THE PURCHASER. This warranty covers only those Products purchased from an authorized Horizon dealer. Third party transactions are not covered by this warranty. Proof of purchase is required for warranty claims. Further, Horizon reserves the right to change or modify this warranty without notice and disclaims all other warranties, express or implied.

(b) Limitations- HORIZON MAKES NO WARRANTY OR REPRESENTATION, EXPRESS OR IMPLIED, ABOUT NON-INFRINGEMENT, MERCHANTABILITY OR FITNESS FOR A PARTICULAR PURPOSE OF THE PRODUCT. THE PURCHASER ACKNOWLEDGES THAT THEY ALONE HAVE DETERMINED THAT THE PRODUCT WILL SUITABLY MEET THE REQUIREMENTS OF THE PURCHASER'S INTENDED USE.

(c) Purchaser Remedy- Horizon's sole obligation hereunder shall be that Horizon will, at its option, (i) repair or (ii) replace, any Product determined by Horizon to be defective. In the event of a defect, these are the Purchaser's exclusive remedies. Horizon reserves the right to inspect any and all equipment involved in a warranty claim. Repair or replacement decisions are at the sole discretion of Horizon. This warranty does not cover cosmetic damage or damage due to acts of God, accident, misuse, abuse, negligence, commercial use, or modification of or to any part of the Product. This warranty does not cover damage due to improper installation, operation, maintenance, or attempted repair by anyone other than Horizon. Return of any goods by Purchaser must be approved in writing by Horizon before shipment.

Damage Limits

HORIZON SHALL NOT BE LIABLE FOR SPECIAL, INDIRECT OR CONSEQUENTIAL DAMAGES, LOSS OF PROFITS OR PRODUCTION OR COMMERCIAL LOSS IN ANY WAY CONNECTED WITH THE PRODUCT, WHETHER SUCH CLAIM IS BASED IN CONTRACT, WARRANTY, NEGLIGENCE, OR STRICT LIABILITY. Further, in no event shall the liability of Horizon exceed the individual price of the Product on which liability is asserted. As Horizon has no control over use, setup, final assembly, modification or misuse, no liability shall be assumed nor accepted for any resulting damage or injury. By the act of use, setup or assembly, the user accepts all resulting liability.

If you as the Purchaser or user are not prepared to accept the liability associated with the use of this Product, you are advised to return this Product immediately in new and unused condition to the place of purchase.

Law: These Terms are governed by Illinois law (without regard to conflict of law principals).

Safety Precautions

This is a sophisticated hobby Product and not a toy. It must be operated with caution and common sense and requires some basic mechanical ability. Failure to operate this Product in a safe and responsible manner could result in injury or damage to the Product or other property. This Product is not intended for use by children without direct adult supervision. The Product manual contains instructions for safety, operation and maintenance. It is essential to read and follow all the instructions and warnings in the manual, prior to assembly, setup or use, in order to operate correctly and avoid damage or injury.

Questions, Assistance, and Repairs

Your local hobby store and/or place of purchase cannot provide warranty support or repair. Once assembly, setup or use of the Product has been started, you must contact Horizon directly. This will enable Horizon to better answer your questions and service you in the event that you may need any assistance. For questions or assistance, please direct your email to productsupport@horizonhobby.com, or call 877.504.0233 toll free to speak to the Product Support department.

Inspection or Repairs

If this Product needs to be inspected or repaired, please call for a Return Merchandise Authorization (RMA). Pack the Product securely using a shipping carton. Please note that original boxes may be included, but are not designed to withstand the rigors of shipping without additional protection. Ship via a carrier that provides tracking and insurance for lost or damaged parcels, as Horizon is not responsible for merchandise until it arrives and is accepted at our facility. A Service Repair Request is available at www.horizonhobby.com on the "Support" tab. If you do not have internet access, please include a letter with your complete name, street address, email address and phone number where you can be reached during business days, your RMA number, a list of the included items, method of payment for any non-warranty expenses and a brief summary of the problem. Your original sales receipt must also be included for warranty consideration. Be sure your name, address, and RMA number are clearly written on the outside of the shipping carton.

Warranty Inspection and Repairs

To receive warranty service, you must include your original sales receipt verifying the proof-of-purchase date. Provided warranty conditions have been met, your Product will be repaired or replaced free of charge. Repair or replacement decisions are at the sole discretion of Horizon Hobby.

Non-Warranty Repairs

Should your repair not be covered by warranty the repair will be completed and payment will be required without notification or estimate of the expense unless the expense exceeds 50% of the retail purchase cost. By

submitting the item for repair you are agreeing to payment of the repair without notification. Repair estimates are available upon request. You must include this request with your repair. Non-warranty repair estimates will be billed a minimum of ½ hour of labor. In addition you will be billed for return freight. Please advise us of your preferred method of payment. Horizon accepts money orders and cashiers checks, as well as Visa, MasterCard, American Express, and Discover cards. If you choose to pay by credit card, please include your credit card number and expiration date. Any repair left unpaid or unclaimed after 90 days will be considered abandoned and will be disposed of accordingly. Please note: non-warranty repair is only available on electronics and model engines.

Electronics and engines requiring inspection or repair should be shipped to the following address:

Horizon Service Center
4105 Fieldstone Road
Champaign, Illinois 61822 USA

All other Products requiring warranty inspection or repair should be shipped to the following address:

Horizon Product Support
4105 Fieldstone Road
Champaign, Illinois 61822 USA

Please call 877-504-0233 or e-mail us at productsupport@horizonhobby.com with any questions or concerns regarding this product or warranty.

European Union:

Electronics and engines requiring inspection or repair should be shipped to one of the following addresses:

Horizon Hobby UK
Units 1-4 Ployters Rd
Staple Tye, Harlow
Essex CM18 7NS
United Kingdom

Please call +44 (0) 1279 641 097 or email sales@horizonhobby.co.uk with any questions or concerns regarding this product or warranty.

Horizon Technischer Service
Hamburger Str. 10
25335 Elmshorn
Germany

Please call +49 4121 46199 66 or email service@horizonhobby.de with any questions or concerns regarding this product or warranty.

CE Compliance Information for the European Union

Declaration of Conformity

(in accordance with ISO/IEC 17050-1)

No. HH2009040201

Product(s): AR6400 Receiver
Item Number(s): SPMAR6400

The object of declaration described above is in conformity with the requirements of the specifications listed below, following the provisions of the European R&TTE directive 1999/5/EC:

EN 301 489-1, 301 489-17 General EMC requirements for Radio equipment

Signed for and on behalf of:
Horizon Hobby, Inc.
Champaign, IL USA
April 02, 2009

Steven A. Hall
Vice President
International Operations and Risk Management
Horizon Hobby, Inc.

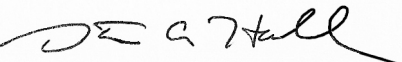

Instructions for Disposal of WEEE by Users in the European Union

This product must not be disposed of with other waste. Instead, it is the user's responsibility to dispose of their waste equipment by handing it over to a designated collection point for the recycling of waste electrical and electronic equipment. The separate collection and recycling of your waste equipment at the time of disposal will help to conserve natural resources and ensure that it is recycled in a manner that protects human health and the environment. For more information about where you can drop off your waste equipment for recycling, please contact your local city office, your household waste disposal service or where you purchased the product.

