

RTR
READY-TO-RUN

AVC[®] U.S. Pat. No. 9,320,977

RR5[™]SCT



**Battery and Charger
Not Included**

**INSTRUCTION MANUAL
BEDIENUNGSANLEITUNG
MANUEL D'UTILISATION
MANUALE DI ISTRUZIONI**



Before operating this vehicle, please read all printed materials thoroughly.
Horizon Hobby is not responsible for inadvertent errors in this manual.

NOTICE

All instructions, warranties and other collateral documents are subject to change at the sole discretion of Horizon Hobby, LLC. For up-to-date product literature, visit horizonhobby.com and click on the support tab for this product.

MEANING OF SPECIAL LANGUAGE

The following terms are used throughout the product literature to indicate various levels of potential harm when operating this product:

WARNING: Procedures, which if not properly followed, create the probability of property damage, collateral damage, and serious injury OR create a high probability of superficial injury.

CAUTION: Procedures, which if not properly followed, create the probability of physical property damage AND a possibility of serious injury.

NOTICE: Procedures, which if not properly followed, create a possibility of physical property damage AND a little or no possibility of injury.

 **WARNING:** Read the ENTIRE instruction manual to become familiar with the features of the product before operating. Failure to operate the product correctly can result in damage to the product, personal property and cause serious injury.

This is a sophisticated hobby product. It must be operated with caution and common sense and requires some basic mechanical ability. Failure to operate this Product in a safe and responsible manner could result in injury or damage to the product or other property. This product is not intended for use by children without direct adult supervision. Do not use with incompatible components or alter this product in any way outside of the instructions provided by Horizon Hobby, LLC. This manual contains instructions for safety, operation and maintenance. It is essential to read and follow all the instructions and warnings in the manual, prior to assembly, setup or use, in order to operate correctly and avoid damage or serious injury.

 **WARNING AGAINST COUNTERFEIT PRODUCTS** Always purchase from a Horizon Hobby, LLC authorized dealer to ensure authentic high-quality Spektrum product. Horizon Hobby, LLC disclaims all support and warranty with regards, but not limited to, compatibility and performance of counterfeit products or products claiming compatibility with DSM or Spektrum.

Age Recommendation: Not for children under 14 years. This is not a toy.

SAFETY PRECAUTIONS AND WARNINGS

As the user of this product, you are solely responsible for operating in a manner that does not endanger yourself and others or result in damage to the product or property of others.

This model is controlled by a radio signal subject to interference from many sources outside your control. This interference can cause momentary loss of control, so it is advisable to always keep a safe distance in all directions around your model as this margin will help avoid collisions or injury.

- Never operate your model with low transmitter batteries.
- Always operate your model in open spaces away from full-size vehicles, traffic and people.
- Never operate the model in the street or in populated areas for any reason.
- Carefully follow the directions and warnings for this and any optional support equipment (chargers, rechargeable battery packs, etc.) you use.
- Keep all chemicals, small parts and anything electrical out of the reach of children.

- Never lick or place any portion of the model in your mouth as it could cause serious injury or even death.
- Exercise caution when using tools and sharp instruments.
- Take care during maintenance as some parts may have sharp edges.
- Immediately after using your model, do NOT touch equipment such as the motor, electronic speed control and battery, because they generate high temperatures. You may burn yourself seriously touching them.
- Do not put fingers or any objects inside rotating and moving parts, as this may cause damage or serious injury.
- Always turn on your transmitter before you turn on the receiver in the car. Always turn off the receiver before turning your transmitter off.
- Keep the wheels of the model off the ground when checking the operation of the radio equipment.

TABLE OF CONTENTS

REGISTER YOUR LOSI PRODUCT ONLINE	2	DYNAMITE® FUZE™ 60A SPORT BRUSHLESS ESC (DYN2405)	6
BOX CONTENTS	3	SPECIFICATIONS	6
COMPONENTS	3	ESC LED STATUS	6
WATER-RESISTANT VEHICLE WITH WATERPROOF ELECTRONICS	3	MOTOR TO ESC CONNECTION	6
GENERAL PRECAUTIONS	3	ESC CALIBRATION PROCEDURE	6
WET CONDITIONS MAINTENANCE	3	ESC FUNCTIONS AND MODES	6
QUICK START	3	ESC PROGRAMMING PROCEDURE	7
CHARGING THE BATTERY	3	DESCRIPTIONS	7
INSTALLING THE BATTERY	4	DYNAMITE® FUZE™ SPORT 3300KV BRUSHLESS MOTOR (DYN1495)	8
SPEKTRUM DX2E ACTIVE RADIO SYSTEM	4	PRECAUTIONS	8
INSTALLING THE TRANSMITTER BATTERIES	4	GEARING	8
SRS6000 AVC TECHNOLOGY RECEIVER	4	CHANGING THE PINION GEAR/GEAR RATIO	8
AUX CHANNELS	4	SETTING THE GEAR MESH	8
BINDING AND CALIBRATING THE RECEIVER	5	TROUBLESHOOTING GUIDE	8
DISABLING THE STABILITY ASSIST FUNCTION	5	LIMITED WARRANTY	8-9
DRIVING PRECAUTIONS	5	WARRANTY AND SERVICE CONTACT INFORMATION	9
POWERING ON THE VEHICLE	5	FCC STATEMENT	9
BEFORE RUNNING YOUR VEHICLE	5	IC INFORMATION	9
AVC® SENSITIVITY	5	COMPLIANCE INFORMATION FOR THE EUROPEAN UNION	9
RUN TIME	6	REPLACEMENT PARTS	35
TO IMPROVE RUN TIMES	6	RECOMMENDED PARTS	35
PERFORMING A CONTROL DIRECTION TEST	6	OPTIONAL PARTS	35
CHANGING THE TRAVEL ADJUST SETTINGS	6	EXPLODED VIEW	36-39

REGISTER YOUR LOSI PRODUCT ONLINE

Register your vehicle now and be the first to find out about the latest option parts, product updates and more. Click on the Support tab at WWW.LOSI.COM and follow the product registration link to stay connected.

BOX CONTENTS

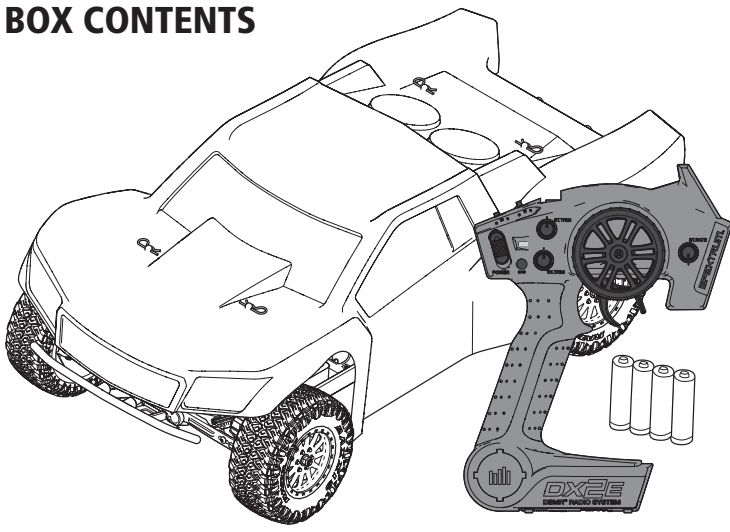

COMPONENTS

- Losi® 225 SCT RTR, AVC®: 1/10-Scale 2WD Short Course Truck
- Spektrum™ DX2E Active™, 2.4GHz Transmitter (SPM2335)
- Spektrum™ 6-Channel DSMR® AVC Surface Receiver (SPMSRS6000)
- Spektrum™ 6KG Waterproof Servo (SPMS606)
- Dynamite® Fuze™ 60A Sport Brushless ESC (DYN2405)
- Dynamite® Fuze™ Sport Brushless Motor 3300Kv (DYN1495)
- 4 AA batteries (for transmitter)

WATER-RESISTANT VEHICLE WITH WATERPROOF ELECTRONICS

Your new Horizon Hobby vehicle has been designed and built with a combination of waterproof and water-resistant components to allow you to operate the product in many “wet conditions,” including puddles, creeks, wet grass, snow and even rain.

While the entire vehicle is highly water-resistant, it is not completely waterproof and your vehicle should NOT be treated like a submarine. The various electronic components used in the vehicle, such as the Electronic Speed Control (ESC), servo(s) and receiver are waterproof, however, most of the mechanical components are water-resistant and should not be submerged.

Metal parts, including the bearings, hinge pins, screws and nuts, as well as the contacts in the electrical cables, will be susceptible to corrosion if additional maintenance is not performed after running in wet conditions. To maximize the long-term performance of your vehicle and to keep the warranty intact, the procedures described in the “Wet Conditions Maintenance” section below must be performed regularly if you choose to run in wet conditions. If you are not willing to perform the additional care and maintenance required, then you should not operate the vehicle in those conditions.

CAUTION: Failure to exercise caution while using this product and complying with the following precautions could result in product malfunction and/or void the warranty.

GENERAL PRECAUTIONS

- Read through the wet conditions maintenance procedures and make sure that you have all the tools you will need to properly maintain your vehicle.
- Not all batteries can be used in wet conditions. Consult the battery manufacturer before use. Caution should be taken when using Li-Po batteries in wet conditions.
- Most transmitters are not water-resistant. Consult your transmitter’s manual or the manufacturer before operation.
- Never operate your transmitter or vehicle where lightning may be present.
- Do not operate your vehicle where it could come in contact with salt water (ocean water or water on salt-covered roads), contaminated or polluted water. Salt water is very conductive and highly corrosive, so use caution.
- Even minimal water contact can reduce the life of your motor if it has not been certified as water-resistant or waterproof. If the motor becomes excessively wet, apply very light throttle until the water is mostly removed from the motor. Running a wet motor at high speeds may rapidly damage the motor.
- Driving in wet conditions can reduce the life of the motor. The additional resistance of operating in water causes excess strain. Alter the gear ratio by using a smaller pinion or larger spur gear. This will increase torque (and motor life) when running in mud, deeper puddles, or any wet conditions that will increase the load on the motor for an extended period of time.

WET CONDITIONS MAINTENANCE

- Drain any water that has collected in the tires by spinning them at high speed. With the body removed, place the vehicle upside down and pull full throttle for a few short bursts until the water has been removed.

CAUTION: Always keep hands, fingers, tools and any loose or hanging objects away from rotating parts when performing the above drying technique.

- Remove the battery pack(s) and dry the contacts. If you have an air compressor or a can of compressed air, blow out any water that may be inside the recessed connector housing.
- Remove the tires/wheels from the vehicle and gently rinse the mud and dirt off with a garden hose. Avoid rinsing the bearings and transmission.

NOTICE: Never use a pressure washer to clean your vehicle.

- Use an air compressor or a can of compressed air to dry the vehicle and help remove any water that may have gotten into small crevices or corners.
- Spray the bearings, drive train, fasteners and other metal parts with a water-displacing light oil. Do not spray the motor.
- Let the vehicle air dry before you store it. Water (and oil) may continue to drip for a few hours.
- Increase the frequency of disassembly, inspection and lubrication of the following:
 - Front and rear axle hub assembly bearings.
 - All transmission cases, gears and differentials.
 - Motor—clean with an aerosol motor cleaner and re-oil the bushings with lightweight motor oil.

QUICK START

Please read the entire manual to gain a full understanding of the 225 RTR vehicle, fine-tuning the setup and performing maintenance.

1. Read the safety precautions found in this manual.
2. Charge a battery for the vehicle. Refer to the included charging warnings and instructions for battery charging information.
3. Install the AA batteries in the transmitter. Only use alkaline or rechargeable batteries.
4. Install the fully charged battery in the vehicle.
5. Power ON the transmitter and then the vehicle. Wait 5 seconds for the ESC to initialize. Always power the transmitter ON before the vehicle and power it OFF after the vehicle has been powered OFF.
6. Check the steering and throttle control directions. Verify that the servos are moving in the correct direction.
7. Drive your vehicle.
8. Power OFF the vehicle and then the transmitter.
9. Unplug the battery and remove it from the vehicle.
10. Perform any necessary maintenance.

CHARGING THE BATTERY

Choose a battery designed to work with the Dynamite® Fuze™ Sport Brushless ESC: 60A. We recommend the Dynamite® 7.4 5000mAh 2S 50C LiPo: Hardcase with EC3™ connector (DYNB33802EC) or Dynamite 11.1 5000mAh 3S 50C LiPo Hardcase with EC3 connector

(DYNB3803EC). Choose a charger designed to charge 2S and/or 3S Li-Po batteries. We recommend the Dynamite® Prophet™ Sport Li-Po 35W AC Battery Charger (DYN2005CA). Refer to your battery and charger manuals for usage, safety, and charging information.

INSTALLING THE BATTERY

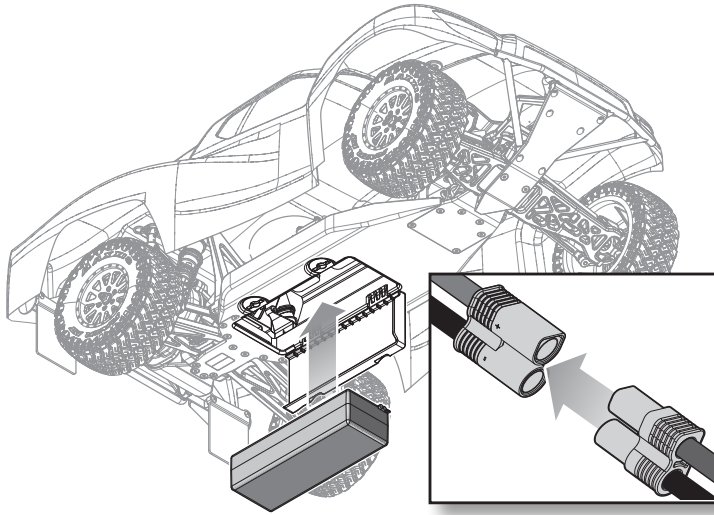

1. Ensure the ESC is powered OFF.
2. Rotate the battery hatch lock to align the flat section with the edge of the battery hatch.
3. Open the battery hatch.
4. Install the fully charged battery in the vehicle.

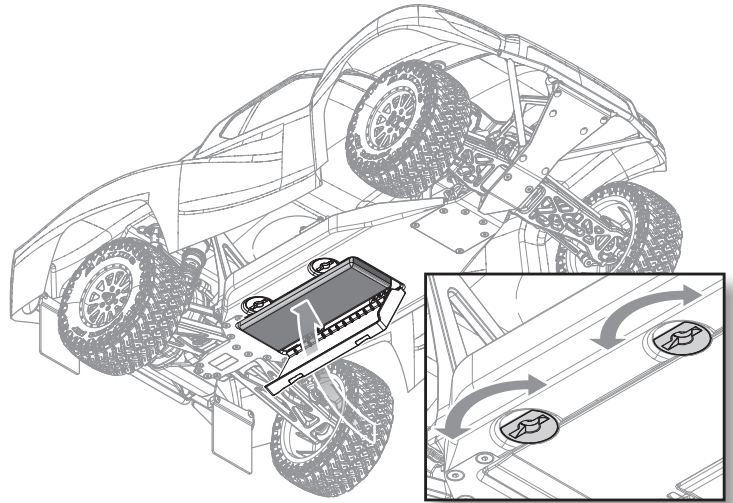

5. Close the battery hatch and rotate the lock fully to secure the hatch.
6. Connect the battery to the ESC noting the correct polarity.
7. Power ON the transmitter, then the vehicle.

SPEKTRUM DX2E ACTIVE RADIO SYSTEM

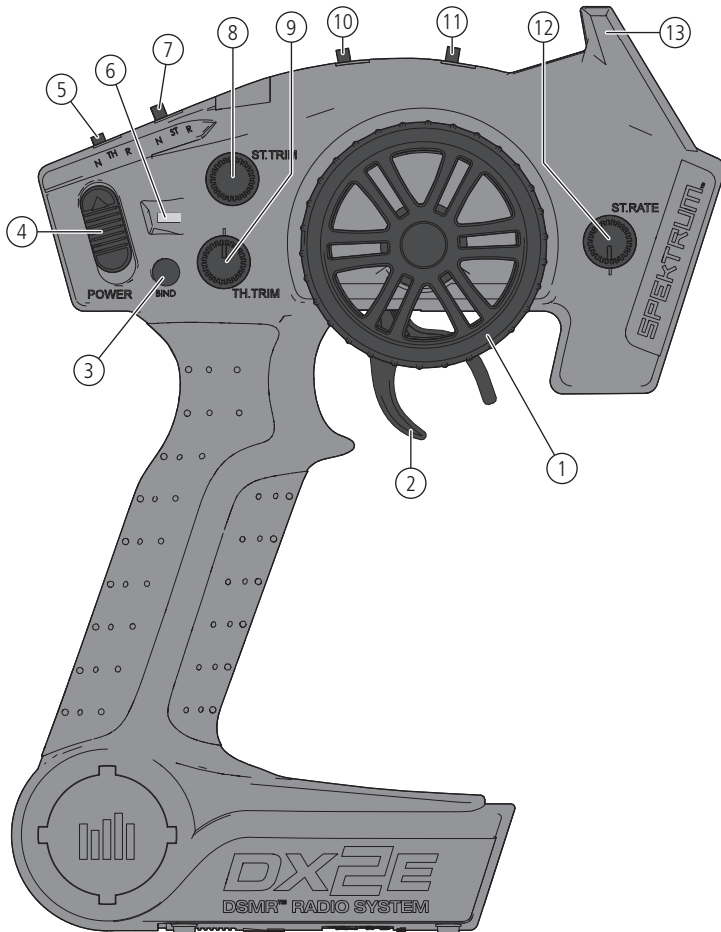

1. **Steering Wheel** Controls direction (left/right) of the model
2. **Throttle Trigger** Controls speed and direction (forward/brake/reverse) of the model
3. **BIND Button** Puts the transmitter into Bind Mode
4. **ON/OFF Switch** Turns the power ON/OFF for the transmitter
5. **TH.REV** Reverses function of the speed control when pulled back or pushed forward
6. **Indicator Lights**
 - Solid green light—indicates adequate battery power
 - Flashing green light—indicates the battery voltage is critically low. Replace batteries
7. **ST. REV** Reverses the function of the steering when the wheels is turned left or right
8. **ST Trim** Adjusts the steering center point
9. **TH Trim** Adjusts the throttle neutral point
10. **TH Limiter** Limits throttle output to 50, 70 or 100%.
11. **3-Position Switch** Used to control a third channel and is preset at -100%/Neutral/100%
12. **ST Rate** Adjusts the sensitivity of AVC technology
13. **Antenna** Transmits the signal to the model

INSTALLING THE TRANSMITTER BATTERIES

1. Push in the battery cover a small amount to release the retaining tab, then remove the cover.
2. Install 4 AA batteries, taking care to align the battery polarity to the diagram in the transmitter's battery case.
3. Carefully reinstall the battery cover by aligning the tabs with the slots on the transmitter.

For more information on the transmitter, go to www.horizonhobby.com and click on the support tab for the Spektrum DX2E to download the instruction manual.

CAUTION: Never remove the transmitter batteries while the model is powered ON. Loss of model control, damage, or injury may occur.

CAUTION: If using rechargeable batteries, charge only rechargeable batteries. Charging non-rechargeable batteries may cause the batteries to burst, resulting in injury to persons and/or damage to property.

CAUTION: Risk of explosion if battery is replaced by an incorrect type. Dispose of used batteries according to national regulations.

SRS6000 AVC TECHNOLOGY RECEIVER

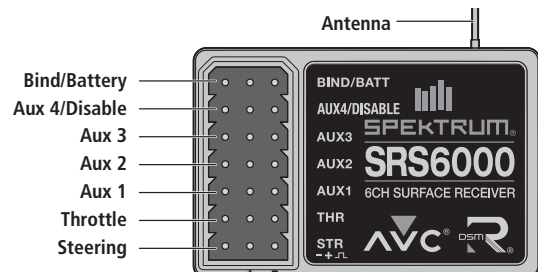

AUX CHANNELS

The Aux channels can operate as additional servo channels, or as a power supply for a personal transponder.

If AVC is active, only 4 channels; Steering, Throttle, AUX3 and AUX4 are operational. The remaining Aux channels can be used to power a personal transponder or lights.

If AVC is disabled (see **DISABLING THE STABILITY ASSIST FUNCTION**), all 6 channels including the Aux channels can operate as servo channels.

BINDING AND CALIBRATING THE RECEIVER

In order to operate, the receiver must be bound to the transmitter. Binding is the process of programming the receiver to recognize the GUID (Globally Unique Identifier) code of a single specific transmitter. When a receiver is bound to a transmitter/model memory, the receiver will only respond to that specific transmitter/model memory. **The receiver and transmitter are bound at the factory and ready for use.** If your system becomes unbound or if you select a different transmitter, follow the steps below.

You must calibrate the receiver each time it is placed in bind mode.

IMPORTANT: The following sequence of steps must be followed in order for AVC technology to function properly.

1. Insert the Bind Plug in the BIND port on the receiver.
2. Power on the receiver. The orange LED flashes, indicating the receiver is in bind mode.
3. Center the ST TRIM and TH TRIM on the transmitter.
4. Put your transmitter in bind mode by powering on transmitter while holding down bind button.
5. The bind process is complete when the orange LED on the receiver is solid.
6. Pull the transmitter trigger to Full Throttle.
7. Push the transmitter trigger to Full Brake, then return the trigger to center.

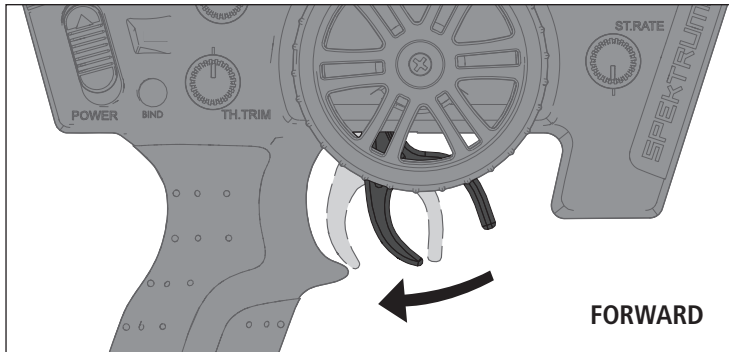

8. Turn the transmitter steering wheel to Full Right.
9. Turn the transmitter steering wheel to Full Left, then return the steering wheel to center. The orange LED flashes once.
10. Remove the bind plug once the calibration and binding process is complete.
11. Power off the transmitter.

IMPORTANT: You must rebind the transmitter and receiver if you:

- Change the servo reverse after binding
 - Change the travel after binding
 - Want to use the receiver with a different model memory
- If you change the servo reversing or travel adjust after binding, AVC will not work properly.

DISABLING THE STABILITY ASSIST FUNCTION

If you participate in organized racing, you may be required to turn AVC® technology off. To turn off AVC technology, insert a second Bind Plug in the Disable port before binding and calibrating.

IMPORTANT: You must calibrate the receiver each time it is placed in bind mode. To activate AVC, see the steps in BINDING AND CALIBRATING THE RECEIVER.

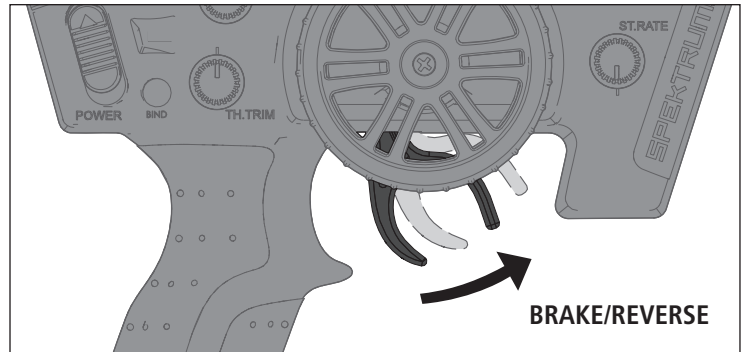

DRIVING PRECAUTIONS

- Maintain sight of the vehicle at all times.
- Routinely inspect the vehicle for loose wheel hardware.
- Routinely inspect the steering assembly for any loose hardware. Driving the vehicle off-road can cause fasteners to loosen over time.
- Do not drive the vehicle in tall grass. Doing so can damage the vehicle or electronics.
- Stop driving the vehicle when you notice a lack of power. Driving the vehicle when the battery is discharged can cause the receiver to power off. If the receiver loses power, you will lose control of the vehicle. Damage due to an over-discharged Li-Po battery is not covered under warranty.

CAUTION: Do not discharge a Li-Po battery below 3V per cell. Batteries discharged to a voltage lower than the lowest approved voltage may become damaged, resulting in loss of performance and potential fire when batteries are charged.

- Do not apply forward or reverse throttle if the vehicle is stuck. Applying throttle in this instance can damage the motor or ESC.
- After driving the vehicle, allow the electronics to cool before driving the vehicle again.

IMPORTANT: Keep wires away from all moving parts.

BEFORE RUNNING YOUR VEHICLE

1. Check for free suspension movement. All suspension arms and steering components should move freely. Any binds will cause the vehicle to handle poorly.

Tip: To increase the ride height and ground clearance of your vehicle, install the included shock spacers.

2. Charge a battery pack. Always charge the battery pack as per the battery and/or charger manufacturers' instructions.
3. Set the transmitter steering trim. Follow the instructions to set the steering trim/subtrim so that the vehicle drives straight with no input to the steering.
4. Perform a Control Direction Test.

POWERING ON THE VEHICLE

1. Center the ST TRIM and TH TRIM dials on the transmitter.
2. Power on the transmitter.
3. Install a fully charged battery pack per the *Installing the Battery* section.
4. Power on the ESC.

IMPORTANT: The vehicle **MUST** remain on a flat, level surface and motionless for at least 5 seconds.

AVC® SENSITIVITY

The ST RATE dial adjusts the sensitivity, or stability, value in the receiver. If you increase the sensitivity, the AVC® system becomes more sensitive to the vehicle drifting left or right. You would use maximum sensitivity during high speed driving or drag racing, when you want the vehicle to stay in a straight line.

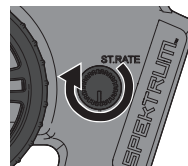

Turn the ST RATE knob counter-clockwise to reduce the sensitivity.
Turn the ST RATE knob clockwise to increase the sensitivity.

IMPORTANT: The ST RATE knob will only adjust the sensitivity when the transmitter is bound to a DSMR® receiver. When the transmitter is bound to a DSM®, DSM2® or DSM Marine receiver, the ST RATE knob controls the steering dual rate.

RUN TIME

The largest factor in run time is the capacity of the battery pack. A larger mAh rating increases the amount of run time experienced.

The condition of a battery pack is also an important factor in both run time and speed. The battery connectors may become hot during driving. Batteries will lose performance and capacity over time.

Driving the vehicle from a stop to full speed repeatedly will damage the batteries and electronics over time. Sudden acceleration will also lead to shorter run times.

TO IMPROVE RUN TIMES

- Keep your vehicle clean and well maintained.
- Allow more airflow to the ESC and motor.
- Change the gearing to a lower ratio. A lower ratio decreases the operating temperature of the electronics. Use a smaller pinion gear or larger spur gear to lower the gear ratio.
- Use a battery pack with a higher mAh rating.
- Use the optimum charger to charge battery packs (Visit your local hobby dealer for more information).

PERFORMING A CONTROL DIRECTION TEST

Perform a control test with the vehicle wheels off the ground. If the wheels rotate after the vehicle is powered ON, adjust the TH Trim knob until they stop. To make the wheels move forward, pull the trigger. To reverse them, wait for the wheels to stop, then push the trigger. When moving forward, the wheels should maintain a straight line without any steering wheel input. If not, adjust the ST Trim knob, so the wheels maintain a straight line without having to turn the steering wheel.

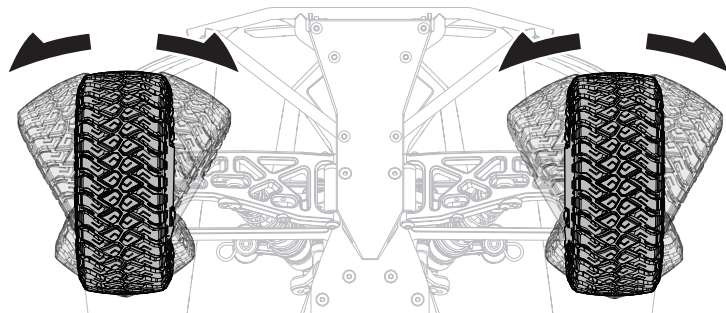

CHANGING THE TRAVEL ADJUST SETTINGS

Set the travel adjust settings with all four vehicle wheels off the ground. The throttle end point and brake end point adjustments will cause the wheels to spin at full speed. Have an assistant safely hold the vehicle securely while adjusting these settings.



CAUTION: Keep hands, hair and all loose clothing away from any moving parts, especially the wheels, while setting the travel adjust end points. Serious injury may result.

1. Hold the trigger in the full brake position and turn the steering wheel to Full Right while powering on the transmitter. The LED flashes rapidly, indicating the programming mode is active.
2. Throttle End Point: Continue holding full throttle. Turn the TH TRIM knob to adjust the full throttle end point.
3. Brake End Point: Hold the trigger in the full brake position. Turn the TH TRIM knob to adjust the full brake end point. Return the trigger to the center position.
4. Left Steering End Point: Hold the steering wheel in the full left position. Turn the ST TRIM knob to adjust the left end point.
5. Right Steering End Point: Hold the steering wheel in the full right position. Turn the ST TRIM knob to adjust the right end point. Return the steering wheel to the center position.
6. Power off the transmitter to save the travel adjust settings.
The minimum Travel is 75%, and the Maximum travel is 150%.

IMPORTANT: If the travel is changed on the DX2E, you must rebind and calibrate the SRS6000.

DYNAMITE® FUZE™ 60A SPORT BRUSHLESS ESC (DYSN2405)

SPECIFICATIONS

Type	Sensorless
Constant/Peak	60A/90A
Resistance	1.7mΩ
Function	Forward/Brake-Forward/Brake Reverse
Operation	Proportional forward, proportional reverse with braking delay
Input Voltage	2-3S LiPo, 6-8 Cell NiMH
BEC Output	6V/2A
Overload Protection	Thermal
Dimensions (LxWxH)	40mm x 32mm x 19mm
Weight	51 g

ESC LED STATUS

- In the neutral position, no LEDs are lit.
- The red LED lights when the car is moving forward, reversing or braking (sensorless motor).
- The green LED lights when the car is moving forward, reversing or braking (sensored motor).
- The red LED flashes if the battery voltage has reached LVC.
- The red and green LEDs light alternately, indicating the ESC overheating protection is enabled.
- The red LED lights if the receiver signal is incorrect or missing.

MOTOR TO ESC CONNECTION

1. Connect the blue motor lead to the blue ESC lead.
2. Connect the yellow motor lead to the yellow ESC lead.
3. Connect the orange motor lead to the orange ESC lead.

Tip: If the motor turns in the wrong direction, reverse the connection of any 2 motor wires.

NOTICE: Always disconnect the battery from the ESC when you have finished operating your vehicle. The ESC's switch only controls power to the receiver and servos. The ESC will continue to draw current when connected to the battery, resulting in possible damage to the battery through over discharge.

ESC CALIBRATION PROCEDURE

Ensure proper ESC function by calibrating the ESC to your transmitter inputs.

1. Power OFF the ESC.
2. Ensure your transmitter is powered ON, the throttle is not reversed, the throttle trim is neutral and the throttle travel range is at 100%. Disable any special functions such as ABS, etc.
3. Press the SET button while powering ON the ESC. Release the button as soon as the red LED starts to flash and the motor emits a beep.
4. Calibrate the throttle points by pressing the SET button once after each step.
 - **Set Neutral:** leave the throttle at rest, untouched and press the SET button (1 green flash; 1 motor beep)
 - **Set Full Throttle:** pull the throttle fully back, then press the SET button (2 green flashes; 2 motor beeps)
 - **Set Full Brake/Reverse:** push the throttle fully forward, then press the SET button (3 green flashes; 3 motor beeps)

NOTICE: The motor will NOT run during the calibration procedure.

5. Power off the ESC. The ESC is calibrated and ready to run.

ESC FUNCTIONS AND MODES

The ESC includes programming options so you can adjust the way your vehicle performs. Refer to the included settings table to adjust the ESC for your driving conditions.

ESC PROGRAMMING PROCEDURE

Programming is accomplished using the SET button on the ON/OFF switch.

1. Connect a fully charged battery to the ESC.
2. Power ON the ESC using the ESC switch.
3. Press and hold the SET button for 3 seconds until the green LED flashes, then release the SET button.
4. Press the SET button once until the green LED blinks once in sequence, indicating programmable value 1 is currently selected.

Tip: Pressing the setup button once more moves to programmable value 2, etc. until the desired programmable value is reached. The system continues in a 'loop'.

5. When at the desired menu item, hold the SET button for 3 seconds until the red LED blinks.

Tip: The RED flashing sequence indicates the actual setting; for example one flash indicates value 1 is selected, two flashes indicates value 2, etc.
6. Press the setup button in sequence to select the desired programmable value. The system continues in a "loop."
7. Save the setting by holding the SET button for 3 seconds. The motor beeps once.
8. Power OFF the ESC then immediately power it ON. The setting change is stored.

Tip: Only one setting can be stored/saved at a time.

PROGRAMMABLE ITEMS Basic Items	PROGRAMMABLE VALUE			
	1	2	3	4
1 Running Mode	Forward w/ brake	Forward/Reverse w/ brake		
2 Drag Brake Force	0%	5%	10%	20%
3 Low Voltage Cutoff	non-protection	3.0V/Cell	3.2V/Cell	3.4V/Cell
4 Start Mode	Level 1	Level 2	Level 3	Level 4
5 Max Brake Force	25%	50%	75%	100%
6 Punch	Level 1	Level 2	Level 3	Level 4

■ Default Settings

DESCRIPTIONS

1. Running Mode

- *Forward Only with Brake*
Intended for competition use, this mode allows only forward and brake controls.
- *Forward/Reverse with Brake*
This mode is the basic all-around mode, allowing forward, reverse and brake controls. To engage reverse while moving forward, apply the brake until the vehicle has come to a complete stop, release brake, then apply the brake again. While braking or in reverse, engaging the throttle will result in the vehicle immediately accelerating forward.

2. Drag Brake Force

Adjusts the amount of brake automatically applied when the throttle is returned to the neutral position. This simulates the engine braking effect of a full-scale vehicle, allowing improved turn-in and your vehicle's general response to controls.

3. Low Voltage Cutoff

This function helps to prevent battery over-discharge. The ESC continuously monitors the battery's voltage. If the voltage falls below the voltage threshold for 2 seconds, the output power shuts off and the red LED flashes twice repeatedly.

The cutoff threshold calculation is based on individual Li-Po cell voltage. For Ni-MH batteries, if the voltage battery pack is higher than 9.0V, it will be treated as a 3-cell Li-Po battery pack; if it is lower than 9.0V, it will be treated as a 2-cell Li-Po battery pack. Example: for a 8.0V Ni-MH battery pack used with a 2.6V/cell threshold, it will be treated as a 2-cell Li-Po battery pack and the low-voltage cut-off threshold will be 5.2V (2.6 x 2=5.2).

4. Start Mode

Sets the initial throttle punch when the car accelerates. Level 1 gives a very soft initial acceleration and Level 4 gives a stronger initial acceleration.

5. Max Brake Force

Adjusts the maximum braking force. A higher value provides stronger braking, but can also cause the wheels to lock, resulting in loss of control of the car.

6. Punch

Select from start mode Level 1 (Soft) to Level 9 (Very aggressive). If you choose Levels 7–9, use a high quality battery pack with powerful discharge ability. Without a high quality battery pack, the modes will not give a bursting start effect. If the motor does not run smoothly (i.e., trembling), choose a better battery or increase the gear rate.

DYNAMITE® FUZE™ SPORT 3300KV BRUSHLESS MOTOR (DYNS1495)

PRECAUTIONS

- Never touch moving parts.
- Never disassemble while the batteries are installed.
- Always let parts cool before touching.

GEARING

The vehicle is equipped with optimal gearing for 3S batteries. When using 2S batteries, Use the stock gear or change it to 23T 48P to optimize speed, power and efficiency.

Installing a pinion gear with fewer teeth or a spur gear with more teeth will increase torque and reduce top speed. Likewise, a pinion gear with more teeth or a spur gear with fewer teeth will reduce torque and increase top speed. Take care when installing larger pinion gears as this can "overgear" the vehicle, resulting in an overheated motor and ESC. When testing different gearing options, pay close attention to the temperature of the motor and speed control to ensure you are operating within the correct temperature range. If the motor is too hot, switch to a lower pinion gear and/or higher spur gear combination.

CAUTION: Do not touch the ESC or motor after use or personal injury may result. Do not allow the ESC or motor to exceed 160°F (71°C). A temperature gun (recommended DYNF1055) can be used to safely monitor the temperature before handling.

CHANGING THE PINION GEAR/GEAR RATIO

1. Remove the screws holding the gear cover in place.
2. Loosen the set screw and remove the installed pinion gear.
3. Loosen the motor screws and slide the motor back.
4. Place the new pinion on the end of the motor shaft so the set screw is located over the flat on the shaft.
5. Position it so the teeth line up with the spur gear and secure the pinion by tightening the set screw.
6. Set the gear mesh.

SETTING THE GEAR MESH

The gear mesh has already been set at the factory. Setting it is only necessary when changing motors or gears.

Proper gear mesh (how gear teeth meet) is important to the performance of the vehicle. When the gear mesh is too loose, the spur gear could be damaged by the pinion gear of the motor. If the mesh is too tight, speed could be limited and the motor and ESC will overheat.

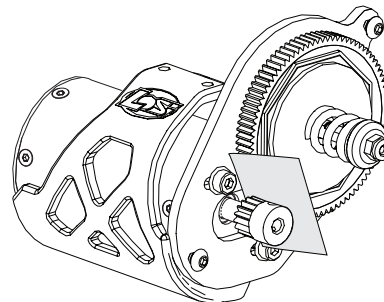

1. Loosen the motor screws and slide the motor back.
2. Put a small piece of paper between the pinion and spur gears.
3. Push the gears together while tightening the motor screws.
4. Remove the paper. Check the mesh at 3–5 different locations around the spur gear for a small amount of movement.
5. Install gear cover.

NOTICE: For a 3S Li-Po battery, use the included 18T pinion gear. For a 2S Li-Po battery, we recommend installing the optional 23T pinion gear (LOS4123). For speed runs, use an optional 22T pinion (LOS4122) with a 3S Li-Po battery to reach speeds exceeding 50MPH.

NOTICE: Gearing above 18T for a 3S Li-Po battery, or 23T for a 2S Li-Po battery may cause excessive motor and ESC temperatures, which could result in damage. Monitor temperatures regularly. Do NOT exceed 160°F (71°C) for the ESC. Do NOT exceed 180°F (82°C) for the motor.

TROUBLESHOOTING GUIDE

PROBLEM	POSSIBLE CAUSE	SOLUTION
Vehicle does not operate	Battery not charged or plugged in	Charge battery/plug in
	ESC switch not "ON"	Turn on ESC switch
	Transmitter not "ON" or low battery	Turn on/replace batteries
Motor runs but wheels do not rotate	Pinion not meshing with spur gear	Adjust pinion/spur mesh
	Pinion spinning on motor shaft	Tighten pinion gear setscrew on motor shaft flat spot
	Transmission gears stripped	Replace transmission gears
	Drive pin broken	Check and replace drive pin
Steering does not work	Servo plug not in receiver properly	Make sure the steering servo plug is connected to the receiver steering channel, noting proper polarity
	Servo gears or motor damaged	Replace or repair servo
Will not turn one direction	Servo gears damaged	Replace or repair servo
Motor does not run	Motor wire solder joint is damaged	Resolder the motor wire with the proper equipment
	Motor wire broken	Repair or replace as needed
	ESC damaged	Contact Horizon Hobby Product Support
ESC gets hot	Motor over-g geared	Use smaller pinion or larger spur gear
	Driveline bound up	Check wheels and transmission for binding
Poor run time and/or sluggish acceleration	Battery pack not fully charged	Recharge battery
	Charger not allowing full charge	Try another charger
	Driveline bound up	Check wheels, transmission for binding
Poor range and/or glitching	Transmitter batteries low	Check and replace
	Vehicle battery low	Recharge battery
	Loose plugs or wires	Check all wire connections and plugs

LIMITED WARRANTY

What this Warranty Covers

Horizon Hobby, LLC, (Horizon) warrants to the original purchaser that the product purchased (the "Product") will be free from defects in materials and workmanship at the date of purchase.

What is Not Covered

This warranty is not transferable and does not cover (i) cosmetic damage, (ii) damage due to acts of God, accident, misuse, abuse, negligence, commercial use, or due to improper use, installation, operation or maintenance, (iii) modification of or to any part of the Product, (iv) attempted service by anyone other than a Horizon Hobby authorized service center, (v) Product not purchased from an authorized Horizon dealer, or (vi) Product not compliant with applicable technical regulations or (vii) use that violates any applicable laws, rules, or regulations. OTHER THAN THE EXPRESS WARRANTY ABOVE, HORIZON MAKES NO OTHER WARRANTY OR REPRESENTATION, AND HEREBY DISCLAIMS ANY AND ALL IMPLIED WARRANTIES,

INCLUDING, WITHOUT LIMITATION, THE IMPLIED WARRANTIES OF NON-INFRINGEMENT, MERCHANTABILITY AND FITNESS FOR A PARTICULAR PURPOSE. THE PURCHASER ACKNOWLEDGES THAT THEY ALONE HAVE DETERMINED THAT THE PRODUCT WILL SUITABLY MEET THE REQUIREMENTS OF THE PURCHASER'S INTENDED USE.

Purchaser's Remedy

Horizon's sole obligation and purchaser's sole and exclusive remedy shall be that Horizon will, at its option, either (i) service, or (ii) replace, any Product determined by Horizon to be defective. Horizon reserves the right to inspect any and all Product(s) involved in a warranty claim. Service or replacement decisions are at the sole discretion of Horizon. Proof of purchase is required for all warranty claims. SERVICE OR REPLACEMENT AS PROVIDED UNDER THIS WARRANTY IS THE PURCHASER'S SOLE AND EXCLUSIVE REMEDY.

Limitation of Liability

HORIZON SHALL NOT BE LIABLE FOR SPECIAL, INDIRECT, INCIDENTAL OR CONSEQUENTIAL DAMAGES, LOSS OF PROFITS OR PRODUCTION OR COMMERCIAL LOSS IN ANY WAY, REGARDLESS OF WHETHER SUCH CLAIM IS BASED IN CONTRACT, WARRANTY, TORT, NEGLIGENCE, STRICT LIABILITY OR ANY OTHER THEORY OF LIABILITY, EVEN IF HORIZON HAS BEEN ADVISED OF THE POSSIBILITY OF SUCH DAMAGES. Further, in no event shall the liability of Horizon exceed the individual price of the Product on which liability is asserted. As Horizon has no control over use, setup, final assembly, modification or misuse, no liability shall be assumed nor accepted for any resulting damage or injury. By the act of use, setup or assembly, the user accepts all resulting liability. If you as the purchaser or user are not prepared to accept the liability associated with the use of the Product, purchaser is advised to return the Product immediately in new and unused condition to the place of purchase.

Law

These terms are governed by Illinois law (without regard to conflict of law principals). This warranty gives you specific legal rights, and you may also have other rights which vary from state to state. Horizon reserves the right to change or modify this warranty at any time without notice.

WARRANTY SERVICES

Questions, Assistance, and Services

Your local hobby store and/or place of purchase cannot provide warranty support or service. Once assembly, setup or use of the Product has been started, you must contact your local distributor or Horizon directly. This will enable Horizon to better answer your questions and service you in the event that you may need any assistance. For questions or assistance, please visit our website at www.horizonhobby.com, submit a Product Support Inquiry, or call the toll free telephone number referenced in the Warranty and Service Contact Information section to speak with a Product Support representative.

Inspection or Services

If this Product needs to be inspected or serviced and is compliant in the country you live and use the Product in, please use the Horizon Online Service Request submission process found on our website or call Horizon to obtain a Return Merchandise Authorization (RMA) number. Pack the Product securely using a shipping carton. Please note that original boxes may be included, but are not designed to withstand the rigors of shipping without additional protection. Ship via a carrier that provides tracking and insurance for lost or damaged parcels, as Horizon is not responsible for merchandise until it arrives and is accepted at our facility. An Online Service Request is available at http://www.horizonhobby.com/content/service-center_render-service-center.

center_render-service-center. If you do not have internet access, please contact Horizon Product Support to obtain a RMA number along with instructions for submitting your product for service. When calling Horizon, you will be asked to provide your complete name, street address, email address and phone number where you can be reached during business hours. When sending product into Horizon, please include your RMA number, a list of the included items, and a brief summary of the problem. A copy of your original sales receipt must be included for warranty consideration. Be sure your name, address, and RMA number are clearly written on the outside of the shipping carton.

NOTICE: Do not ship Li-Po batteries to Horizon. If you have any issue with a Li-Po battery, please contact the appropriate Horizon Product Support office.

Warranty Requirements

For Warranty consideration, you must include your original sales receipt verifying the proof-of-purchase date. Provided warranty conditions have been met, your Product will be serviced or replaced free of charge. Service or replacement decisions are at the sole discretion of Horizon.

Non-Warranty Service

Should your service not be covered by warranty, service will be completed and payment will be required without notification or estimate of the expense unless the expense exceeds 50% of the retail purchase cost. By submitting the item for service you are agreeing to payment of the service without notification. Service estimates are available upon request. You must include this request with your item submitted for service. Non-warranty service estimates will be billed a minimum of ½ hour of labor. In addition you will be billed for return freight. Horizon accepts money orders and cashier's checks, as well as Visa, MasterCard, American Express, and Discover cards. By submitting any item to Horizon for service, you are agreeing to Horizon's Terms and Conditions found on our website http://www.horizonhobby.com/content/service-center_render-service-center.

ATTENTION: Horizon service is limited to Product compliant in the country of use and ownership. If received, a non-compliant Product will not be serviced. Further, the sender will be responsible for arranging return shipment of the un-serviced Product, through a carrier of the sender's choice and at the sender's expense. Horizon will hold non-compliant Product for a period of 60 days from notification, after which it will be discarded.

10/15

WARRANTY AND SERVICE CONTACT INFORMATION

Country of Purchase	Horizon Hobby	Contact Information	Address
United States of America	Horizon Service Center (Repairs and Repair Requests)	servicecenter.horizonhobby.com/RequestForm/	1608 Interstate Drive Champaign, Illinois 61822 USA*
	Horizon Product Support (Product Technical Assistance)	productsupport@horizonhobby.com 877-504-0233	
	Sales	websales@horizonhobby.com 800-338-4639	
European Union	Horizon Technischer Service	service@horizonhobby.eu +49 (0) 4121 2655 100	Hanskampring 9 D 22885 Barsbüttel, Germany
	Sales: Horizon Hobby GmbH		

*For the most up-to-date customer service contact information, please visit: www.horizonhobby.com/content/service-center-render-service-center

FCC STATEMENT

FCC ID: BRWDX2EQ2UC

FCC ID: BRWDASRX12

This equipment has been tested and found to comply with the limits for Part 15 of the FCC rules. These limits are designed to provide reasonable protection against harmful interference in a residential installation. This equipment generates uses and can radiate radio frequency energy and, if not installed and used in accordance with the instructions, may cause harmful interference to radio communications.

However, there is no guarantee that interference will not occur in a particular installation. If this equipment does cause harmful interference to radio or television reception, which can be determined by turning the equipment off and on, the user is encouraged to try to correct the interference by one or more of the following measures:

- Reorient or relocate the receiving antenna.
- Increase the separation between the equipment and receiver.
- Connect the equipment to an outlet on a circuit different from that to which the receiver is connected.
- Consult the dealer or an experienced radio/TV technician for help.

This device complies with part 15 of the FCC rules. Operation is subject to the following two conditions: (1) This device may not cause harmful interference, and (2) this device must accept any interference received, including interference that may cause undesired operation.

NOTICE: Modifications to this product will void the user's authority to operate this equipment.

IC INFORMATION

IC: 6157A-DX2EQ2UC

IC: 6157A-AMRX12

This device complies with Industry Canada licence-exempt RSS standard(s). Operation is subject to the following two conditions: (1) this device may not cause interference, and (2) this device must accept any interference, including interference that may cause undesired operation of the device.

COMPLIANCE INFORMATION FOR THE EUROPEAN UNION

EU Compliance Statement: Horizon Hobby, LLC hereby declares that this product is in compliance with the essential requirements and other relevant provisions of the RED and EMC Directive.

A copy of the EU Declaration of Conformity is available online at: <http://www.horizonhobby.com/content/support-render-compliance>.



Instructions for disposal of WEEE by users in the European Union

This product must not be disposed of with other waste. Instead, it is the user's responsibility to dispose of their waste equipment by handing it over to a designated collections point for the recycling of waste electrical and electronic equipment. The separate collection and recycling of your waste equipment at the time of disposal will help to conserve natural resources and ensure that it is recycled in a manner that protects human health and the environment. For more information about where you can drop off your waste equipment for recycling, please contact your local city office, your household waste disposal service or where you purchased the product.

REPLACEMENT PARTS // TEILELISTE // LISTE DES PIÈCES DE RECHANGE // ELENCO DEI RICAMBI

Part #	English	Deutsch	Français	Italiano
DYNS1495	Fuze Sport Brushless Motor: 3300Kv	Fuze Sport bürstenloser Motor: 3300 kV	Moteur sans balais Fuze Sport : 3 300 Kv	Motore Brushless Fuze Sport: 3300 Kv
DYNS2405	Fuze Sport Brushless ESC 60A	Fuze Sport bürstenloser ESC 60 A	Variateur ESC sans balais Fuze Sport 60 A	ESC Brushless Fuze Sport 60 A
LOSA4118	48 Pitch Pinion Gear, 18T	48 Pitchzahnradgetriebe, 23T	Engrenage à pignons pas 48, 23T	Pignone 48P, 23T
LOS230054	MAXXIS Body Set	MAXXIS Karosseriesatz	Carrosserie MAXXIS	Set carrozzeria MAXXIS
LOS230055	K&N Body Set	K&N Karosseriesatz	Carrosserie K&N	Set carrozzeria K&N
LOS230056	Body Set, Clear	Karosseriesatz, transparent	Carrosserie transparente	Set carrozzeria, trasparente
LOS231034	Mud Flaps	Schmutzfänger	Bavettes de garde-boue	Parafanghi
LOS231042	Chassis	Fahrgestell	Châssis	Telaio
LOS231043	Composite Steering Set	Komposit-Lenkungssatz	Ensemble de direction composite	Set sterzo in composito
LOS231044	Chassis Mounting Set	Fahrgestellstützatz	Support châssis	Set supporto telaio
LOS231045	Bulkhead Camber Black, Servo Mount	Spritzwandsturz schwarz, Servohalterung	Support de suspension, noir, support du servo	Paratia camber nero, supporto servo
LOS231046	Steering Hardware Set	Hardwaresatz Lenkung	Ensemble de matériel de direction	Set bulloneria sterzo
LOS231047	Body Mount Set	Karosseriehalterungssatz	Support de carrosserie	Set Supporto Carrozzeria
LOS231048	Front Bumper Set	Frontstoßstangensatz	Pare-choc avant	Set paraurti anteriore
LOS231049	Rear Bumper Set	Heckstoßstangensatz	Pare-choc arrière	Set paraurti posteriore
LOS231050	Steering Bearing Set	Lenklagersatz	Ensemble de roulement de direction	Set cuscinetti sterzo
LOS231051	Battery Mounting Foams	Schaumstoffe Akku-Halterung	Mousses de montage de batteries	Schiuma di montaggio per batteria
LOS232036	Gear Cover and Motor Guard	Getriebeabdeckung und Motorschutz	Cache de l'engrenage et protection moteur	Coperchio pignone e protezione motore
LOS232037	Transmission Case	Getriebeabdeckung	Boîtier de transmission	Scatola del cambio
LOS232038	Spur Gear and Slipper Pad 48P 84T	Stirnrad und Gleitkissen 48P 84T	Engrenage cylindrique et sabot de piston 48P 84T	Corona e pattino scorrevole 48P 84T
LOS232039	Complete Gear Differential	Komplettes Getriebe Differential	Engrenage différentiel complet	Differenziale pignone completo
LOS232040	Gear Set, Gear Differential	Getriebesatz, Getriebe Differential	Ensemble d'engrenages, engrenage différentiel	Set pignone, differenziale pignone
LOS232041	Motor Plate	Motorplatte	Plaque moteur	Piastra motore
LOS232042	Idler Gear and Shaft	Zwischenrad und Welle	Axe de pignon intermédiaire	Ingranaggio e albero folle
LOS232043	Layshaft and Gear	Zwischenwelle und Getriebe	Arbre intermédiaire et engrenage	Albero secondario e ingranaggio
LOS232044	Front Axle	Vorderachse	Essieu avant	Assale anteriore
LOS232045	CVA Driveshaft, Complete	CVA-Antriebswelle, komplett	Arbres de transmission CVA, complet	Albero di trasmissione CVA completo
LOS232046	Gear Differential Rebuild Set	Nachbausatz Getriebe Differential	Ensemble de reconstruction de l'engrenage différentiel	Set differenziale pignone rigenerato
LOS232047	Slipper Hardware Set	Hardwaresatz Gleiter	Ensemble de matériel du sabot	Set bulloneria scorrevole
LOS232048	Wheel Hex Set	Radsechskantsatz (4)	Hexagones de roues (4)	Set esagoni ruote (4)
LOS233016	Front Shock Set, Complete	Kompletter Vorderer Stoßdämpfersatz	Lot d'amortisseurs avant, complet	Set ammortizzatore anteriore completo
LOS233017	Rear Shock Set, Complete	Kompletter Hinterer Stoßdämpfersatz	Lot d'amortisseurs arrière, complet	Set ammortizzatore posteriore completo
LOS233018	Shock Body Set	Stoßdämpfergehäusesatz	Carrosserie amortisseurs	Set corpo ammortizzatore
LOS233019	Shock Shaft Set	Kolbenstangensatz	Lot de bras d'amortisseurs	Set albero ammortizzatore
LOS233020	Spring Set	Federsatz	Ressort	Set molle
LOS233021	Spring Cups and Clip Set	Satz mit Federtellern und Clips	Lot de coupelles de ressort et d'attaches	Set molle, coppe e clip
LOS233022	Shock Seal Set	Stoßdämpferdichtungssatz	Lot de joints d'amortisseurs	Set guarnizioni ammortizzatore
LOS233023	Shock Caps (2)	Stoßdämpferkappen (2)	Capuchons d'amortisseurs (2)	Tappi ammortizzatore (2)
LOS233024	Shock Ends	Stoßdämpferenden	Extrémités d'amortisseurs	Terminali ammortizzatore
LOS234024	Suspension Arm Set	Aufhängungsarmsatz	Lot de bras de suspension	Set braccetti sospensioni
LOS234025	Front Caster Block Set	Vorderradblocksatz	Lot de blocs de roulettes avant	Set blocco ruota anteriore
LOS234026	Hub and Spindle Set	Satz aus Nabe und Spindel	Lot de moyeux et de fusées	Set mozzo e fuselli
LOS234027	Camber and Steering Link Set	Satz aus Sturz und Lenkstange	Lot de timonerie de direction et de la chambre	Set camber e braccetti sterzo
LOS234028	Shock Tower Set	Stosdämpfersatz	Support d'amortisseurs	Set Torre Ammortizzatore
LOS234029	Pivot Set	Drehgelenksatz	Lot pivot	Set perni
LOS234030	Aluminum Front Chassis Plate	Vordere Aluminium-Karosserieplatte	Plaque châssis avant en aluminium	Piastra anteriore telaio in alluminio
LOS234031	Aluminum Rear Chassis Plate	Hintere Aluminium-Karosserieplatte	Plaque châssis arrière en aluminium	Piastra posteriore telaio in alluminio
LOS234032	Hinge Pin Set	Scharnierbolzensatz	Lot de charnière	Set piastrine per perni
LOS234033	Hinge Pin Lock Screws	Scharnierbolzen-Sicherungsstifte	Vis de blocage de charnière	Viti di supporto piastrine per perni
LOS234034	Ball Stud, 4.8mm x 6mm (4)	Kugelzapfen, 4,8 mm x 6 mm (4)	Piton à rotule, 4,8 mm x 6 mm (4)	Viti a sfera, 4,8 mm x 6 mm (4)
LOS235003	Cap Head Screws M3 x 6mm (10)	Inbusschrauben M3 x 6 mm (10)	Vis à tête bombée, M3 x 6 mm (10)	Viti a testa cilindrica, M3 x 6 mm (10)
LOS235018	Set Screws, M3 X 3mm (10)	Stellschrauben, M3 x 3 mm (10)	Vis de fixation, M3 x 3 mm (10)	Viti di fermo, M3 x 3 mm (10)
LOS235024	Button Head Screws M3 x 25mm (10)	Halbrundschrauben, M3 x 25 mm (10)	Vis à tête bombée M3 x 25mm (10)	Viti a testa tonda, M3 x 25 mm (10)
LOS235028	Flat Head Screws M3 x 45mm (6)	Flachkopfschrauben, M3 x 45 mm (6)	Vis à tête fraisée, M3 x 45mm (6)	Viti a testa piatta, M3 x 45 mm (6)
LOS235029	Cap Head Screws M2 x 4mm (10)	Inbusschrauben M2 x 4 mm (10)	Vis à tête bombée, M2 x 4 mm (10)	Viti a testa cilindrica, M2 x 4 mm (10)
LOS43015	Wheel and Tire Mounted (2)	Montiertes Rad und Reifen (2)	Support volant et pneu (2)	Ruota con pneumatico montato (2)
LOSA4002	DISC by LOS Antenna Kit	DISC by LOS Antennensatz	Kit d'antenne DISC par LOS	Kit antenna DISC by LOS
LOSA6937	5 x 10mm Shielded Ball Bearing (2)	5 x 10 mm abgedichtetes Kugellager (2)	Roulement à billes blindé 5 x 10 mm (2)	Cuscinetti a sfera schermati 5 x 10 mm (2)
LOSA6955	5 x 13mm HD Clutch Bearings (2)	5 x 13 mm HD Kupplungslager (2)	Roulements à embrayage ultra-résistant 5 x 13 mm (2)	Cuscinetti frizione HD 5 x 13mm (2)
LOSA6957	10 x 15 x 4mm BB (2) w/ Nylon Retainer	10 x 15 x 4 mm BB (2) mit Nylon-Halter	Roulements à billes 10 x 15 x 4 mm (0) avec bague de retenue en nylon	Cuscinetto a sfera 10 x 15 x 4mm (2) con fermo in nylon
SPM2335	DX2E Active 2Ch DSMR Radio w/SR310	DX2e Active 2-Kanal Oberflächen-Funkgerät	Émetteur DX2e Active 2 voies	Radiocomando di superficie DX2e Active 2 canali
SPMSRS6000	SRS6000 DSMR AVC Surface Receiver	SRS6000 DSMR AVC Oberflächenempfänger	Récepteur Surface SRS6000 DSMR AVC	Ricevente di superficie SRS6000 DSMR con AVC
TLR235004	Flat Head Screws, M3 x 25mm (10)	Flachkopfschrauben, M3 x 25 mm (10)	Vis à tête fraisée, M3 x 25mm (10)	Viti a testa piatta, M3 x 25 mm (10)
TLR235007	Flat Head Screws M2.5 x 10mm (10)	Flachkopfschrauben, M2.5 x 10 mm (10)	Vis à tête fraisée, M2.5 x 10mm (10)	Viti a testa piatta, M2.5 x 10 mm (10)
TLR5092	Upper Shock Bushing (4)	Oberes Dämpferlager (4)	Bague d'amortisseurs supérieurs (4)	Boccole ammortizzatore superiore (4)
TLR5900	Button Head Screws, M3 x 5mm (10)	Halbrundschrauben, M3 x 5 mm (10)	Vis à tête bombée M3 x 5mm (10)	Viti a testa tonda, M3 x 5 mm (10)
TLR5901	Button Head Screws, M3 x 6mm (10)	Halbrundschrauben, M3 x 6 mm (10)	Vis à tête bombée M3 x 6mm (10)	Viti a testa tonda, M3 x 6 mm (10)

REPLACEMENT PARTS // TEILELISTE // LISTE DES PIÈCES DE RECHANGE // ELENCO DEI RICAMBI

Part #	English	Deutsch	Français	Italiano
TLR5902	Button Head Screws, M3 x 8mm (10)	Halbrundschrauben, M3 x 8 mm (10)	Vis à tête bombée M3 x 8mm (10)	Viti a testa tonda, M3 x 8 mm (10)
TLR5903	Button Head Screws, M3 x 10mm (10)	Halbrundschrauben, M3 x 10 mm (10)	Vis à tête bombée M3 x 10mm (10)	Viti a testa tonda, M3 x 10 mm (10)
TLR5904	Button Head Screws, M3 x 12mm (10)	Halbrundschrauben, M3 x 12 mm (10)	Vis à tête bombée M3 x 12mm (10)	Viti a testa tonda, M3 x 12 mm (10)
TLR5906	Button Head Screws, M3 x 35mm (10)	Halbrundschrauben, M3 x 35 mm (10)	Vis à tête bombée M3 x 35mm (10)	Viti a testa tonda, M3 x 35 mm (10)
TLR5909	Button Head Screws, M3 x 16mm (10)	Halbrundschrauben, M3 x 16 mm (10)	Vis à tête bombée M3 x 16mm (10)	Viti a testa tonda, M3 x 16 mm (10)
TLR5910	Button Head Screws M3 x 14mm (10)	Halbrundschrauben, M3 x 14 mm (10)	Vis à tête bombée M3 x 14mm (10)	Viti a testa tonda, M3 x 14 mm (10)
TLR5911	Button Head Screws, M3 x 20mm (10)	Halbrundschrauben, M3 x 20 mm (10)	Vis à tête bombée M3 x 20mm (10)	Viti a testa tonda, M3 x 20 mm (10)
TLR5912	Button Head Screws, M3 x 54mm (2)	Halbrundschrauben, M3 x 54 mm (2)	Vis à tête bombée M3 x 54mm (2)	Viti a testa tonda, M3 x 54 mm (2)
TLR5914	Button Head Screws, M2 x 12mm (10)	Halbrundschrauben, M2 x 12 mm (10)	Vis à tête bombée M2 x 12mm (10)	Viti a testa tonda, M2 x 12 mm (10)
TLR5961	Flat Head Screws, M3 x 8mm (10)	Flachkopfschrauben, M3 x 8 mm (10)	Vis à tête fraisée, M3 x 8mm (10)	Viti a testa piatta, M3 x 8 mm (10)
TLR5962	Flat Head Screws, M3 x 10mm (10)	Flachkopfschrauben, M3 x 10 mm (10)	Vis à tête fraisée, M3 x 10mm (10)	Viti a testa piatta, M3 x 10 mm (10)
TLR5963	Flat Head Screws, M3 x 12mm (10)	Flachkopfschrauben, M3 x 12 mm (10)	Vis à tête fraisée, M3 x 12mm (10)	Viti a testa piatta, M3 x 12 mm (10)
TLR6105	E-Clips, 3mm Shaft (12)	E-Clips 3 mm (12)	E-Clips 3mm (12)	E-clip 3 mm (12)
TLR6276	Set Screws, M2.5 x 5mm, Cup Point (10)	Stellschrauben, M2.5 x 5 mm Ringschneide (10)	Vis STHC M2.5 x 5mm CUV (10)	Grani, M2.5 x 5 mm con punta a coppa (10)
TLR6288	Set Screws, M3 x 2.5mm (10)	Stellschraube, M3 x 2,5 mm (10)	Vis de fixation, M3 x 2,5 mm (10)	Set viti, M3 x 2,5 mm (10)
TLR6313	Locknut, M3 x .5 x 5.5mm (10)	Einstellmutter, M3 x .5 x 5.5 mm (10)	Écrou auto-freiné, M3 x .5 x 5.5mm (10)	Dado Nylock, M3 x .5 x 5.5 mm (10)
TLR6352	Washers, M3 (10)	Unterlegscheiben, M3 (10)	Rondelles, M3 (10)	Rondelle, M3 (10)
TLR8202	Body Clips, Black (12): 22	Karosseriekammern, Schwarz (12): 22	22 - Clips de carrosserie noirs (12)	Clip carrozzeria, nero (12): 22
VR235178	Flat Head Screws, M3 x 14mm (10)	Flachkopfschrauben, M3 x 14 mm (10)	Vis à tête fraisée, M3 x 14mm (10)	Viti a testa piatta, M3 x 14 mm (10)

RECOMMENDED PARTS // EMPFOHLENE TEILE // PIÈCES RECOMMANDÉES // PEZZI RACCOMANDATI

Part #	English	Deutsch	Français	Italiano
DYN1510	Powerstage Bundle - Stage 2	Leistungsteilpaket – Stufe 2	Lot à étage de puissance : étape 2	Bundle Powerstage - fase 2
DYN1520	Powerstage Bundle - Stage 3	Leistungsteilpaket – Stufe 3	Lot à étage de puissance : étape 3	Bundle Powerstage - fase 3
DYNB3803EC	11.1V 5000mAh 3S 50C LiPo, Hardcase: EC3	11,1 V 5000 mA 3S 50C LiPo, Hartschale: EC3	Batterie Li-Po 11,1 V 5 000 mAh 3S 50C, boîtier rigide : EC3	11,1 V 5000 mAh 3S 50C LiPo, Hardcase: EC3
DYNC2030	Prophet Sport Mini 50W Charger	Prophet Sport Mini 50 W Ladegerät	Chargeur 50W Prophet Sport Mini	Caricabatterie Prophet Sport Mini 50 W
SPM6743	DX2E Active Speedometer Bundle	DX2E Active Tachometer-Bündel	Lot de compteurs de vitesse DX2E Active	Bundle tachimetro DX2E Active
SPM6744	DX2E Active Dashboard Bundle	DX2E Active Armatur-Bündel	Lot de tableaux de bord DX2E Active	Bundle cruscotto DX2E Active

OPTIONAL PARTS // OPTIONALE TEILE // PIÈCES OPTIONNELLES // PARTI OPZIONALI

Part #	English	Deutsch	Français	Italiano
DYN2950	8-in-1 Hex Wrench Kit	8-in-1 Sechskantschlüsselsatz	Kit de clés hexagonales 8-en-1	Kit chiavi esagonale 8 in 1
DYN4401	GPS Speed Meter	GPS-Tachometer	Indicateur de vitesse GPS	Tachimetro GPS
DYN9004EC	7.4V 5000mAh 2S 20C LiPo, Case: EC3	7,4 V 5000 mA 2S 20C LiPo, Schale: EC3	Batterie Li-Po 7,4V 5 000 mAh 2S 20C, boîtier : EC3	7,4 V 5000 mAh 2S 20C LiPo, Case: EC3
DYN9005EC	7.4V 5000mAh 2S 30C LiPo, Case: EC3	7,4 V 5000 mA 2S 30C LiPo, Schale: EC3	Batterie Li-Po 7,4V 5 000 mAh 2S 30C, boîtier : EC3	7,4 V 5000 mAh 2S 30C LiPo, Case: EC3
DYN9007EC	11.1V 5000mAh 3S 30C LiPo, Case: EC3	11,1 V 5000 mA 3S 50C LiPo, Schale: EC3	Batterie Li-Po 11,1V 5 000 mAh 3S 30C, boîtier : EC3	11,1 V 5000 mAh 3S 30C LiPo, Case: EC3
LOS43006	Wheels (4)	Räder (4)	Roues (4)	Ruote (4)
LOS43016	Maxxis Razr MT, SCT Tire (2)	Maxxis Razr MT, SCT Reifen (2)	Pneu SCT, Maxxis Razr MT (2)	Maxxis Razr MT, Pneumatici SCT (2)
LOSA99174	Car Stand	Fahrzeugständer	Socle	Supporto automodello
SPMS605	9KG Servo, WP, Metal Center Case, 23T	9 kg Servo, WP, zentrales Metallgehäuse, 23T	Servo 9KG, WP, carter central en métal, 23T	Servo 9KG, WP, custodia cent. metallo, 23T
TLR33201	48P Aluminum Pinion Gear, 18T	48P Aluminium Zahnradgetriebe, 18T	Engrenage à pignons en aluminium 48P, 18T	Pignone alluminio 48P, 18T
TLR232009	HDS Spur Gear 76T 48P Kevlar®	HDS Stimrad 76T 48P Kevlar	Engrenage HDS 76T 48P Kevlar	Corona HDS 76T 48P Kevlar
TLR232010	HDS Spur Gear 78T 48P Kevlar®	HDS Stimrad 78T 48P Kevlar	Engrenage HDS 78T 48P Kevlar	Corona HDS 78T 48P Kevlar
TLR232011	HDS Spur Gear 82T 48P Kevlar®	HDS Stimrad 78T 82P Kevlar	Engrenage HDS 82T 48P Kevlar	Corona HDS 82T 48P Kevlar
TLR332017	48P Aluminum Pinion Gear, 17T	48P Aluminium Zahnradgetriebe, 17T	Engrenage à pignons en aluminium 48P, 17T	Pignone alluminio 48P, 17T
TLR332019	48P Aluminum Pinion Gear, 19T	48P Aluminium Zahnradgetriebe, 19T	Engrenage à pignons en aluminium 48P, 19T	Pignone alluminio 48P, 19T
TLR332020	48P Aluminum Pinion Gear, 20T	48P Aluminium Zahnradgetriebe, 20T	Engrenage à pignons en aluminium 48P, 20T	Pignone alluminio 48P, 20T
TLR332021	48P Aluminum Pinion Gear, 21T	48P Aluminium Zahnradgetriebe, 21T	Engrenage à pignons en aluminium 48P, 21T	Pignone alluminio 48P, 21T
TLR332022	48P Aluminum Pinion Gear, 22T	48P Aluminium Zahnradgetriebe, 22T	Engrenage à pignons en aluminium 48P, 22T	Pignone alluminio 48P, 22T
TLR332023	48P Aluminum Pinion Gear, 23T	48P Aluminium Zahnradgetriebe, 23T	Engrenage à pignons en aluminium 48P, 23T	Pignone alluminio 48P, 23T
TLR336000	4mm Aluminum Serrated Lock Nuts, Black (6)	4 mm Aluminium Rändelmutter, schwarz (6)	Contre-écrous en aluminium à embase striée 4 mm, noir (6)	Controdado dentato in alluminio 4 mm, nero (6)
TLR336001	4mm Aluminum Serrated Lock Nuts, Blue (6)	4 mm Aluminium Rändelmutter, blau (6)	Contre-écrous en aluminium à embase striée 4 mm, bleu (6)	Controdado dentato in alluminio 4 mm, blu (6)
TLR74004	Silicone Shock Oil, 25 wt, 2 oz	Stoßdämpfer-Silikonöl, 25 wt, 59 ml (2 oz)	Huile de silicone pour amortisseurs, 25 wt, 2 oz	Olio di silicone ammortizzatore, 25 wt, 2 oz
TLR74005	Silicone Shock Oil, 27.5 wt, 2 oz	Stoßdämpfer-Silikonöl, 27,5 wt, 59 ml (2 oz)	Huile de silicone pour amortisseurs, 27,5 wt, 2 oz	Olio di silicone ammortizzatore, 27,5 wt, 2 oz
TLR74006	Silicone Shock Oil, 30 wt, 2 oz	Stoßdämpfer-Silikonöl, 30 wt, 59 ml (2 oz)	Huile de silicone pour amortisseurs, 30 wt, 2 oz	Olio di silicone ammortizzatore, 30 wt, 2 oz
TLR74008	Silicone Shock Oil, 35 wt, 2 oz	Stoßdämpfer-Silikonöl, 35 wt, 59 ml (2 oz)	Huile de silicone pour amortisseurs, 35 wt, 2 oz	Olio di silicone ammortizzatore, 35 wt, 2 oz
TLR74009	Silicone Shock Oil, 37.5 wt, 2 oz	Stoßdämpfer-Silikonöl, 37,5 wt, 59 ml (2 oz)	Huile de silicone pour amortisseurs, 37,5 wt, 2 oz	Olio di silicone ammortizzatore, 37,5 wt, 2 oz
TLR76000	Tire Glue, Standard	Reifenklebemittel, Standard	Colle à pneus, standard	Colla pneumatici, standard
TLR76004	TLR Lok, Threadlock, Blue	TLR Lok, Schraubensicherung, blau	Verrou TLR, frein-filet, bleu	TLR Lok, frenafilet, blu

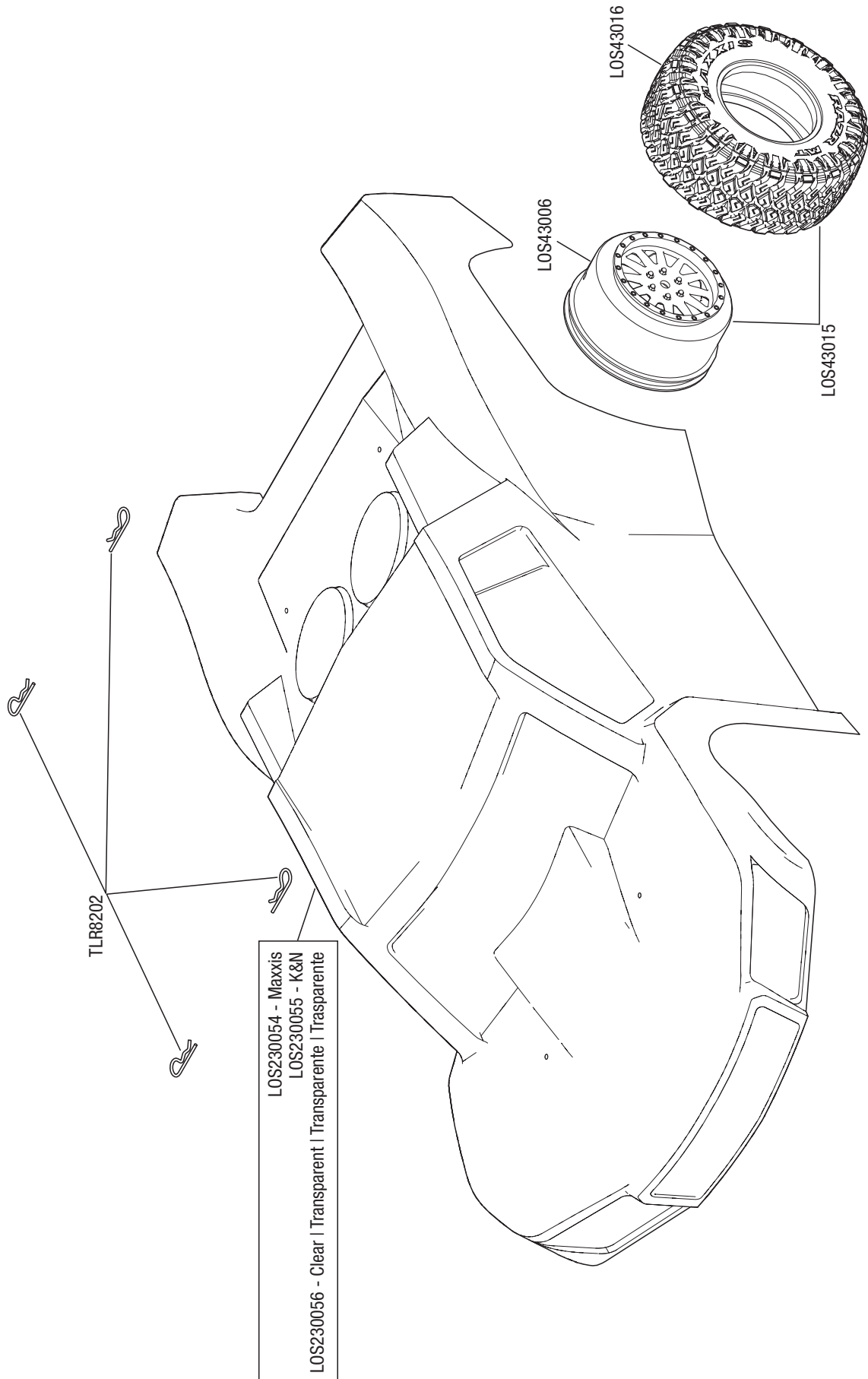

EXPLODED VIEW // EXPLOSIONSZEICHNUNG // VUE ÉCLATÉE DES PIÈCES // VISTA ESPLOSA DELLE PARTI

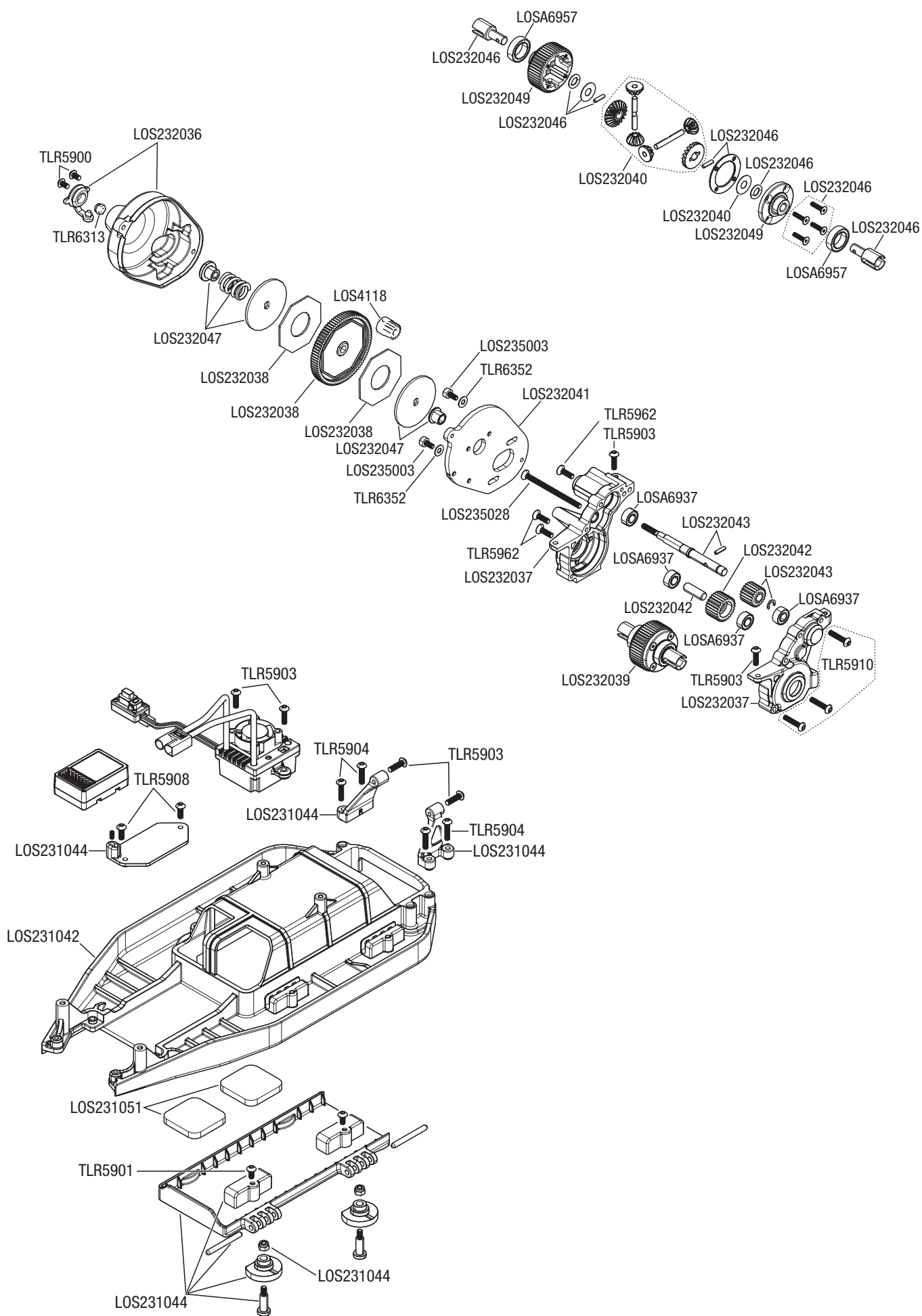



WWW.LOSI.COM

©2018 Horizon Hobby, LLC.

Losi, 22S, DSM, DSM2, DSMR, AVC, Active Vehicle Control, EC3, Dynamite, Fuze, Prophet and the Horizon Hobby logo are trademarks or registered trademarks of Horizon Hobby, LLC. The Spektrum trademark is used with permission of Bachmann Industries, Inc. Maxxis, Magnaflow, Kicker, K&N, and associated logos are property of their respective owners and are used with permission. US 9,320,977. Other patents pending.

Created 04/18

54553

LOS03013T1/T2