



Bind-N-Drive.™ Ready to run, redefined.

AVC® U.S. Pat. No. 9,320,977

Super BAJAREY®



**INSTRUCTION MANUAL
BEDIENUNGSANLEITUNG
MANUEL D'UTILISATION
MANUALE DI ISTRUZIONI**



Before operating this vehicle, please read all printed materials thoroughly.
Horizon Hobby is not responsible for inadvertent errors in this manual.

NOTICE

All instructions, warranties and other collateral documents are subject to change at the sole discretion of Horizon Hobby, LLC. For up-to-date product literature, visit horizonhobby.com and click on the support tab for this product.

MEANING OF SPECIAL LANGUAGE

The following terms are used throughout the product literature to indicate various levels of potential harm when operating this product:

WARNING: Procedures, which if not properly followed, create the probability of property damage, collateral damage, and serious injury OR create a high probability of superficial injury.

CAUTION: Procedures, which if not properly followed, create the probability of physical property damage AND a possibility of serious injury.

NOTICE: Procedures, which if not properly followed, create a possibility of physical property damage AND a little or no possibility of injury.

 **WARNING:** Read the ENTIRE instruction manual to become familiar with the features of the product before operating. Failure to operate the product correctly can result in damage to the product, personal property and cause serious injury.

This is a sophisticated hobby product. It must be operated with caution and common sense and requires some basic mechanical ability. Failure to operate this Product in a safe and responsible manner could result in injury or damage to the product or other property. This product is not intended for use by children without direct adult supervision. Do not use with incompatible components or alter this product in any way outside of the instructions provided by Horizon Hobby, LLC. This manual contains instructions for safety, operation and maintenance. It is essential to read and follow all the instructions and warnings in the manual, prior to assembly, setup or use, in order to operate correctly and avoid damage or serious injury.

 **WARNING AGAINST COUNTERFEIT PRODUCTS:** Always purchase from a Horizon Hobby, LLC authorized dealer to ensure authentic high-quality Spektrum product. Horizon Hobby, LLC disclaims all support and warranty with regards, but not limited to, compatibility and performance of counterfeit products or products claiming compatibility with DSM or Spektrum technology.

Age Recommendation: Not for children under 14 years. This is not a toy.

SAFETY PRECAUTIONS AND WARNINGS

As the user of this product, you are solely responsible for operating in a manner that does not endanger yourself and others or result in damage to the product or property of others.

This model is controlled by a radio signal subject to interference from many sources outside your control. This interference can cause momentary loss of control, so it is advisable to always keep a safe distance in all directions around your model as this margin will help avoid collisions or injury.

- Never operate your model with low transmitter batteries.
- Always operate your model in open spaces away from full-size vehicles, traffic and people.
- Never operate the model in the street or in populated areas for any reason.
- Carefully follow the directions and warnings for this and any optional support equipment (chargers, rechargeable battery packs, etc.) you use.
- Keep all chemicals, small parts and anything electrical out of the reach of children.

- Never lick or place any portion of the model in your mouth as it could cause serious injury or even death.
- Exercise caution when using tools and sharp instruments.
- Take care during maintenance as some parts may have sharp edges.
- Immediately after using your model, do NOT touch equipment such as the motor, electronic speed control and battery, because they generate high temperatures. You may burn yourself seriously touching them.
- Do not put fingers or any objects inside rotating and moving parts, as this may cause damage or serious injury.
- Always turn on your transmitter before you turn on the receiver in the car. Always turn off the receiver before turning your transmitter off.
- Keep the wheels of the model off the ground when checking the operation of the radio equipment.

WATER-RESISTANT VEHICLE WITH WATERPROOF ELECTRONICS

Your new Horizon Hobby vehicle has been designed and built with a combination of waterproof and water-resistant components to allow you to operate the product in many "wet conditions," including puddles, creeks, wet grass, snow and even rain.

While the entire vehicle is highly water-resistant, it is not completely waterproof and your vehicle should NOT be treated like a submarine. The various electronic components used in the vehicle, such as the Electronic Speed Control (ESC), servo(s) and receiver are waterproof, however, most of the mechanical components are water-resistant and should not be submerged.

Metal parts, including the bearings, hinge pins, screws and nuts, as well as the contacts in the electrical cables, will be susceptible to corrosion if additional maintenance is not performed after running in wet conditions. To maximize the long-term performance of your vehicle and to keep the warranty intact, the procedures described in the "Wet Conditions Maintenance" section below must be performed regularly if you choose to run in wet conditions. If you are not willing to perform the additional care and maintenance required, then you should not operate the vehicle in those conditions.

 **CAUTION:** Failure to exercise caution while using this product and complying with the following precautions could result in product malfunction and/or void the warranty.

GENERAL PRECAUTIONS

- Read through the wet conditions maintenance procedures and make sure that you have all the tools you will need to properly maintain your vehicle.
- Not all batteries can be used in wet conditions. Consult the battery manufacturer before use. Caution should be taken when using Li-Po batteries in wet conditions.
- Most transmitters are not water-resistant. Consult your transmitter's manual or the manufacturer before operation.
- Never operate your transmitter or vehicle where lightning may be present.
- Do not operate your vehicle where it could come in contact with salt water (ocean water or water on salt-covered roads), contaminated or polluted water. Salt water is very conductive and highly corrosive, so use caution.
- Even minimal water contact can reduce the life of your motor if it has not been certified as water-resistant or waterproof. If the motor becomes excessively wet, apply very light

throttle until the water is mostly removed from the motor. Running a wet motor at high speeds may rapidly damage the motor.

- Driving in wet conditions can reduce the life of the motor. The additional resistance of operating in water causes excess strain. Alter the gear ratio by using a smaller pinion or larger spur gear. This will increase torque (and motor life) when running in mud, deeper puddles, or any wet conditions that will increase the load on the motor for an extended period of time.

WET CONDITIONS MAINTENANCE

- Drain any water that has collected in the tires by spinning them at high speed. With the body removed, place the vehicle upside down and pull full throttle for a few short bursts until the water has been removed.

 **CAUTION:** Always keep hands, fingers, tools and any loose or hanging objects away from rotating parts when performing the above drying technique.

- Remove the battery pack(s) and dry the contacts. If you have an air compressor or a can of compressed air, blow out any water that may be inside the recessed connector housing.
- Remove the tires/wheels from the vehicle and gently rinse the mud and dirt off with a garden hose. Avoid rinsing the bearings and transmission.

NOTICE: Never use a pressure washer to clean your vehicle.

- Use an air compressor or a can of compressed air to dry the vehicle and help remove any water that may have gotten into small crevices or corners.
- Spray the bearings, drive train, fasteners and other metal parts with a water-displacing light oil. Do not spray the motor.
- Let the vehicle air dry before you store it. Water (and oil) may continue to drip for a few hours.
- Increase the frequency of disassembly, inspection and lubrication of the following:
 - Front and rear axle hub assembly bearings.
 - All transmission cases, gears and differentials.
 - Motor—clean with an aerosol motor cleaner and re-oil the bushings with lightweight motor oil.

QUICK START

Please read the entire manual to gain a full understanding of the Baja Rey vehicle, fine-tuning the setup and performing maintenance.

1. Read the safety precautions found in this manual.
2. Charge a battery for the vehicle. Refer to the included charging warnings and instructions for battery charging information.
3. Install the AA batteries in the transmitter. Only use alkaline or rechargeable batteries.
4. Install the fully charged battery in the vehicle.
5. Power ON the transmitter and then the vehicle. Wait 5 seconds for the ESC to initialize. Always power the transmitter ON before the vehicle and power it OFF after the vehicle has been powered OFF.
6. Check the steering and throttle control directions. Verify that the servos are moving in the correct direction.
7. Drive your vehicle.
8. Perform any necessary maintenance.

CHARGING THE BATTERY

Choose batteries designed to work with the Dynamite® Fuze™ 160A Brushless Waterproof ESC. We recommend standard LiPo batteries: the Dynamite® 7.4V 5000mAh 2S 50C LiPo: Hardcase with EC5™ connector (DYNB3810EC) or the Dynamite® 11.1V 5000mAh 3S 50C LiPo: Hardcase with EC5™ connector (DYNB3811EC) -or- HV LiPo batteries: the Dynamite® 7.6V 5000mAh 2S 50C LiPo: Hardcase with EC5™ connector (DYNB3855EC) or the Dynamite® 11.4V 5000mAh 3S 50C LiPo: Hardcase with EC5™ connector (DYNB3856EC).

Choose a charger designed to charge Li-Po batteries. We recommend the Dynamite® Passport Duo 400W Dual AC/DC Touch Charger (DYNC3005) or the Dynamite® Passport Ultra 100W AC/DC Touch Charger (DYNC3000). Refer to your battery and charger manuals for usage, safety, and charging information.

TABLE OF CONTENTS

SAFETY PRECAUTIONS AND WARNINGS	2
WATER-RESISTANT VEHICLE WITH WATERPROOF ELECTRONICS	2
QUICK START	3
CHARGING THE BATTERY	3
BOX CONTENTS	3
SRS6000 AVC® TECHNOLOGY RECEIVER	4
SRS6000 STABILITY ASSIST RECEIVER	4
DISABLING AVC® TECHNOLOGY	4
BINDING/CALIBRATING THE RECEIVER	4
INSTALLING THE BATTERY	5
DRIVING PRECAUTIONS	5
BEFORE RUNNING YOUR VEHICLE	5
POWERING ON THE VEHICLE	5
PERFORMING A CONTROL DIRECTION TEST	6
RUN TIME	6
POWERING OFF THE VEHICLE	6
DYNAMITE FUZE 1200KV BRUSHLESS MOTOR	6
ESC FUNCTIONS	7
TROUBLESHOOTING GUIDE	8
LIMITED WARRANTY	8
WARRANTY AND SERVICE CONTACT INFORMATION	9
FCC INFORMATION	9
IC INFORMATION	9
COMPLIANCE INFORMATION FOR THE EUROPEAN UNION	9
REPLACEMENT PARTS	33–34
OPTIONAL PARTS	35
EXPLODED VIEWS	35–39

BOX CONTENTS

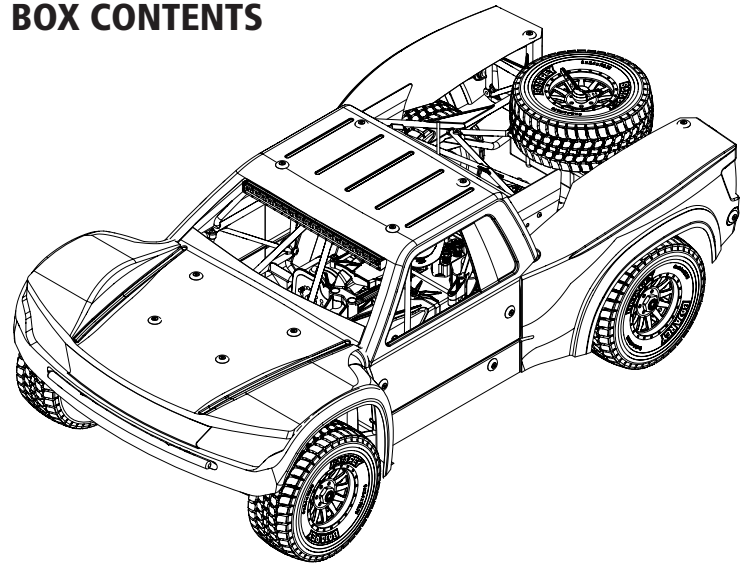

- Losi® Super Baja Rey® RTR with AVC® Technology: 1/6-Scale 4WD Desert Truck (LOS05018)
- Spektrum™ 6-Channel DSMR® AVC2 Surface Receiver (SPMSRS6000)
- Spektrum™ 18KG Waterproof 1/5-Scale Servo (SPMS904)
- Dynamite® Fuze™ 160A BLWP 1/5-Scale ESC: 8S (DYNS2661)
- Dynamite® Fuze™ Brushless Motor 1200kv (DYNS1660)

REGISTER YOUR LOSI PRODUCT ONLINE

Register your vehicle now and be the first to find out about the latest option parts, product updates and more. Click on the Support tab at www.losi.com and follow the product registration link to stay connected.

SRS6000 AVC® TECHNOLOGY RECEIVER

AUX CHANNELS

The Aux channels can operate as additional servo channels, or as a power supply for a personal transponder.

If AVC is active, only 4 channels; Steering, Throttle, AUX3 and AUX4 are operational. The remaining Aux channels can be used to power a personal transponder or lights.

If AVC is disabled (see DISABLING THE STABILITY ASSIST FUNCTION), all 6 channels (including the Aux channels) can operate as servo channels.

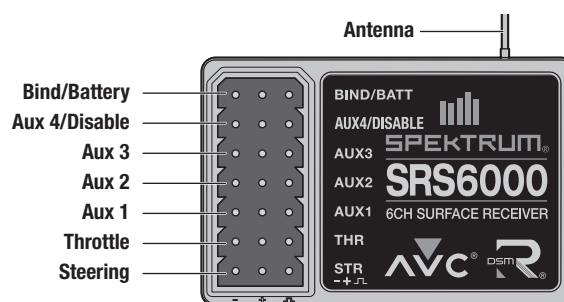

SRS6000 STABILITY ASSIST RECEIVER

ACTIVE VEHICLE CONTROL™ (AVC®)

The Spektrum receiver features Active Vehicle Control™ (AVC®) technology that responds similar to traction control in full-scale vehicles. In addition to traction control, AVC technology also increases steering stability during high speed driving or while driving over rough terrain. As you increase the AVC sensitivity, the system increases steering stability and traction control, similar to reducing the amount of steering rate in a computer transmitter. Reducing the sensitivity value increases the amount of steering control from the transmitter. The receiver also enables you to quickly turn AVC on or off if you participate in organized racing.

IMPORTANT: You must use digital servos with the AVC receiver. Do not use analog servos as they will reduce the performance of the system and may cause overheating.

AVC® SENSITIVITY

The ST RATE dial adjusts the sensitivity, or stability, value in the receiver. If you increase the sensitivity, the AVC® system becomes more sensitive to the vehicle drifting left or right. You would use maximum sensitivity during high speed driving or drag racing, when you want the vehicle to stay in a straight line. As the sensitivity value increases, the amount of steering travel decreases.

Turn the AVC/ST RATE knob counter-clockwise to reduce the sensitivity.

Turn the AVC/ST RATE knob clockwise to increase the sensitivity.

IMPORTANT: The ST RATE knob will only adjust the sensitivity when the transmitter is bound to a DSMR® AVC® receiver. When the transmitter is bound to a DSM2®/DSMR non AVC receiver, the ST RATE knob controls the steering dual rate.

DISABLING AVC® TECHNOLOGY

If you participate in organized racing, you may be required to turn AVC off. To turn AVC off:

1. Insert a Bind Plug in the BIND port on the receiver.
2. Insert a second Bind Plug in the DISABLE port on the receiver.
3. Connect a fully charged battery pack to the ESC.
4. Power on the ESC. The orange LED flashes, indicating the receiver is in bind mode.
5. Center the ST TRIM and TH TRIM dials on the transmitter.
6. Press and hold the BIND button while powering on the transmitter.
7. Release the BIND button when the orange LED slowly flashes. The transmitter and receiver are linked when the orange LED is solid.
8. Pull the transmitter trigger to Full Throttle.
9. Push the transmitter trigger to Full Brake, then return the trigger to center.
10. Turn the transmitter steering wheel to Full Right.
11. Turn the transmitter steering wheel to Full Left, then return the steering wheel to center. The orange LED flashes once.
12. Remove the Bind Plugs, then power off the receiver to save the settings. The receiver will continuously blink to indicate AVC is disabled.
13. Power off the transmitter.

IMPORTANT: You must calibrate the receiver each time it is placed in bind mode. To activate AVC, see the steps in "Calibrating the Receiver."

BINDING/CALIBRATING THE RECEIVER

BINDING

Binding is the process of programming the receiver to recognize the GUID (Globally Unique Identifier) code of a single specific transmitter. When a receiver is bound to a transmitter/model memory, the receiver will only respond to that specific transmitter/model memory.

Your Spektrum DX2E transmitter comes prebound to the vehicle. If you need to rebind or calibrate, follow the instructions below.

1. With the vehicle on a flat, level surface, insert the Bind Plug in the BIND port on the receiver.
2. Connect a fully charged battery pack to the ESC.
3. Power on the ESC. The orange LED flashes on the receiver, indicating it is in bind mode.
4. Center the ST TRIM and TH TRIM dials on the transmitter.
5. Press and hold the BIND button while powering on the transmitter.
6. Release the BIND button when the orange LED slowly flashes. The transmitter and receiver are linked when the orange LED is solid.

CALIBRATING (continue from step 6 above)

7. Pull the transmitter trigger to Full Throttle, the orange LED will flash once.
8. Push the transmitter trigger to Full Brake, then return the trigger to center.
9. Turn the transmitter steering wheel to Full Right. The orange LED flashes.
10. Turn the transmitter steering wheel to Full Left, then return the steering wheel to center. The orange LED flashes once.
11. Remove the Bind Plug, then power off the receiver to save the settings.
12. Power off the transmitter.

INSTALLING THE BATTERIES

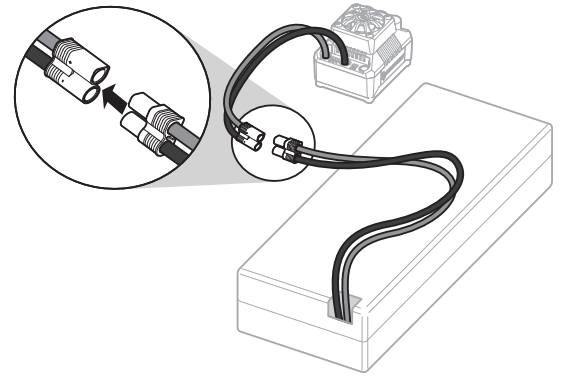
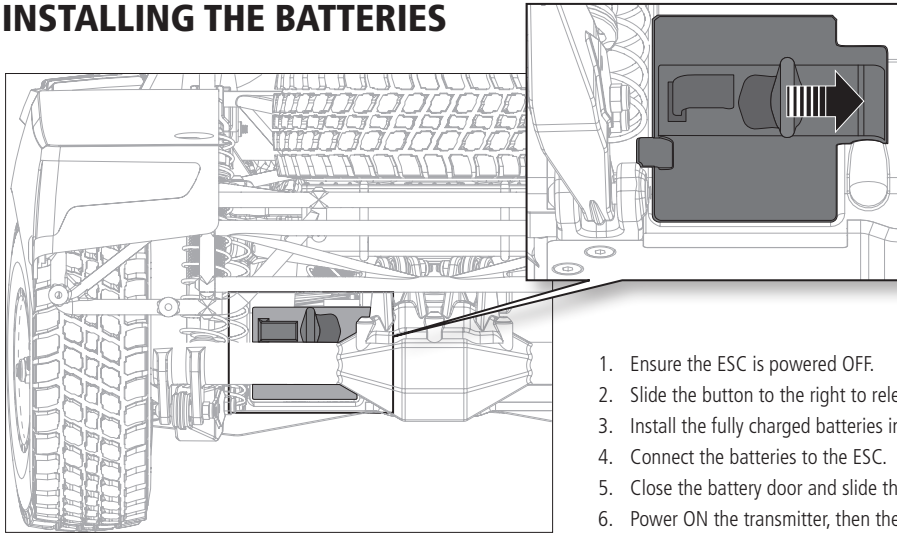

1. Ensure the ESC is powered OFF.
2. Slide the button to the right to release the battery door.
3. Install the fully charged batteries in the vehicle.
4. Connect the batteries to the ESC.
5. Close the battery door and slide the battery door button to the left to secure it.
6. Power ON the transmitter, then the vehicle.

DRIVING PRECAUTIONS

- Maintain sight of the vehicle at all times.
- Routinely inspect the vehicle for loose wheel hardware.
- Routinely inspect the steering assembly for any loose hardware. Driving the vehicle off-road can cause fasteners to loosen over time.
- Do not drive the vehicle in tall grass. Doing so can damage the vehicle or electronics.
- Stop driving the vehicle when you notice a lack of power. Driving the vehicle when the battery is discharged can cause the receiver to power off. If the receiver loses power, you will lose control of the vehicle. Damage due to an over-discharged Li-Po battery is not covered under warranty.

CAUTION: Do not discharge a Li-Po battery below 3V per cell. Batteries discharged to a voltage lower than the lowest approved voltage may become damaged, resulting in loss of performance and potential fire when batteries are charged.

- Do not apply forward or reverse throttle if the vehicle is stuck. Applying throttle in this instance can damage the motor or ESC.
- After driving the vehicle, allow the electronics to cool before driving the vehicle again.

IMPORTANT: Keep wires away from all moving parts.

BEFORE RUNNING YOUR VEHICLE

1. Check for free suspension movement. All suspension arms and steering components should move freely. Any binds will cause the vehicle to handle poorly.
2. Charge a battery pack. Always charge the battery pack as per the battery and/or charger manufacturers' instructions.
3. Set the transmitter steering trim. Follow the instructions to set the steering trim/subtrim so that the vehicle drives straight with no input to the steering.
4. Perform a Control Direction Test.

POWERING ON THE VEHICLE

1. Center the ST TRIM and TH TRIM dials on the transmitter.
2. Power on the transmitter.
3. Connect the fully charged battery packs to the ESC.
4. Power on the ESC.

IMPORTANT: The vehicle **MUST** remain on a flat, level surface and motionless for at least 5 seconds.

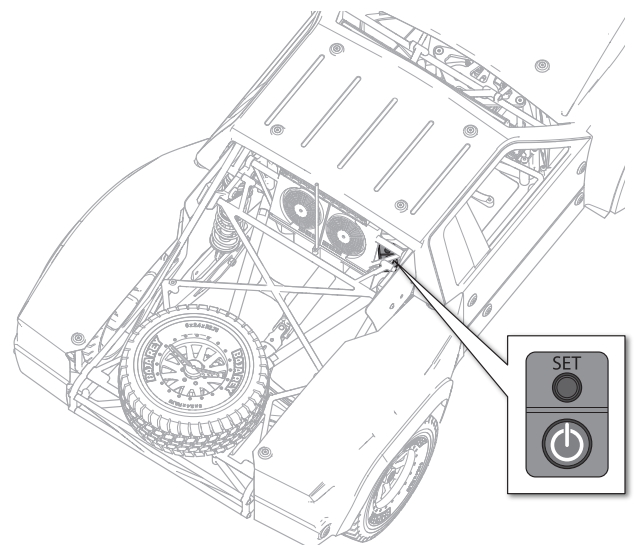

PERFORMING A CONTROL DIRECTION TEST

Perform a control test with the vehicle wheels off the ground. If the wheels rotate after the vehicle is powered ON, adjust the TH Trim knob until they stop. To make the wheels move forward, pull the trigger. To reverse them, wait for the wheels to stop, then push the trigger. When moving forward, the wheels should maintain a straight line without any steering wheel input. If not, adjust the ST Trim knob, so the wheels maintain a straight line without having to turn the steering wheel.

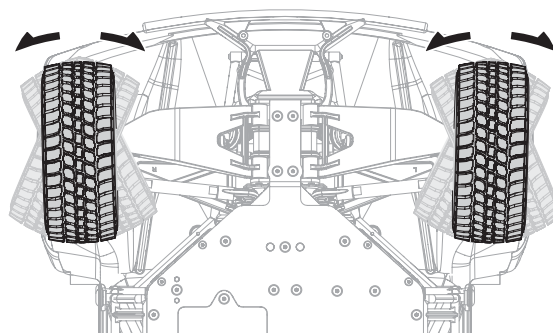

RUN TIME

The largest factor in run time is the capacity of the battery pack. A larger mAh rating increases the amount of run time experienced.

The condition of a battery pack is also an important factor in both run time and speed. The battery connectors may become hot during driving. Batteries will lose performance and capacity over time.

Driving the vehicle from a stop to full speed repeatedly will damage the batteries and electronics over time. Sudden acceleration will also lead to shorter run times.

TO IMPROVE RUN TIMES

- Keep your vehicle clean and well maintained.
- Allow more airflow to the ESC and motor.
- Change the gearing to a lower ratio. A lower ratio decreases the operating temperature of the electronics. Use a smaller pinion gear or larger spur gear to lower the gear ratio.
- Use a battery pack with a higher mAh rating.
- Use the optimum charger to charge battery packs (Visit your local hobby dealer for more information).

POWERING OFF THE VEHICLE

1. Power off the ESC.
2. Power off the transmitter.
3. Remove and charge the batteries.

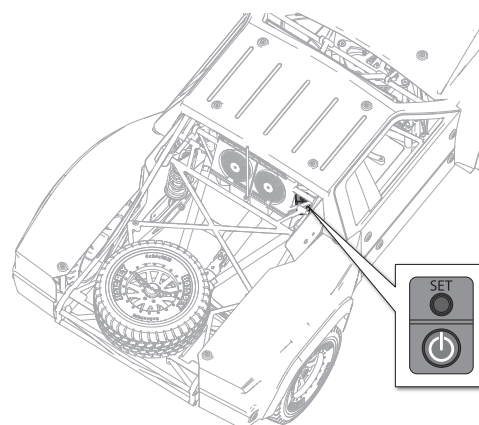

DYNAMITE® FUZE™ 1200KV BRUSHLESS MOTOR

PRECAUTIONS

- Never touch moving parts.
- Never disassemble while the batteries are installed.
- Always let parts cool before touching.

GEARING

The vehicle is equipped with the optimal gearing for the stock platform. It offers an ideal balance between speed, power and efficiency. Should you decide to customize your vehicle with optional batteries or motors, it may be necessary for you to change the pinion or spur gear.

Installing a pinion gear with fewer teeth or a spur gear with more teeth will provide greater torque but will reduce top speed. Likewise, a pinion gear with more teeth or a spur gear with fewer teeth will reduce torque and increase top speed. Care should be taken when installing larger pinion gears as this can "overgear" the vehicle, resulting in overheating of the motor and ESC. When testing different gearing options, pay close attention to the temperature of the motor and speed control to ensure you are operating within the temperature range of the components. The motor or ESC should never be so hot that it cannot be touched. If temperatures are too hot, a different gearing combination with a lower pinion gear and/or higher spur gear is suggested.

CHANGING THE PINION GEAR/GEAR RATIO

The Super Baja Rey uses a motor mount with pre-set gearing from 16-24T.

1. Remove the lower motor mount chassis plate, the motor, and motor mount.
2. Loosen the set screw and remove the installed pinion gear.
3. Install the motor screws corresponding to the number of teeth on the pinion gear.
4. Place the new pinion gear on the end of the motor shaft, so the setscrew is located over the flat of the shaft.
5. Position the pinion gear so that the teeth line up with the spur gear and secure the pinion gear by tightening the set screw.
6. Check the gear mesh to ensure that everything spins properly.

SETTING THE GEAR MESH

The motor gearing is set on the motor mount and uses corresponding holes that match the number of teeth on the pinion gear. The gear mesh has already been set at the factory. Setting it is only necessary when changing motors or gears.

Proper gear mesh (how gear teeth meet) is important to the performance of the vehicle. When the gear mesh is too loose, the pinion gear can damage the spur gear. If the mesh is too tight, speed could be limited and the motor and ESC will overheat.

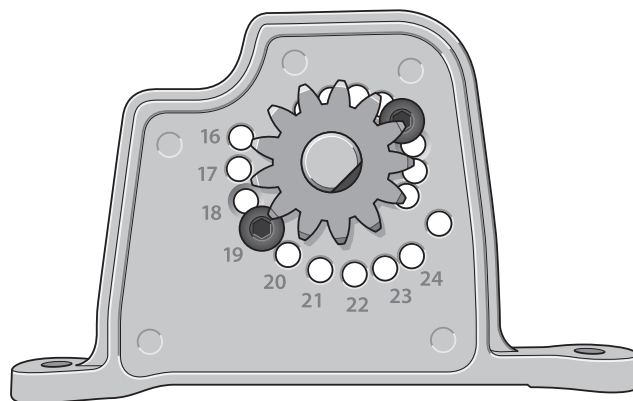

IMPORTANT: The included 19T pinion gear is suitable for use with a 6S Li-Po battery.

NOTICE: For extreme load surfaces (e.g., sand and tall grass), gear down 1–2 teeth on the pinion gear to minimize the chance of motor and ESC damage.

ESC FUNCTIONS

SPECIFICATIONS

Type	Sensorless
Constant/Peak	160A/1050A
Resistance	0.00020hm
Function	Forward with Brake, Forward/Reverse with Brake
Operation	Proportional forward, proportional reverse with braking
Input Voltage	3–8s LiPo
BEC Output	6V/8.4V, 6A
Overload Protection	Motor Lock-up protection, Low-voltage cutoff protection, Thermal protection, Overload protection and fail safe (throttle signal loss protection)
Dimensions (LxWxH)	70mm x 65mm x 45.5mm
Weight	288g

ESC LED STATUS

- No ESC LEDs will glow when there is no throttle input from the transmitter.
- The red ESC LED glows when there is any throttle input from the transmitter.

AUDIBLE WARNING TONES

- Input Voltage:** The ESC checks the input voltage when it is powered ON. If a voltage problem is detected, the ESC continuously sounds 2 beeps with a 1 second pause (xx-xx-xx). Power OFF the ESC and ensure the connections are secure and that the battery power is not too low for safe operation.
- Radio Connection:** The ESC checks radio signal input when it is powered ON. If a problem is detected, the ESC continuously sounds 1 beep with a 2 second pause (x--x--x). Power OFF the ESC and ensure the radio system is operating correctly.

The black-shaded setting is the factory default.

PROGRAMMABLE ITEMS	PROGRAMMABLE VALUE								
	1	2	3	4	5	6	7	8	9
1 Running Mode	Forward with Brake	Forward/ Reverse with Brake							
2 Li-Po Cells	Auto Calc.	3s	4s	6s	8s				
3 Low Voltage Cutoff	Auto (Low)	Auto (Intermediate)	Auto (High)						
4 BEC Voltage	6.0V	8.4V							
5 Max Brake Force	25%	50%	75%	100%	Disable				
6 Max Reverse Force	25%	50%							
7 Start Mode/Punch	Level 1	Level 2	Level 3	Level 4	Level 5				
8 Timing	0°	3.75°	7.5°	11.25°	15°				

DESCRIPTIONS

1. Running Mode

- Forward Only with Brake**
Intended for competition use, this mode allows only forward and brake controls.
- Forward/Reverse with Brake**
This mode is the basic all-around mode, allowing forward, reverse and brake controls. To engage reverse while moving forward, apply the brake until the vehicle has come to a complete stop, release brake, then apply the brake again. While braking or in reverse, engaging the throttle will result in the vehicle immediately accelerating forward.

2. Li-Po Cells

The default setting is **Auto Calc.**, which will automatically select the detected number of cells. Select value 2–5 to manually select a cell count from 3–8 cells.

3. Low Voltage Cutoff

This function helps to prevent battery over-discharge. The ESC continuously monitors the battery's voltage. If the voltage falls below the voltage threshold for 2 seconds, the output power shuts off and the red LED flashes twice repeatedly.

The cutoff threshold calculation is based on individual Li-Po cell voltage. For Ni-MH batteries, if the voltage battery pack is higher than 9.0V, it will be treated as a 3-cell Li-Po battery pack; if it is lower than 9.0V, it will be treated as a 2-cell Li-Po battery pack. Example: for a 8.0V Ni-MH battery pack used with a 2.6V/cell threshold, it will be treated as a 2-cell Li-Po battery pack and the low-voltage cut-off threshold will be 5.2V (2.6x2=5.2).

ESC CALIBRATION PROCEDURE

Ensure proper ESC function by calibrating the ESC to your transmitter inputs.

- Power OFF the ESC.
- Ensure your transmitter is powered ON, the throttle is not reversed, the throttle trim is neutral and the throttle travel range is at 100%. Disable any special functions such as ABS, etc.
- Press the SET button while powering ON the ESC. Release the button as soon as the red LED starts to flash.
- Calibrate the throttle points by pressing the SET button once after each step.
 - Neutral (1 flash)—leave the throttle at rest, untouched
 - Full throttle (2 flashes)—pull the throttle fully back
 - Full brake/reverse (3 flashes)—push the throttle fully forward
- The motor will run 3 seconds after the last step is completed.

Tip: If the motor turns in the wrong direction, reverse the connection of any 2 outside motor wires. The center wire must remain in the center and cannot be moved to another motor tab.



ESC PROGRAMMING PROCEDURE

- Connect a fully charged battery to the ESC.
- Power ON the ESC using the ESC switch.
- Hold the SET button for 1 second until the GREEN LED blinks, then release the SET button to enter programming mode.
- Press and release the SET button as needed to get to the desired menu option (the GREEN LED will blink corresponding to the menu item number). Programming menu items 1 through 6 are accessible using the SET button on the ESC.
- When at the desired menu item, hold the SET button for 3 seconds until the RED LED blinks.
- Press the SET button to move among the settings based on how many times the RED LED blinks (Refer to the table for more information).
- Save the setting by holding the SET button for 3 seconds.
- Power OFF the ESC switch and repeat the instructions above to change other settings.

4. Bec Voltage

Select either 6 or 8.4V to run the receiver and servos.

5. Max Brake Force

Adjusts the maximum braking force. A higher value provides stronger braking, but can also cause the wheels to lock, resulting in loss of control of the car.

6. Max Reverse Force

This parameter adjusts the maximum power when travelling in reverse.

7. Start Mode (Punch)

Sets the initial throttle punch when the car accelerates. Level 1 gives a very soft initial acceleration and level 5 gives a stronger initial acceleration.

8. Timing

Allows for timing value selection according to your motor. Generally, higher timing value brings out higher power output, but the efficiency of the system will be slightly lower with possible increases in motor and ESC running temperatures.

TROUBLESHOOTING GUIDE

PROBLEM	POSSIBLE CAUSE	SOLUTION
Vehicle does not operate	Battery not charged or plugged in	Charge battery/plug in
	ESC switch not "On"	Turn on ESC switch
	Transmitter not "On" or low battery	Turn on/replace batteries
Motor runs but wheels do not rotate	Pinion not meshing with spur gear	Adjust pinion/spur mesh
	Pinion spinning on motor shaft	Tighten pinion gear setscrew on motor shaft flat spot
	Transmission gears stripped	Replace transmission gears
	Drive pin broken	Check and replace drive pin
Steering does not work	Servo plug not in receiver properly	Make sure the steering servo plug is connected to the receiver steering channel, noting proper polarity
	Servo gears or motor damaged	Replace or repair servo
Will not turn one direction	Servo gears damaged	Replace or repair servo
Motor does not run	Motor wires not connected properly	Check bullet connectors for proper fit
	Motor wire broken	Repair or replace as needed
	ESC damaged	Contact Horizon Hobby Product Support
ESC gets hot	Motor over-gear	Use smaller pinion or larger spur gear
	Driveline bound up	Check wheels and transmission for binding
Poor run time and/or sluggish acceleration	Battery pack not fully charged	Recharge battery
	Charger not allowing full charge	Try another charger
	Driveline bound up	Check wheels, transmission for binding
Poor range and/or glitching	Transmitter batteries low	Check and replace
	Vehicle battery low	Recharge battery
	Loose plugs or wires	Check all wire connections and plugs

LIMITED WARRANTY

What this Warranty Covers

Horizon Hobby, LLC, (Horizon) warrants to the original purchaser that the product purchased (the "Product") will be free from defects in materials and workmanship at the date of purchase.

What is Not Covered

This warranty is not transferable and does not cover (i) cosmetic damage, (ii) damage due to acts of God, accident, misuse, abuse, negligence, commercial use, or due to improper use, installation, operation or maintenance, (iii) modification of or to any part of the Product, (iv) attempted service by anyone other than a Horizon Hobby authorized service center, (v) Product not purchased from an authorized Horizon dealer, or (vi) Product not compliant with applicable technical regulations or (vii) use that violates any applicable laws, rules, or regulations. OTHER THAN THE EXPRESS WARRANTY ABOVE, HORIZON MAKES NO OTHER WARRANTY OR REPRESENTATION, AND HEREBY DISCLAIMS ANY AND ALL IMPLIED WARRANTIES, INCLUDING, WITHOUT LIMITATION, THE IMPLIED WARRANTIES OF NON-INFRINGEMENT, MERCHANTABILITY AND FITNESS FOR A PARTICULAR PURPOSE. THE PURCHASER ACKNOWLEDGES THAT THEY ALONE HAVE DETERMINED THAT THE PRODUCT WILL SUITABLY MEET THE REQUIREMENTS OF THE PURCHASER'S INTENDED USE.

Purchaser's Remedy

Horizon's sole obligation and purchaser's sole and exclusive remedy shall be that Horizon will, at its option, either (i) service, or (ii) replace, any Product determined by Horizon to be defective. Horizon reserves the right to inspect any and all Product(s) involved in a warranty claim. Service or replacement decisions are at the sole discretion of Horizon. Proof of purchase is required for all warranty claims. SERVICE OR REPLACEMENT AS PROVIDED UNDER THIS WARRANTY IS THE PURCHASER'S SOLE AND EXCLUSIVE REMEDY.

Limitation of Liability

HORIZON SHALL NOT BE LIABLE FOR SPECIAL, INDIRECT, INCIDENTAL OR CONSEQUENTIAL DAMAGES, LOSS OF PROFITS OR PRODUCTION OR COMMERCIAL LOSS IN ANY WAY, REGARDLESS OF WHETHER SUCH CLAIM IS BASED IN CONTRACT, WARRANTY, TORT, NEGLIGENCE, STRICT LIABILITY OR ANY OTHER THEORY OF LIABILITY, EVEN IF HORIZON HAS BEEN ADVISED OF THE POSSIBILITY OF SUCH DAMAGES. Further, in no event shall the liability of Horizon exceed the individual price of the Product on which liability is asserted. As Horizon has no control over use, setup, final assembly, modification or misuse, no liability shall be assumed nor accepted for any resulting damage or injury. By the act of use, setup or assembly, the user accepts all resulting liability. If you as the purchaser or user are not prepared to accept the liability associated with the use of the Product, purchaser is advised to return the Product immediately in new and unused condition to the place of purchase.

Law

These terms are governed by Illinois law (without regard to conflict of law principals). This warranty gives you specific legal rights, and you may also have other rights which vary from state to state. Horizon reserves the right to change or modify this warranty at any time without notice.

WARRANTY SERVICES

Questions, Assistance, and Services

Your local hobby store and/or place of purchase cannot provide warranty support or service. Once assembly, setup or use of the Product has been started, you must contact your local distributor or Horizon directly. This will enable Horizon to better answer your questions and service you in the event that you may need any assistance. For questions or assistance, please

visit our website at www.horizonhobby.com, submit a Product Support Inquiry, or call the toll free telephone number referenced in the Warranty and Service Contact Information section to speak with a Product Support representative.

Inspection or Services

If this Product needs to be inspected or serviced and is compliant in the country you live and use the Product in, please use the Horizon Online Service Request submission process found on our website or call Horizon to obtain a Return Merchandise Authorization (RMA) number. Pack the Product securely using a shipping carton. Please note that original boxes may be included, but are not designed to withstand the rigors of shipping without additional protection. Ship via a carrier that provides tracking and insurance for lost or damaged parcels, as Horizon is not responsible for merchandise until it arrives and is accepted at our facility. An Online Service Request is available at http://www.horizonhobby.com/content/_service-center_render-service-center. If you do not have internet access, please contact Horizon Product Support to obtain a RMA number along with instructions for submitting your product for service. When calling Horizon, you will be asked to provide your complete name, street address, email address and phone number where you can be reached during business hours. When sending product into Horizon, please include your RMA number, a list of the included items, and a brief summary of the problem. A copy of your original sales receipt must be included for warranty consideration. Be sure your name, address, and RMA number are clearly written on the outside of the shipping carton.

NOTICE: Do not ship Li-Po batteries to Horizon. If you have any issue with a Li-Po battery, please contact the appropriate Horizon Product Support office.

Warranty Requirements

For Warranty consideration, you must include your original sales receipt verifying the proof-of-purchase date. Provided warranty conditions have been met, your Product will be serviced or replaced free of charge. Service or replacement decisions are at the sole discretion of Horizon.

Non-Warranty Service

Should your service not be covered by warranty, service will be completed and payment will be required without notification or estimate of the expense unless the expense exceeds 50% of the retail purchase cost. By submitting the item for service you are agreeing to payment of the service without notification. Service estimates are available upon request. You must include this request with your item submitted for service. Non-warranty service estimates will be billed a minimum of ½ hour of labor. In addition you will be billed for return freight. Horizon accepts money orders and cashier's checks, as well as Visa, MasterCard, American Express, and Discover cards. By submitting any item to Horizon for service, you are agreeing to Horizon's Terms and Conditions found on our website http://www.horizonhobby.com/content/_service-center_render-service-center.

ATTENTION: Horizon service is limited to Product compliant in the country of use and ownership. If received, a non-compliant Product will not be serviced. Further, the sender will be responsible for arranging return shipment of the un-serviced Product, through a carrier of the sender's choice and at the sender's expense. Horizon will hold non-compliant Product for a period of 60 days from notification, after which it will be discarded.

Warranty and Service Contact Information

Country of Purchase	Horizon Hobby	Contact Information	Address
United States of America	Horizon Service Center (Repairs and Repair Requests)	servicecenter.horizonhobby.com/RequestForm/	2904 Research Road Champaign, Illinois 61822 USA
	Horizon Product Support (Product Technical Assistance)	productsupport@horizonhobby.com 877-504-0233	
	Sales	websales@horizonhobby.com 800-338-4639	
EU	Horizon Technischer Service	service@horizonhobby.eu +49 (0) 4121 2655 100	Hanskampring 9 D 22885 Barsbüttel, Germany
	Sales: Horizon Hobby GmbH		

FCC Statement

FCC ID: BRWDASRX12 This device complies with part 15 of the FCC rules. Operation is subject to the following two conditions: (1) this device may not cause harmful interference, and (2) this device must accept any interference received, including interference that may cause undesired operation.

 **CAUTION:** Changes or modifications not expressly approved by the party responsible for compliance could void the user's authority to operate the equipment.

This product contains a radio transmitter with wireless technology which has been tested and found to be compliant with the applicable regulations governing a radio transmitter in the 2.400GHz to 2.4835GHz frequency range.

 **Supplier's Declaration of Conformity**
LOS Super Baja Rey BND
LOS05018

This device complies with part 15 of the FCC Rules. Operation is subject to the following two conditions: (1) This device may not cause harmful interference, and (2) this device must accept any interference received, including interference that may cause undesired operation.

 **CAUTION:** changes or modifications not expressly approved by the party responsible for compliance could void the user's authority to operate the equipment.

NOTE: This equipment has been tested and found to comply with the limits for a Class B digital device, pursuant to part 15 of the FCC Rules. These limits are designed to provide reasonable

protection against harmful interference in a residential installation. This equipment generates, uses and can radiate radio frequency energy and, if not installed and used in accordance with the instructions, may cause harmful interference to radio communications. However, there is no guarantee that interference will not occur in a particular installation. If this equipment does cause harmful interference to radio or television reception, which can be determined by turning the equipment off and on, the user is encouraged to try to correct the interference by one or more of the following measures:

- Reorient or relocate the receiving antenna.
- Increase the separation between the equipment and receiver.
- Connect the equipment into an outlet on a circuit different from that to which the receiver is connected.
- Consult the dealer or an experienced radio/TV technician for help.

Horizon Hobby, LLC
4105 Fieldstone Rd.,
Champaign, IL 61822
Email: compliance@horizonhobby.com
Web: HorizonHobby.com

IC Information

IC: CAN ICES-3 (B)/NMB-3(B) | 6157A-AMRX12 This device complies with Industry Canada licence-exempt RSS standard(s). Operation is subject to the following two conditions: (1) this device may not cause interference, and (2) this device must accept any interference, including interference that may cause undesired operation of the device.

 **EU Compliance Statement:** Horizon Hobby, LLC hereby declares that this product is in compliance with the essential requirements and other relevant provisions of the RED and EMC Directives.

A copy of the EU Declaration of Conformity is available online at:
<http://www.horizonhobby.com/content/support-render-compliance>.



Instructions for disposal of WEEE by users in the European Union

This product must not be disposed of with other waste. Instead, it is the user's responsibility to dispose of their waste equipment by handing it over to a designated collections point for the recycling of waste electrical and electronic equipment. The separate collection and recycling of your waste equipment at the time of disposal will help to conserve natural resources and ensure that it is recycled in a manner that protects human health and the environment. For more information about where you can drop off your waste equipment for recycling, please contact your local city office, your household waste disposal service or where you purchased the product.

Replacement Parts // Teileliste // Liste des pièces de rechange // Elenco dei ricambi

Part #	English	Deutsch	Français	Italiano
DYNS1660	Fuze 1/6th BL Motor 1200kv	Fuze 1/6th BL Motor 1200kv	Moteur Fuze 1200 kV BL 4P 1/6	Motore Fuze 1/6 denti BL 1200Kv
DYNS2661	Fuze 160A BL WP 1/5th ESC	Zünder 160A BL WP 1/5-Maßstab ESC	ESC Fuze 160 A BL WP 1/5	ESC Fuze 160A BL WP 1/5 denti
LOS235007	Button Head Screw M3 x 12 mm (10)	Rundkopfschraube, M3 x 12 mm (10)	Vis à tête bombée, M3 x 12 mm (10)	Vite a testa tonda M3 x 12 mm (10)
LOS235009	Flat Head Screw M2,5 x 8 mm (10)	Flachkopfschraube M2,5 x 8 mm (10)	Vis à tête plate, M2,5 x 8 mm (10)	Vite a testa piana M2,5 x 8 mm (10)
LOS235012	Set Screw M4 x 4 mm Cup Point (10)	Stellschraube, M4 x 4mm Ringschneide (10)	Vis de fixation, bout civette, M4 x 4 mm (10)	Vite di fermo M4 x 4 mm punta a tazza (10)
LOS235025	Button Head Screw M3 x 30 mm (10)	Rundkopfschraube, M3 x 30 mm (10)	Vis à tête bombée, M3 x 30 mm (10)	Vite a testa tonda M3 x 30 mm (10)
LOS236001	3.2 mm x 7 mm x .5 mm Washer (10)	3,2 mm x 7mm x 0,5 mm Unterlegscheibe (10)	Rondelle 3,2 mm x 7 mm x 5 mm (10)	Rondella 3,2 mm x 7 mm x 0,5 mm (10)
LOS250022	Body Button Base and Top (22)	Body Button unten und oben (22)	Bouton corps haut et bas (22)	Base e parte superiore bottone carrozzeria (22)
LOS250023	Interior Set w/ Helmets, Clear	Interieurset mit Helmen, Transparent	Lot intérieur avec casques, clair	Serie interni con caschi, trasparente
LOS250024	Brake and Spare Tire Accessory Set	Bremse und Ersatzreifen Zubehörset	Ensemble d'accessoires pour pneus de secours et freins	Serie accessori freno e pneumatico di riserva
LOS250032	Cab Section, Black/White/Orange	Baldachinabschnitt, Black/White/Orange	Section cabine, Black/White/Orange	Sezione abitacolo, Black/White/Orange
LOS250033	Front Hood, Black/White/Orange	Frontklappe, Schwarz/Weiß/Orange	Capot avant, Schwarz/ Weiß/Orange	Cofano anteriore, Schwarz/ Weiß/Orange
LOS250034	L/R Rear Fender Set, Black/White/Orange	L/R Heck Schutzblechset, Schwarz/ Weiß/Orange	Lot de protections arrières D/G, noir/ blanc/orange	Serie parafanghi anteriori sinistro/destro, ner/ bianca/ arancia
LOS251054	Roll Cage Sides (L&R)	Überrollkäfigseiten (L&R)	Cage de retournement, côtés, D/G	Lati scocca di protezione (Sinistro e destro)
LOS251055	Rear Body Mount Bar (L&R) X-Bar	Hintere Gehäusehalterungsstange (L&R) X-Balken	Crossbar, barre de montage (G/D), corps arrière	Barra supporto carrozzeria posteriore (Sinistra e destra), Barra Trasversale
LOS251056	Rear Bulkhead, Fan Panel, Mud Guards	Hintere Spritzwand, Lüfterplatte, Schmutzfänger	Cloison arrière, panneau ventilation, garde-boue	Paratia posteriore, pannello ventola, parafanghi
LOS251057	Front Bumper & Skid Plate	Frontstoßstange und Gleitbrett	Pare-choc avant et plaque de protection	Paraurti anteriore e piastra protezione
LOS251058	Battery Tray, Door, Lock, EC5 Base Set	Akkualterung, Tür, Schloss, EC5-Basis-Set	Support de batterie, porte, verrou, ensemble de base EC5	Vassoio portabatterie, sportello, blocco, serie base EC5
LOS251059	Steering Servo Mount & Bellcrank Set	Lenkervo-Halterung & Umlenkhebelset	Support de servo de direction et ensemble levier	Supporto servocomandi sterzo e serie leve a gomito
LOS251060	Rear Chassis Brace/ESC Mount	Hintere Karosseriestrebe/ Geschwindigkeitsreglerhalterung	Renfort châssis arrière/support variateur ESC	Sostegno anteriore telaio/Supporto ESC
LOS251061	Chassis & Motor Cover Plate	Karosserie & Motorabdeckplatte	Plaque de couvercle châssis et moteur	Piastra copertura telaio e motore
LOS251062	Center Chassis Brace & Stand Offs	Zentrale Karosseriestrebe & Standoffs	Renfort châssis central et douilles	Sostegno e supporti centrali telaio
LOS251063	LED Light Bar Front	LED-Lichtstange Front	Barre d'éclairage à DEL avant	Barra anteriore luci LED
LOS251064	LED Light Bar Rear	LED-Lichtstange Heck	Barre d'éclairage à DEL arrière	Barra posteriore luci LED
LOS251065	Steering Hardware Set	Hardwaresatz Lenkung	Ensemble de matériel de direction	Set bulloneria sterzo
LOS251066	Steering Servo Arm, 15T Spline	Servolenkarm, 15T Verzahnung	Bras du servo de direction, cannelure 15T	Braccio servocomandi sterzo, scanalatura 15 denti
LOS251067	Steering Tie Rods (2)	Lenkung Zuganker (2)	Biellettes de direction (2)	Tiranti sterzo (2)
LOS251068	Foam Seal & Spacer Set	Schaumdichtung & Distanzstückset	Lot mousse d'étanchéité et entretoises	Serie sigillanti in materiale espanso e spessori
LOS251069	Roll Cage Top Bar, Front Bar	Obere Stange des Überrollkäfigs, Vorderstange	Cage de retournement, barre supérieure, barre avant	Barra superiore, barra anteriore scocca di protezione
LOS252039	Pinion Gear, 16T, Mod 1.5	Zahnradgetriebe, 16T, Mod 1,5	Engrenage à pignons, 16R, 1,5 M	Ingranaggio pignone, 16 denti, mod. 1,5
LOS252040	Pinion Gear 17T, Mod 1.5	Zahnradgetriebe, 17T, Mod 1,5	Engrenage à pignons, 17T, 1,5 M	Ingranaggio pignone, 17 denti, mod. 1,5
LOS252041	Pinion Gear, 18T, Mod 1.5	Zahnradgetriebe, 18T, Mod 1,5	Engrenage à pignons, 18T, 1,5 M	Ingranaggio pignone, 18 denti, mod. 1,5
LOS252043	Pinion Gear, 20T, Mod 1.5	Zahnradgetriebe, 20T, Mod 1,5	Engrenage à pignons, 20T, 1,5 M	Ingranaggio pignone, 20 denti, mod. 1,5
LOS252044	Pinion Gear, 21T, Mod 1.5	Zahnradgetriebe, 21T, Mod 1,5	Engrenage à pignons, 21T, 1,5 M	Ingranaggio pignone, 21 denti, mod. 1,5
LOS252045	Pinion Gear, 22T, Mod 1.5	Zahnradgetriebe, 22T, Mod 1,5	Engrenage à pignons, 22T, 1,5 M	Ingranaggio pignone, 22 denti, mod. 1,5
LOS252069	Diff Housing & Gasket	Differentialgetriebe-Gehäuse & Dichtung	Boîtier différentiel et joint	Alloggiamento e guarnizione differenziale
LOS252070	Differential Rebuild Kit	Differentialgetriebe-Umbau-Kit	Kit de reconstruction du différentiel	Kit riparazione differenziale
LOS252071	Axle Housing Set, Rear	Achsgehäuse-Set, Heck	Lot de carte d'essieu, arrière	Serie alloggiamento dell'assale, posteriore
LOS252072	Rear Driveshaft Set	Heck Antriebswelle-Set	Lot d'arbre d'entraînement arrière	Serie posteriore albero di trasmissione
LOS252073	Center Transmission Housing	Zentrales Getriebegehäuse	Boîtier de transmission centrale	Alloggiamento centrale trasmissione
LOS252074	Front Gear Box/Bulkhead	Front Getriebekasten/Spritzwand	Réducteur avant/Cloison	Scatola del cambio anteriore/Paratia
LOS252075	38T Ring & 12T Pinion Gear FR/RR	38T Ring & 12T Zahnradgetriebe FR/RR	Bague 38T et engrenage à pignons 12T AV/AR	Anello 38 denti e ingranaggio pignone 12 denti FR/RR
LOS252076	Outdrive Set FR/RR (2)	Antrieb-Set FR/RR (2)	Ensemble sortie AV/AR (2)	Serie gruppo di trasmissione FR/RR (2)
LOS252077	20 mm Wheel Hexes and Pins, Black (4)	20 mm Rad Sechskante und Bolzen, Schwarz (4)	Hexagones de roue et broches 20 mm, noir (4)	Dadi esagonali e perni ruota 20 mm, neri (4)
LOS252078	Wheel Nut, Black (4)	Radmutter, Schwarz (4)	Écrou de roue, noir (4)	Dado ruota, nero (4)
LOS252079	Pinion Gear, 19T, 1.5M, 8mm Shaft	Zahnradgetriebe, 19T, 1,5M, 8mm Welle	Engrenage à pignons, arbre de 19T, 1,5 M, 8 mm	Pignone, 19 denti, 1,5M, albero da 8mm
LOS252080	Center Transmission Gear Set	Zentrales Übersetzungsgetriebe-Set	Lot de transmission centrale	Serie centrale ingranaggi trasmissione
LOS252081	Stub Axle, Rear (2)	Achswellenstumpf, Heck (2)	Porte-fusée, arrière (2)	Fusello di ruota, posteriore (2)
LOS252082	Dogbone, Rear Axle (2)	Dogbones, Hinterachse (2)	Cardans à boules goupillées, essieu arrière (2)	Cardano spinato (dogbone), assale posteriore (2)
LOS252083	Motor Mount	Motorhalterung	Support moteur	Supporto motore
LOS252084	Center Drive Shaft, Front	Zentrales Antriebswelle, Front	Arbre d'entraînement central, avant	Albero di trasmissione centrale, anteriore
LOS252085	Front Axle Set (2)	Vorderachsenset (2)	Lot d'essieu avant (2)	Serie assali anteriori (2)
LOS252086	Diff Locker	Differentialgetriebefach	Verrouillage différentiel	Dispositivo di blocco del differenziale
LOS252087	Center Diff Outdrive Set (2)	Zentrales Differentialantrieb-Set (2)	Lot de sortie de différentiel centrale (2)	Serie gruppo di trasmissione centrale (2)
LOS254033	Shock Rebuild Kit (4)	Stoßdämpfer-Umbau-Kit (4)	Kit de reconstruction amortisseurs (4)	Kit riparazione ammortizzatore (4)
LOS254034	Shock & Rod Ends, Spring Cups (12)	Stoßdämpfer- und Gelenkköpfe, Federteller (12)	Amortisseur et embouts de bielle, cuvettes de ressort (12)	Ammortizzatore ed estremità aste, coppe a molla (12)
LOS254035	Shock Pistons	Stoßdämpferkolben	Pistons amortisseurs	Piston ammortizzatori
LOS254036	Trailing Arms (2)	Hinterachsträger (2)	Bras oscillants (2)	Bracci longitudinali (2)
LOS254037	Front Suspension Arm Set Upper/Lower (L&R)	Front Querlenker-Set Oberer/Unterer (L&R)	Bras de suspension avant configuration élevée/basse (G/D)	Serie braccetti sospensione anteriore Superiore/Inferiore (sinistro e destro)
LOS254038	Front Spindle Set (L&R)	Front Spindelsatz (L&R)	Lot de fusées avant (G/D)	Serie fuso anteriore (L&R)
LOS254039	Upper Arm/Shock Mount, Front	Oberer Arm/Stoßdämpferhalterung, Front	Bras supérieur/support amortisseurs, avant	Braccetto superiore/supporto ammortizzatore, anteriore

Replacement Parts // Teileliste // Liste des pièces de rechange // Elenco dei ricambi

Part #	English	Deutsch	Français	Italiano
LOS254040	ShockTower, Upper/Lower Track Rod Mount	Stoßdämpferbrücke, obere/untere Spurstange-Halterung	Support d'amortisseurs, support tige de renfort élevé/bas	Torre ammortizzatore, supporto asta tracciato superiore/inferiore
LOS254041	Shock Body & Collar Set, Front (2)	Stoßdämpfergehäuse & Hülsenset, Front (2)	Corps antichoc et ensemble bagues, avant (2)	Serie collare e corpo ammortizzatore, anteriore (2)
LOS254042	Shock Body & Collar Set, Rear (2)	Stoßdämpfergehäuse & Hülsenset, Heck (2)	Corps antichoc et ensemble bagues, arrière (2)	Serie collare e corpo ammortizzatore, posteriore (2)
LOS254043	Front & Rear Sway Bar Set	Front & Heck Schwingen-Set	Lot de barre stabilisatrice avant et arrière	Serie barre stabilizzatrici anteriore e posteriore
LOS254044	Shock Shaft, Front (2)	Kolbenstange, Front (2)	Butées de suspension avant (2)	Albero ammortizzatore, anteriore (2)
LOS254045	Shock Shaft, Rear (2)	Kolbenstange, Heck (2)	Butées de suspension arrière (2)	Albero ammortizzatore, posteriore (2)
LOS254046	Front Spring, Med, Silver (2)	Frontfeder, Med, Silber (2)	Ressort avant, moy, argent (2)	Molla anteriore, media, argento (2)
LOS254047	Rear Spring, Med, Silver (2)	Heckfeder, Med, Silber (2)	Ressort arrière, moy, argent (2)	Molla posteriore, media, argento (2)
LOS254048	Front Hinge Pin and Brace Set	Front Scharnierstift und Klammersatz	Lot d'axes de charnière avant	Set piastrine e perni cerniere anteriore
LOS254049	Upper Trailing Arm Links (2)	Oberer Flügelarmverbindung (2)	Liaisons bras oscillant supérieur (2)	Collegamenti bracci longitudinali superiori (2)
LOS254050	Shock Stand Off, Front (2)	Stoßdämpfer-Standoff, Front (2)	Butées de douilles, avant (2)	Distanziatore ammortizzatore, anteriore (2)
LOS254051	Pivot Ball Set	Schwenkugel-Set	Lot billes pivot	Serie sfere perno
LOS254052	Hinge Pin Screw, Outer (4)	Scharnierbolzenschraube, äußere (4)	Vis de charnière, sortie (4)	Vite perno cerniera, esterna (4)
LOS255009	Cap Head Screw, Stl, BO, M3 x 16 mm (10)	Inbusschraube, Stl, BO, M3 x 16 mm (10)	Vis d'assemblage creuse, stl, BO, M3 x 16 mm (10)	Vite a testa cilindrica, acciaio, BO, M3 x 16 mm (10)
LOS255011	Button Head Screw, Stl, BO, M4 x 30 mm (10)	Rundkopfschraube, Stl, BO, M4 x 30 mm (10)	Vis à tête bombée, stl, BO, M4 x 30 mm (10)	Vite a testa tonda, acciaio, BO, M4 x 30 mm (10)
LOS255012	Button Head Screw, Stl, BO, M4 x 35 mm (10)	Rundkopfschraube, Stl, BO, M4 x 35 mm (10)	Vis à tête bombée, stl, BO, M4 x 35 mm (10)	Vite a testa tonda, acciaio, BO, M4 x 35 mm (10)
LOS255013	Button Head Screw, Stl, BO, M4 x 65 mm (10)	Rundkopfschraube, Stl, BO, M4 x 65 mm (10)	Vis à tête bombée, stl, BO, M4 x 65 mm (10)	Vite a testa tonda, acciaio, BO, M4 x 65 mm (10)
LOS255014	Button Head Screw, Stl, BO, M4 x 14 mm (10)	Rundkopfschraube, Stl, BO, M4 x 14 mm (10)	Vis à tête bombée, stl, BO, M4 x 14 mm (10)	Vite a testa tonda, acciaio, BO, M4 x 14 mm (10)
LOS255016	Flat Head Screw, Stl, BO, M4 x 10 mm (10)	Flachkopfschraube, Stl, BO, M4 x 10 mm (10)	Vis à tête plate, stl, BO, M4 x 10 mm (10)	Vite a testa piana, acciaio, BO, M4 x 10 mm (10)
LOS255017	Flat Head Screw, Stl, BO, M4 x 16 mm (10)	Flachkopfschraube, Stl, BO, M4 x 16 mm (10)	Vis à tête plate, stl, BO, M4 x 16 mm (10)	Vite a testa piana, acciaio, BO, M4 x 16 mm (10)
LOS255018	Flat Head Screw, Stl, BO, M4 x 25 mm (10)	Flachkopfschraube, Stl, BO, M4 x 25 mm (10)	Vis à tête plate, stl, BO, M4 x 25 mm (10)	Vite a testa piana, acciaio, BO, M4 x 25 mm (10)
LOS255019	Flat Head Screw, Stl, BO, M4 x 14 mm (10)	Flachkopfschraube, Stl, BO, M4 x 14 mm (10)	Vis à tête plate, stl, BO, M4 x 14 mm (10)	Vite a testa piana, acciaio, BO, M4 x 14 mm (10)
LOS255020	Flat Head Screw, Stl, BO, M4 x 18 mm (10)	Flachkopfschraube, Stl, BO, M4 x 18 mm (10)	Vis à tête plate, stl, BO, M4 x 18 mm (10)	Vite a testa piana, acciaio, BO, M4 x 18 mm (10)
LOS255021	Set Screw, Stl, BO, Flat Point, M4 x 6 mm (10)	Stellschraube, Stl, BO, Flat Point, M4 x 6 mm (10)	Vis de fixation, stl, BO, bout plat, M4 x 6 mm (10)	Vite di fermo, acciaio, BO, punta piana, M4 x 6 mm (10)
LOS255022	Set Screw, Stl, BO, Flat Point, M5 x 30 mm (10)	Stellschraube, Stl, BO, Flat Point, M5 x 30 mm (10)	Vis de fixation, stl, BO, bout plat, M5 x 30 mm (10)	Vite di fermo, acciaio, BO, punta piana, M5 x 30 mm (10)
LOS255024	Flat Nut, Stl, M4 (10)	Flache Mutter, Stl, M4 (10)	Écrou plat, stl, M4 (10)	Dado piano, acciaio, M4 (10)
LOS257006	10 x 19 x 5 mm Ball Bearing (2)	10 x 19 x 5 mm Kugellager (2)	Roulement à billes 10 x 19 x 5 mm (2)	Cuscinetto a sfera 10 x 19 x 5 mm (2)
LOS257007	4 x 8 x 3mm Ball Bearing (4)	4 x 8 x 3mm Kugellager (4)	Roulement à billes 4 x 8 x 3 mm (4)	Cuscinetto a sfera 4 x 8 x 3mm (4)
LOS45019	Desert Claw Tire with Foam (2)	Desert Claw-Reifen mit Schaumstoff (2)	Pneu Desert Claw avec mousse (2)	Pneumatico Desert Claw con materiale espanso (2)
LOS45020	Wheels, Silver (2)	Räder, Silber (2)	Roues, argent (2)	Ruote, argento (2)
LOSA6942	8 x 16 mm Sealed Ball Bearing (4)	8 x 16 mm abgedichtetes Kugellager (4)	Roulement à billes hermétique 8 x 16 mm (4)	Cuscinetto a sfera sigillato 8 x 16 mm (4)
SPM2335	DX2E Active 2-CH DSMR Radio w/ SR310	DX2E Aktives 2-Kanal DSMR Funkgerät mit SR310	Radio DX2E Active 2 canaux DSMR avec SR310	Radiocomando DX2E Active 2 canali DSMR con SR310
SPMS904	S904 1/6 Scale WP Digital Servo	S904 1/6 Maßstab WP Digitaler Servo	Servo numérique WP à l'échelle 1/6 S904	Servocomando digitale S904 scala 1/6 WP
SPMSR56000	SRS6000 DSMR AVC Surface Rx	SRS6000 DSMR AVC Oberflächenempfänger	SRS6000 DSMR AVC Surface Rx	Ricevitore di superficie SRS6000 DSMR AVC
TLR255003	Cap Head Screw, M2,5 x 6 mm (10)	Inbusschraube, M2,5 x 6 mm (10)	Vis d'assemblage creuse, M2,5 x 6 mm (10)	Vite a testa cilindrica M2,5 x 6 mm (10)
TLR255008	Button Head Screw, M4 x 16 mm (10)	Rundkopfschraube, M4 x 16 mm (10)	Vis à tête bombée, M4 x 16 mm (10)	Vite a testa tonda M4 x 16 mm (10)
TLR255009	Button Head Screw, M4 x 20 mm (10)	Rundkopfschraube, M4 x 20 mm (10)	Vis à tête bombée, M4 x 20 mm (10)	Vite a testa tonda M4 x 20 mm (10)
TLR255010	Button Head Screw, M4 x 25 mm (10)	Rundkopfschraube, M4 x 25 mm (10)	Vis à tête bombée, M4 x 25 mm (10)	Vite a testa tonda M4 x 25 mm (10)
TLR255013	Flat Head Screw, M4 x 12 mm (10)	Rundkopfschraube, M4 x 12 mm (10)	Vis à tête plate, M4 x 12 mm (10)	Vite a testa piana M4 x 12 mm (10)
TLR255014	Flat Head Screw, M4 x 20 mm (10)	Rundkopfschraube, M4 x 20 mm (10)	Vis à tête plate, M4 x 20 mm (10)	Vite a testa piana M4 x 20 mm (10)
TLR255015	Setscrew, Cup Point, M4 x 5 mm (10)	Stellschraube, Ringschneide, M4 x 5 mm (10)	Vis de fixation, bout cuvette, M4 x 5 mm (10)	Vite di fermo, a M4 x 5 mm (10)
TLR5901	Button Head Screw, M3 x 6 mm (10)	Rundkopfschraube, M3 x 6 mm (10)	Vis à tête bombée, M3 x 6 mm (10)	Vite a testa tonda M3 x 6 mm (10)
TLR5902	Button Head Screw, M3 x 8 mm (10)	Rundkopfschraube, M3 x 8 mm (10)	Vis à tête bombée, M3 x 8 mm (10)	Vite a testa tonda M3 x 8 mm (10)
TLR5903	Button Head Screw, M3 x 10 mm (10)	Rundkopfschraube, M3 x 10 mm (10)	Vis à tête bombée, M3 x 10 mm (10)	Vite a testa tonda M3 x 10 mm (10)
TLR5904	Button Head Screw, M3 x 12 mm (10)	Rundkopfschraube, M3 x 12 mm (10)	Vis à tête bombée, M3 x 12 mm (10)	Vite a testa tonda M3 x 12 mm (10)
TLR5906	Button Head Screw, M3 x 35 mm (10)	Rundkopfschraube, M3 x 35 mm (10)	Vis à tête bombée, M3 x 35 mm (10)	Vite a testa tonda M3 x 35 mm (10)
TLR5909	Button Head Screw, M3x16 mm (10)	Rundkopfschraube, M3 x 16 mm (10)	Vis à tête bombée, M3 x 16 mm (10)	Vite a testa tonda, M3x16 (10)
TLR5911	Button Head Screw, M3 x 20 mm (10)	Rundkopfschraube, M3 x 20 mm (10)	Vis à tête bombée, M3 x 20 mm (10)	Vite a testa tonda, M3 x 20 mm (10)
TLR5932	Cap Head Screw, M3 x 10 mm (10)	Inbusschraube, M3 x 10 mm (10)	Vis d'assemblage creuse, M3 x 10 mm (10)	Vite a testa cilindrica M3 x 10 mm (10)
TLR5933	Cap Head Screw, M3 x 12 mm (10)	Inbusschraube, M3 x 12 mm (10)	Vis d'assemblage creuse, M3 x 12 mm (10)	Vite a testa cilindrica M3 x 12 mm (10)
TLR5963	Flathead Screw, M3 x 12 mm (10)	Flachkopfschraube, M3 x 12 mm (10)	Vis à tête plate, M3 x 12 mm (10)	Vite a testa piana, M3 x 12 mm (10)
TLR5964	Flathead Screw, M3 x 16 mm (10)	Flachkopfschraube, M3 x 16 mm (10)	Vis à tête plate, M3 x 16 mm (10)	Vite a testa piana, M3 x 16 mm (10)
TLR6289	Set Screw, M3 x 5 mm (10)	Stellschraube, M3 x 5 mm (10)	Vis de fixation, M3 x 5 mm (10)	Vite di fermo, M3 x 5 mm (10)
VTR235005	M2 x 10 mm Cap Head Screw (10)	M2 x 10 mm Inbusschraube (10)	Vis d'assemblage creuse, M2 x 10 mm (10)	Vite testa cilindrica M2 x 10 mm (10)
VTR236044	M5 Nylock Flanged Serrated Nut (10)	M5 Nylock gezahnte Flanschmutter (10)	Écrou dentelé bridé Nylock M5 (10)	Dado autobloccante flangiato dentellato M5 (10)
VTR236078	4.3 mm x 9 mm x 0.8 mm Washer (10)	4,3 mm x 7mmx 0,8 mm Unterlegscheibe (10)	Rondelle 4,3 mm x 9 mm x 0,8 mm (10)	Rondella 4,3 mm x 9 mm x 0,8 mm (10)
DYNB3810EC	7.4V 5000mAh 2550C LiPo, Hardcase: EC5	7,4 V 5000 mAh 2550C LiPo, Hartschale: EC5	Li-Po 7,4 V 5000 mAh, 25, 50C, coffret : EC5	Batteria Li-Po 7,4 V 5000mAh 2550C, custodia rigida: EC5
DYNB3811EC	11.1V 5000mAh 3550C LiPo, Hardcase	11,1 V 5000 mAh 3550C LiPo, Hartschale	Li-Po 11,1 V 5000 mAh, 35, 50C, coffret	Batteria Li-Po 11,1 V 5000mAh 3550C, custodia rigida
DYNB3855EC	HD7.6V 5000mAh 2550C LiPo Case	7,6 V 5000 mAh 2550C LiPo Schale	Boîtier Li-Po 7,6 V 5000 mAh, 25, 50C	Batteria Li-Po HD7,6 V 5000mAh 2550C, custodia
DYNB3856EC	HD11.4V 5000mAh 3S 50C LiPo Case	HD11.4V 5000mAh 3S 50C LiPo Schale	Boîtier Li-Po HD 11,4 V 5000 mAh 3S 50C	Batteria Li-Po HD11,4 V 5000mAh 3S 50C, custodia
DYNC3005	Passport 400W Dual ACDC Touch	Dynamite Passport 400W Dual ACDC Touch	Passport 400 W Dual CA/CC Touch	Caricabatterie con touch-screen doppia alimentazione CA/CC Passport 400W
DYNC3010	UltraForce 220W Touch Charger	UltraForce 220W Touch-Akkuladegerät	UltraForce 220 W Touch Charger	Caricabatterie con touch-screen UltraForce 220W

Optional Parts // Diverse Teile // Pièces optionnelles // Pezzi opzionali

Part #	English	Deutsch	Français	Italiano
LOS350002	Cab Section, Clear	Baldachinabschnitt, Transparent	Section cabine, clair	Sezione abitacolo, trasparente
LOS350003	Front Hood, Clear	Frontklappe, Transparent	Capot avant, clair	Cofano anteriore, trasparente
LOS350004	L/R Rear Fender Set, Clear	L/R Heck Schutzblechset, Transparent	Ensemble protections arrières D/G, clair	Serie parafanghi posteriori sinistro/destro, trasparenti
SPM6730	Spektrum Tx Storage Bag	Spektrum Tx Aufbewahrungstasche	Sac d'entreposage Spektrum Tx	Borsa stoccaggio Spektrum Tx
SPM6740	Optional Speedometer DX2E	Optional Tachometer DX2E	Compteur de vitesse facultatif DX2E	Tachimetro opzionale DX2E
SPM6741	Optional Bluetooth Module DX2E	Optional Bluetooth-Modul DX2E	Module Bluetooth facultatif DX2E	Modulo Bluetooth opzionale DX2E
SPM6742	TM1500 Telemetry Module	TM1500 Telemetriemodul	Module de télémétrie TM1500	Modulo telemetria TM1500
SPM6743	Spektrum DX2E Active Speedo Bundle	Spektrum DX2E Active Tachometer-Bündel	Lot de tableaux de bord Speedo DX2E Active	Bundle tachimetro Spektrum DX2E Active
SPM6744	Spektrum DX2E Active Dashboard Bundle	Spektrum DX2E Active Armatur-Bündel	Lot de tableaux de bord Spektrum DX2E Active	Bundle cruscotto Spektrum DX2E Active
SPM6745	DX2E Active Phone Mount	DX2E Active Telefonhalterung	Support de téléphone DX2E Active	Supporto telefono DX2E Active

EXPLODED VIEW EXPLOSIONSZEICHNUNG VUE ÉCLATÉE DES PIÈCES VISTA ESPLOSA DELLE PARTI

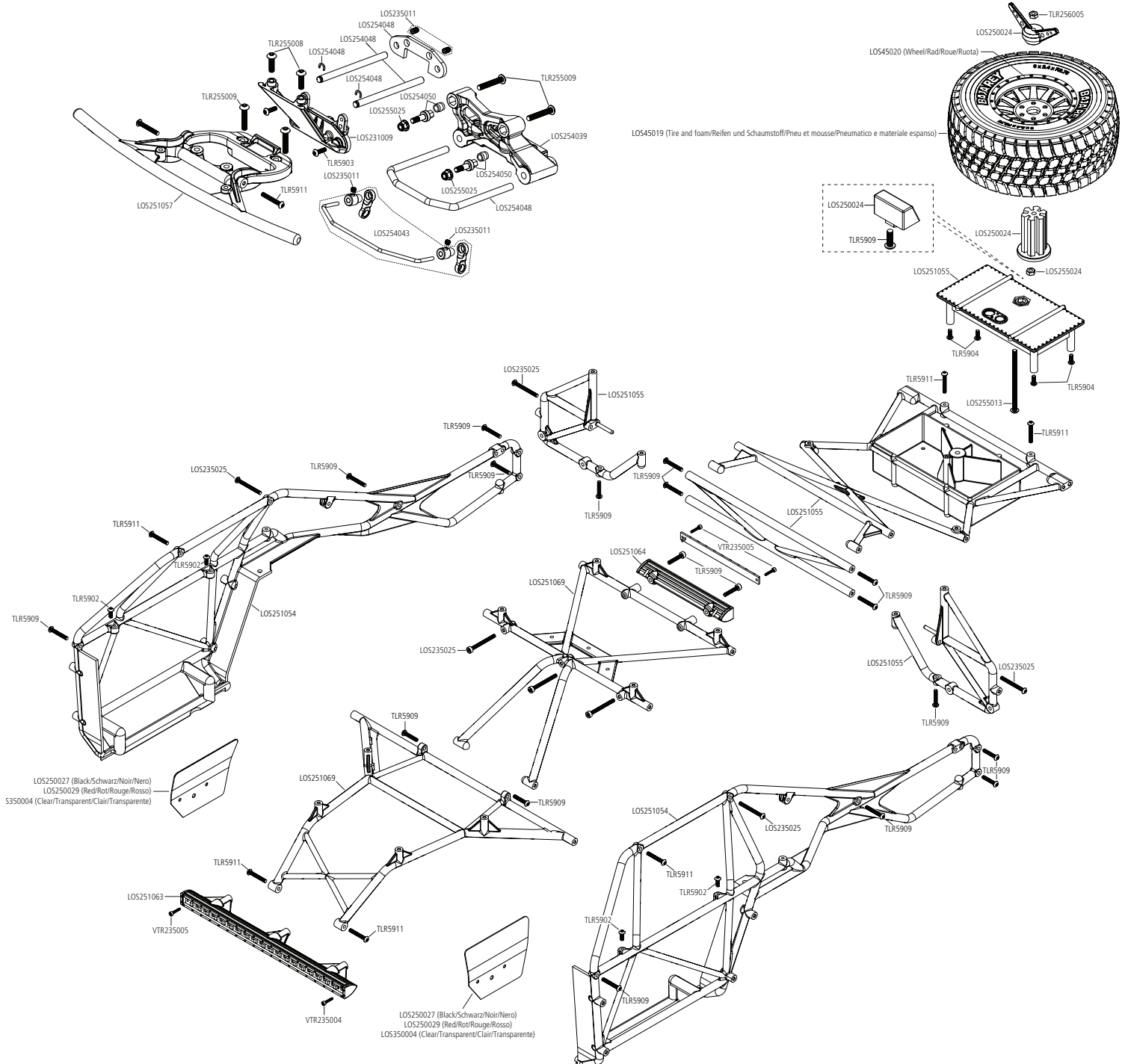

**CHASSIS EXPLODED VIEW
CHASSIS EXPLOSIONSZEICHNUNG
VUE ÉCLATÉE DU CHÂSSIS
VISTA ESPLOSA DEL TELAIO**

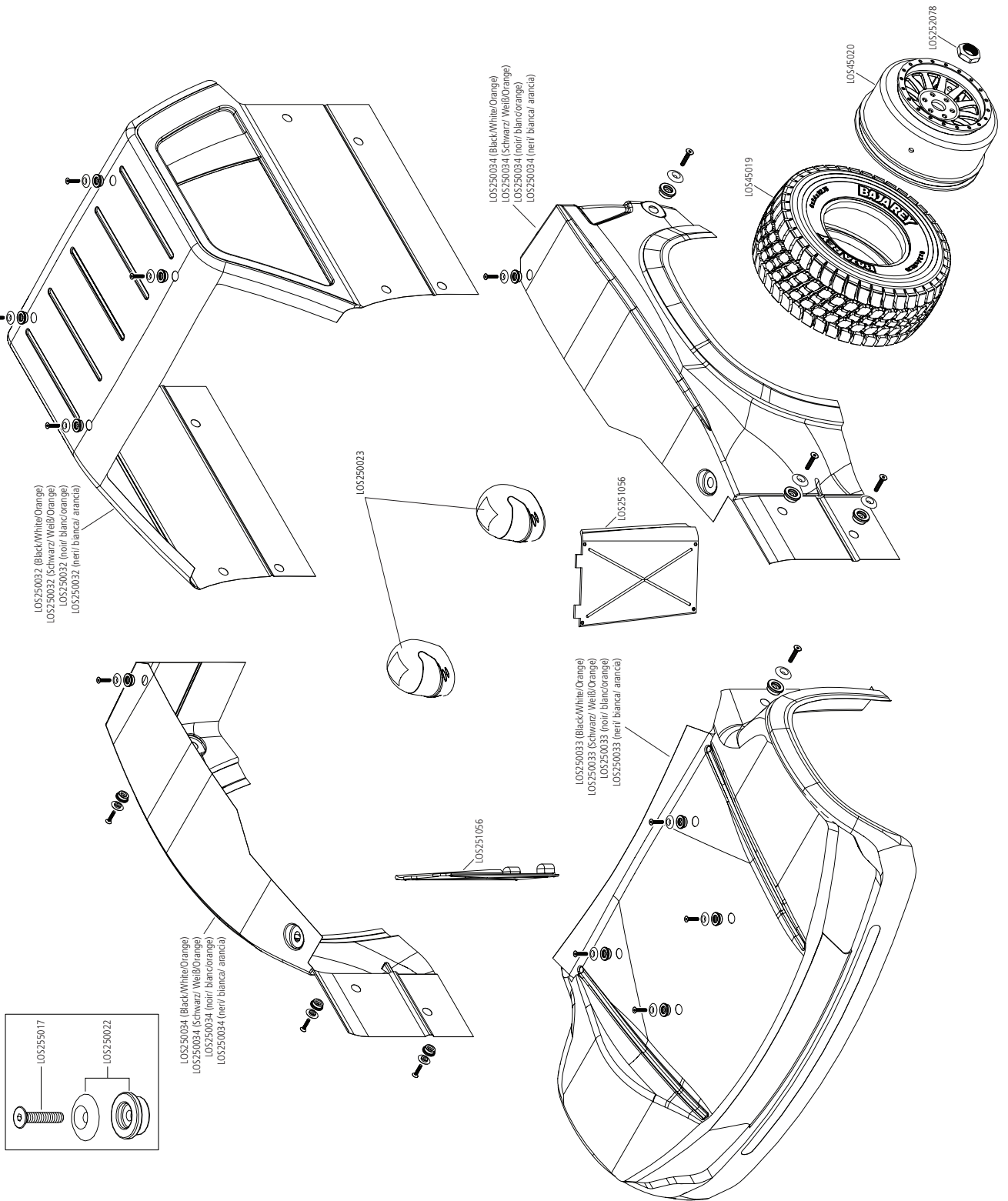

Front Shock

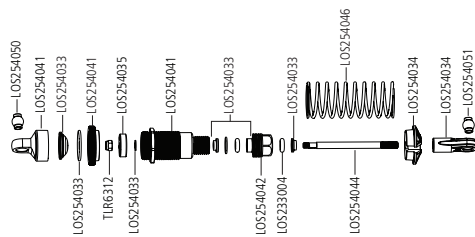

Rear Shock

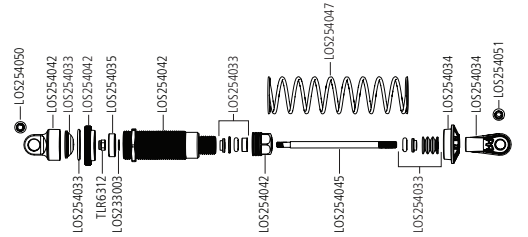

EXPLODED VIEW
EXPLOSIONSZEICHNUNG
VUE ÉCLATÉE DES PIÈCES
VISTA ESPLOSA DELLE PARTI



CHASSIS EXPLODED VIEW
CHASSIS EXPLOSIONSZEICHNUNG
VUE ÉCLATÉE DU CHÂSSIS
VISTA ESPLOSA DEL TELAIO





WWW.LOSI.COM

©2018 Horizon Hobby, LLC.

Losi, Baja Rey, DSM, DSM2, DSMR, AVC, Active Vehicle Control, EC3, Dynamite, Fuze, Prophet and the Horizon Hobby logo are trademarks or registered trademarks of Horizon Hobby, LLC. The Spektrum trademark is used with permission of Bachmann Industries, Inc. Magnaflo, K&N, Kicker, Fox, Lucas Oil, and their respective logos are used under license by Horizon Hobby, LLC. All other trademarks, service marks and logos are property of their respective owners. US 9,320,977. Other patents pending.

Created 08/18

58681 | LOS05018