



NOTICE

All instructions, warranties and other collateral documents are subject to change at the sold discretion of Horizon Hobby, Inc. For up-to-date product literature, visit <http://WWW.LOSI.COM/SUPPORT>

Meaning of Special Language

The following terms are used throughout the product literature to indicate various levels of potential harm when operating this product:

NOTICE: Procedures, which if not properly followed, create a possibility of physical property damage AND a little or no possibility of injury.

WARNING: Procedures, which if not properly followed, create the probability of property damage, collateral damage, and serious injury OR create a high probability of superficial injury.

 **WARNING:** Read the ENTIRE instruction manual to become familiar with the features of the product before operating. Failure to operate the product correctly can result in damage to the product, personal property and cause serious injury.

This is a sophisticated hobby product and NOT a toy. It must be operated with caution and common sense and requires some basic mechanical ability. Failure to operate this Product in a safe and responsible manner could result in injury or damage to the product or other property. This product is not intended for use by children without direct adult supervision. Do not attempt disassembly, use with incompatible components or augment product in any way without the approval of Horizon Hobby, Inc. This manual contains instructions for safety, operation and maintenance. It is essential to read and follow all the instructions and warnings in the manual, prior to assembly, setup or use, in order to operate correctly and avoid damage or serious injury.

Safety Precautions and Warnings

Read and follow all instructions and safety precautions before use. Improper use can result in fire, serious injury and damage to property.

Components

Some electronic components can become hot while in use. Do not touch parts until cool. Use only with compatible components. Should any compatibility questions exist please refer to the product instructions, the component instructions or contact Horizon Hobby, Inc.

Batteries

Always follow the manufacturer's instructions when using and disposing of any batteries. Mishandling of Li-Po batteries can result in fire causing serious injury and damage.

Small Parts

This kit includes small parts and should not be left unattended near children as choking and serious injury could result.

Safe Operating Recommendations

- Inspect your model before every run to make certain it is track worthy.
- Be aware of any other radio frequency user who may present an interference problem
- Always be courteous and respectful of other users of your selected driving area.
- Choose an area clear of and large enough to safely accommodate your driving activity.
- Make certain this area is clear of friends and spectators prior to running your vehicle.
- Be aware of other activities in the vicinity of your path that could cause potential conflict.

IMPORTANT SAFETY NOTES:

- Select an area for assembly that is away from the reach of small children. *Some parts in this vehicle are small and can be swallowed by children, causing choking and possible internal injury; PLEASE USE CAUTION!*
- The shock fluid and greases supplied should be kept out of children's reach. *They are not intended for human consumption!*
- Exercise care when using any hand tools, sharp instruments, or power tools during construction.
- Carefully read all manufacturer's warnings and cautions for *any chemicals, glues, or paints that may be used for assembly and operating purposes.*

□ STEP A-01

Mini Servo Install

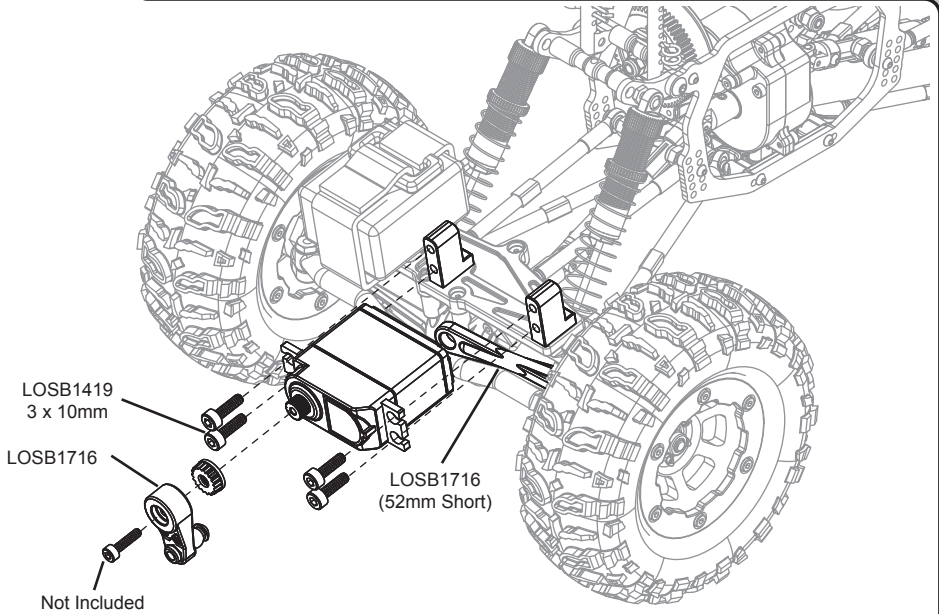

□ STEP A-02

Receiver/ESC Install

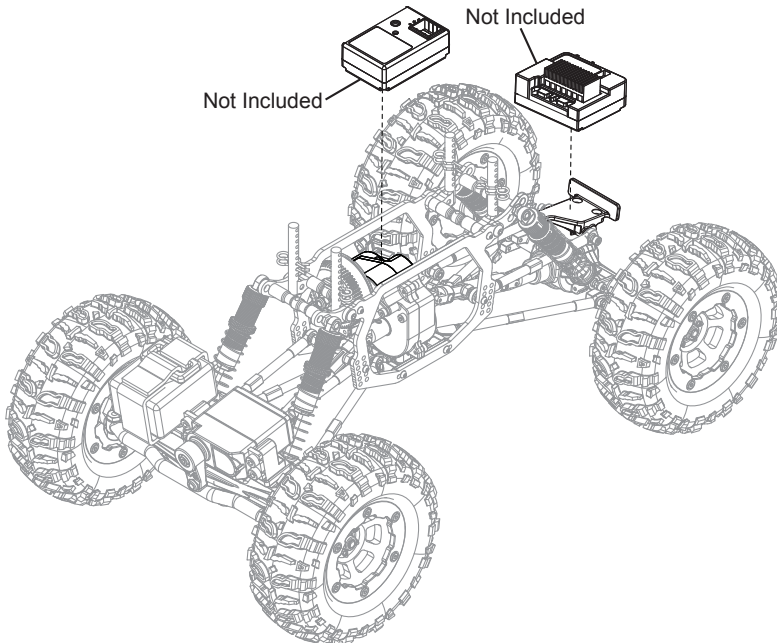

STEP A-03

Motor Install

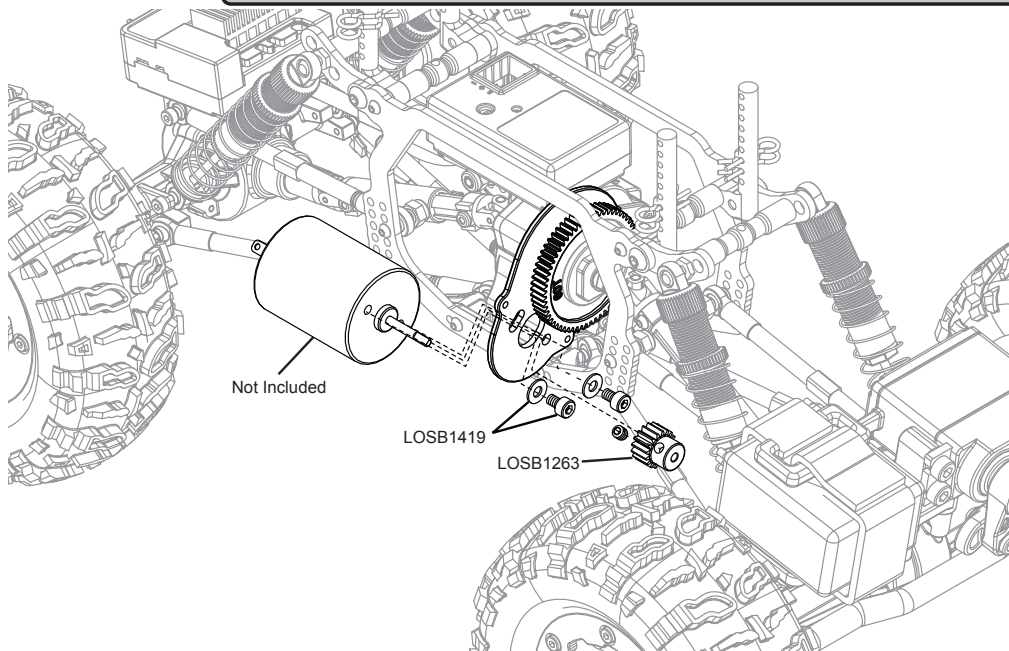

STEP A-04

Optional 1/10th Servo Install

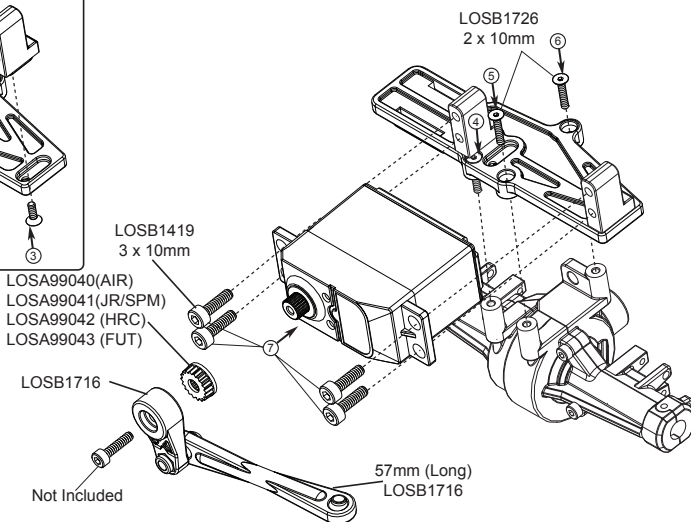
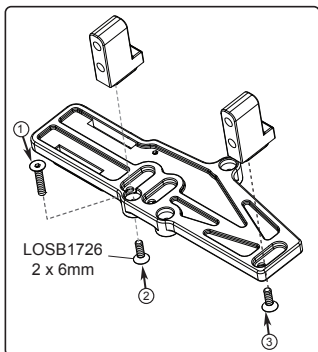

Upper track Rods

Front: In the stock position (5/Out) the front upper track rods are in “neutral” position allowing the shocks to control the movement of the axle. Raising the track rods will stiffen the front causing less chassis roll. Lowering the track rods will cause more chassis roll and allow the front axle to react to obstacles easier. Raising the front track rods will increase the front traction, but make it more difficult for the suspension to react to obstacles.

Rear: In the stock position (5/Out) the rear upper track rods are in a “neutral” position. Raising the rear track rods will make the rear more stable, but less reactive to obstacles. Lowering the rear track rods will create more traction, but will also allow more “sway” and make the rear feel less stable. In testing we have found that lowering the rear track rods will increase rear bite. However, on some vertical climbs, too much rear bite can cause the front end to lift and lose traction.

Shocks

The Mini Rock Crawler Pro has 3 upper shock mounting positions. The kit is set with the shocks in the middle (2) position. Running the shocks in the outer-most position (3) will increase spring rate and chassis body roll. Mounting the shocks in the inner-most position (1) will decrease spring rate and allow the suspension to react more slowly to obstacles.

Shock Arm Position:

Raised Shock Arm: Raising the shock arms (A) will lower the chassis and center of gravity, making the crawler more stable for smooth climbs, descents, and side-hills. This position works best for areas with smooth rocks and steep vertical climbs (slickrock, granite, etc.)

Lowered Shock Arm: Lowering the shock arms (B) will raise the chassis and provide more ground clearance. This position works best for areas with loose or jagged rocks (river beds, volcanic rocks, etc.).

Motor/Battery Combo Suggestions:

The Mini Rock Crawler Pro is designed to use the stock Mini-Rock Crawler ESC (LOSB0828) and motor (LOSB0839). For more power and torque, we suggest using the Xcelorin™ 1/18th Sensored ESC/Motor Combo (LOSB9567) with a 2S LiPo battery (LOSB9831).

Team Tips**Wheel Weights:**

By installing LOSA99201 “Self-stick Chassis Weights” inside the wheels, on the internal wheel ring, overall traction can be improved. Our Team drivers have found that adding 3 ounces to each front wheel and 1.5 to each rear wheel is a great start. Depending on your terrain you may want to increase or decrease the weight.

Shock Tuning:

The kit setup includes 30-weightoil with 5mm limiters inside the shocks. Our Team Drivers found that running stiffer oil and more pre-load on the right rear shock helps further dampen the effects of “torque twist”. In addition, use of the LOSB1446 Outboard Shock Spacer Kit is highly recommended to increase side hilling stability.

They have also found that running a softer spring and lighter oil in both front shocks allows the front to react to obstacles easier and flow over the rocks with greater control.

Weight Bias:

By flipping the transmission and skid plate 180° you are able to shift the weight of the motor slightly forward, increasing the forward weight bias. This is very helpful in areas with break-overs or steep vertical climbs. You will have to reverse the rotation of the motor with this modification.

Suspension Geometry:

The Mini Rock Crawler Pro suspension geometry is designed to minimize axle steer and the effects of torque twist. However, these effects can never be completely eliminated. Through extensive testing, our Team Drivers have determined that using more preload, firmer springs, and stiffer oil in the rear shocks can help dampen the effects of torque twist. Lowering the rear track rods creates more anti-squat which can counteract torque twist in some situations.

FOR MORE SETUP AND TEAM TIPS GO TO WWW.LOSI.COM

Name: _____	Date: _____
City: _____	Event: _____
State: _____	
Comp: _____	
Terrain <input type="checkbox"/> Slickrock <input type="checkbox"/> Granite <input type="checkbox"/> Sandy <input type="checkbox"/> Wet <input type="checkbox"/> Snow Conditions <input type="checkbox"/> Volcanic <input type="checkbox"/> River Rock <input type="checkbox"/> "Red Rock" <input type="checkbox"/> Dusty <input type="checkbox"/> Other _____	

Front Suspension

Upper Track Rod: _____

Shock Arm Position: _____

Shock Mount Position: _____

Shock Oil: _____

Piston: _____

Inner Limiters: _____

Outer Limiters: _____

Spring: _____

Skid Plate Height: _____

Notes: _____

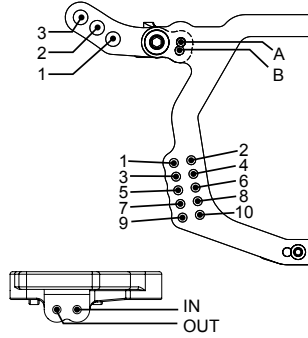

Rear Suspension

Upper Track Rod: _____

Shock Arm Position: _____

Shock Mount Position: _____

Shock Oil: _____

Piston: _____

Inner Limiters: _____

Outer Limiters: _____

Spring: _____

Skid Plate Height: _____

Notes: _____

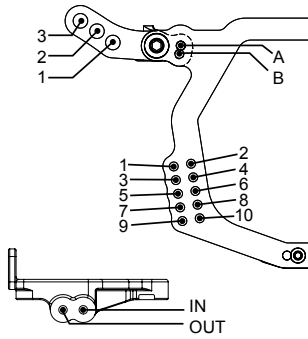

Tires:	Type	Compound	Insert	Weight	Pinion: _____
Front:	_____	_____	_____	_____	Motor: _____
Rear:	_____	_____	_____	_____	Battery Detail: _____
Notes:	_____				

Warranty and Repair Policy**Warranty Period:**

Exclusive Warranty- Horizon Hobby, Inc., (Horizon) warrants that the Products purchased (the "Product") will be free from defects in materials and workmanship at the date of purchase by the Purchaser.

Limited Warranty

Horizon reserves the right to change or modify this warranty without notice and disclaims all other warranties, express or implied.

(a) This warranty is limited to the original Purchaser ("Purchaser") and is not transferable. REPAIR OR REPLACEMENT AS PROVIDED UNDER THIS WARRANTY IS THE EXCLUSIVE REMEDY OF THE PURCHASER. This warranty covers only those Products purchased from an authorized Horizon dealer. Third party transactions are not covered by this warranty. Proof of purchase is required for all warranty claims.

(b) Limitations- HORIZON MAKES NO WARRANTY OR REPRESENTATION, EXPRESS OR IMPLIED, ABOUT NON-INFRINGEMENT, MERCHANTABILITY OR FITNESS FOR A PARTICULAR PURPOSE OF THE PRODUCT. THE PURCHASER ACKNOWLEDGES THAT THEY ALONE HAVE DETERMINED THAT THE PRODUCT WILL SUITABLY MEET THE REQUIREMENTS OF THE PURCHASER'S INTENDED USE.

(c) Purchaser Remedy- Horizon's sole obligation hereunder shall be that Horizon will, at its option, (i) repair or (ii) replace, any Product determined by Horizon to be defective. In the event of a defect, these are the Purchaser's exclusive remedies. Horizon reserves the right to inspect any and all equipment involved in a warranty claim. Repair or replacement decisions are at the sole discretion of Horizon. This warranty does not cover cosmetic damage or damage due to acts of God, accident, misuse, abuse, negligence, commercial use, or modification of or to any part of the Product. This warranty does not cover damage due to improper installation, operation, maintenance, or attempted repair by anyone other than Horizon. Return of any Product by Purchaser must be approved in writing by Horizon before shipment.

Damage Limits

HORIZON SHALL NOT BE LIABLE FOR SPECIAL, INDIRECT OR CONSEQUENTIAL DAMAGES, LOSS OF PROFITS OR PRODUCTION OR COMMERCIAL LOSS IN ANY WAY CONNECTED WITH THE PRODUCT, WHETHER SUCH CLAIM IS BASED IN CONTRACT, WARRANTY, NEGLIGENCE, OR STRICT LIABILITY. Further, in no event shall the liability of Horizon exceed the individual price of the Product on which liability is asserted. As Horizon has no control over use, setup, final assembly, modification or misuse, no liability shall be assumed nor accepted for any resulting damage or injury. By the act of use, setup or assembly, the user accepts all resulting liability.

If you as the Purchaser or user are not prepared to accept the liability associated with the use of this Product, you are advised to return this Product immediately in new and unused condition to the place of purchase.

Law: These Terms are governed by Illinois law (without regard to conflict of law principals).

WARRANTY SERVICES**Questions, Assistance, and Repairs**

Your local hobby store and/or place of purchase cannot provide warranty support or repair. Once assembly, setup or use of the Product has been started, you must contact Horizon directly. This will enable Horizon to better answer your questions and service you in the event that you may need any assistance. For questions or assistance, please direct your email to feedback@teamlosi.com, or call 888.899.LOSI (5674) toll free to speak to a Product Support representative. You may also find information on our website at www.horizonhobby.com.

Inspection or Repairs

If this Product needs to be inspected or repaired, please use the Horizon Online Repair Request submission process found on our website or call Horizon to obtain a Return Merchandise Authorization (RMA) number. Pack the Product securely using a shipping carton. Please note that original boxes may be included, but are not designed to withstand the rigors of shipping without additional protection. Ship via a carrier that provides tracking and insurance for lost or damaged parcels, as Horizon is not responsible for merchandise until it arrives and is accepted at our facility. An Online Repair Request is available at www.horizonhobby.com <http://www.horizonhobby.com> under the Repairs tab. If you do not have internet access, please contact Horizon Product Support to obtain a RMA number along with instructions for submitting your product for repair. When calling Horizon, you will be asked to provide your complete name, street address, email address and phone number where you can be reached during business hours. When sending product into Horizon, please include your RMA number, a list of the included items, and a brief summary of the problem. A copy of your original sales receipt must be included for warranty consideration. Be sure your name, address, and RMA number are clearly written on the outside of the shipping carton.

Notice: Do not ship batteries to Horizon. If you have any issue with a battery, please contact the appropriate Horizon Product Support office.

Warranty Inspection and Repairs

To receive warranty service, you must include your original sales receipt verifying the proof-of-purchase date. Provided warranty conditions have been met, your Product will be repaired or replaced free of charge. Repair or replacement decisions are at the sole discretion of Horizon.

Non-Warranty Repairs

Should your repair not be covered by warranty the repair will be completed and payment will be required without notification or estimate of the expense unless the expense exceeds 50% of the retail purchase cost. By submitting the item for repair you are agreeing to payment of the repair without notification. Repair estimates are available upon request. You must include this request with your repair. Non-warranty repair estimates will be billed a minimum of ½ hour of labor. In addition you will be billed for return freight. Horizon accepts money orders and cashiers checks, as well as Visa, MasterCard, American Express, and Discover cards. By submitting any item to Horizon for inspection or repair, you are agreeing to Horizon's Terms and Conditions found on our website under the Repairs tab.

Country of Purchase	Horizon Hobby	Address	Phone Number/Email
United States	Horizon Service Center (Electronics and engines)	4105 Fieldstone Rd, Champaign, IL 61822 USA	877-504-0233 productsupport@horizonhobby.com
	Horizon Product Support (All other products)	4105 Fieldstone Rd, Champaign, IL 61822 USA	877-504-0233 productsupport@horizonhobby.com
United Kingdom	Horizon Hobby Limited	Units 1-4 Ployters Rd. Staple Tye Harlow, Essex CM18 7NS United Kingdom	+44 (0) 1279 641 097 sales@horizonhobby.co.uk
Germany	Horizon Technischer Service	Hamburger Str. 10 25335 Elmshorn Germany	+49 4 121 46199 66 service@horizonhobby.de
France	Horizon Hobby SAS	14 Rue Gustave Eiffel Zone d'Activité du Révell Matin 91230 Montegeron	+33 (0) 1 60 47 44 70

INSTRUCTION FOR DISPOSAL OF WEEE BY USERS IN THE EUROPEAN UNION



This product must not be disposed of with other waste. Instead, it is the user's responsibility to dispose of their waste equipment by handing it over to a designated collection point for the recycling of waste electrical and electronic equipment. The separate collection and recycling of your waste equipment at the time of disposal will help to conserve natural resources and ensure that it is recycled in a manner that protects human health and the environment.

For more information about where you can drop off your waste equipment for recycling, please contact your local city office, your household waste disposal service or where you purchased the product.